



10641 Highway 36  
Covington, GA  
30014

[www.sunbeltbuilders.com](http://www.sunbeltbuilders.com)

t 770.786.3031  
f 770.786.3046

## Senior Services Enrichment Center

Alliance Commercial Window Treatment  
100 Petty Road  
Suite A-1  
Lawrenceville, GA 30043  
ph: 770-277-0858  
David Seckinger  
[daves@acwtinc.com](mailto:daves@acwtinc.com)

12-2400 Shades O&M

# True Performance Single Shades

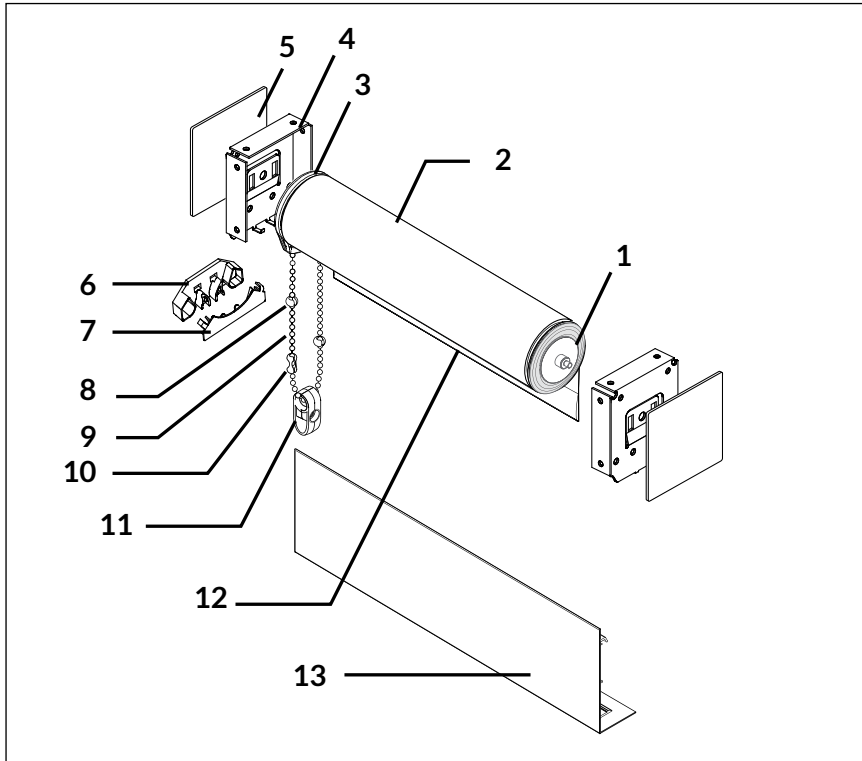

## Single Fascia Manual Shade

1. Idle End Plug
2. Shade
3. Clutch
4. Fascia Bracket (3" fascia bracket shown)
5. Fascia Bracket Cover
6. 3" Fascia Chain Diverter
7. 3" Chain Diverter Cover (SL10 & SL15 clutches only)
8. Stop Bead (attached in field)
9. Stainless Steel Bead Chain
10. Chain Connector
11. Chain Guide
12. Heat-Sealed Hem Pocket
13. 3" or 4" Fascia

**NO FASCIA BRACKET**

**FASCIA BRACKET**

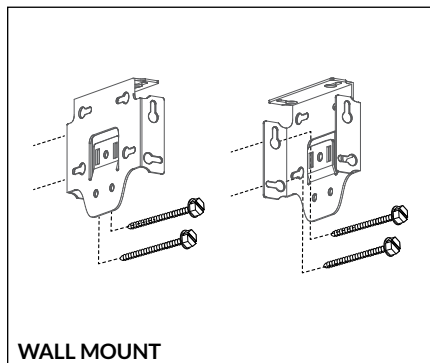
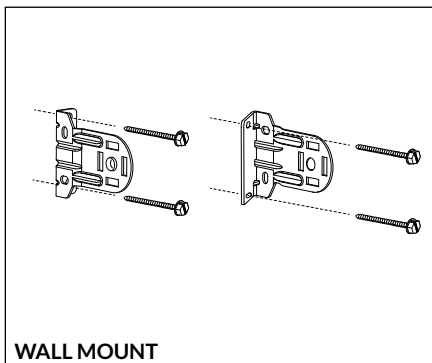
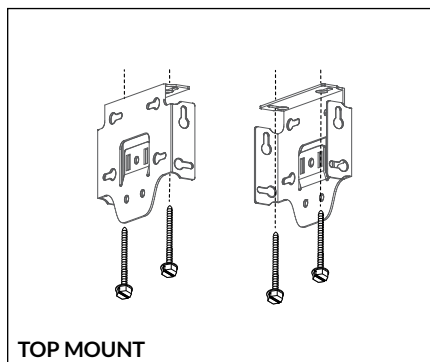
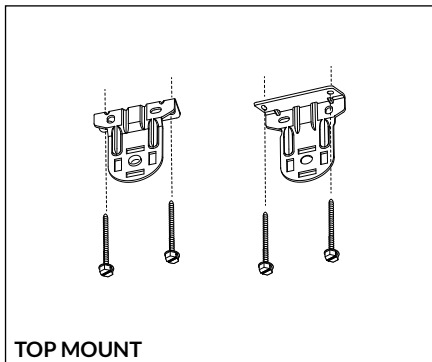
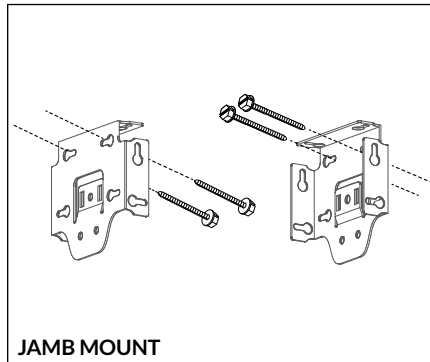
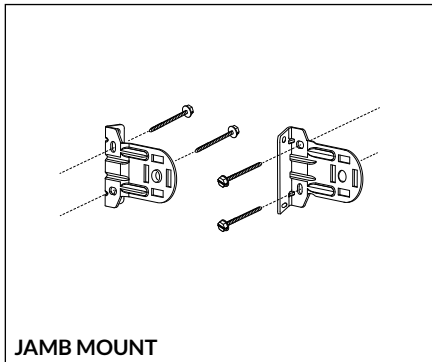

**Install Brackets**

1. Use a minimum of 2 fasteners suitable for the mounting surface per bracket.
2. Mount control and idle brackets.

**NOTE:**

Make sure that the screw heads clear the clutch or motor.

The open end of each bracket faces downward, as shown in the drawing.

Heavier shades may require more fasteners.

## 4" FASCIA SHADE INSTALLATION

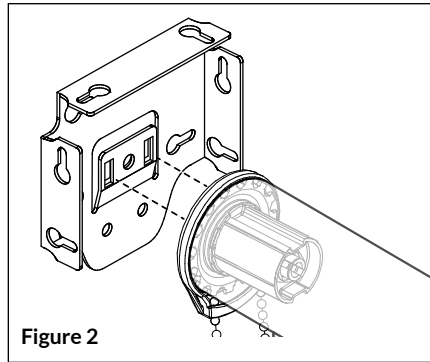
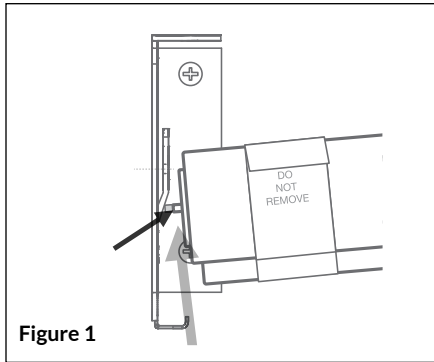

1. Place the idle end pin into the center hole in the idle bracket. (Figure 1)
2. Compress the idle end spring and align and hook the clutch or motor into the drive end bracket. (Figure 2)
3. Check that idle pin and clutch hooks are fully seated in each bracket. (Figures 3a and 3b)
4. Remove paper bands by hand. Do not cut off paper bands. (Figure 4)

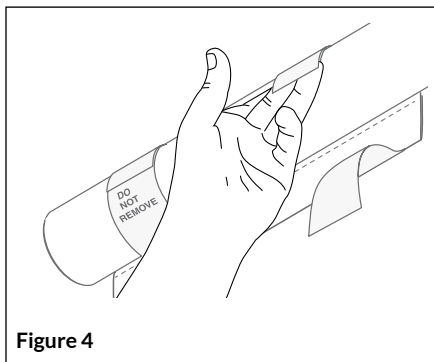
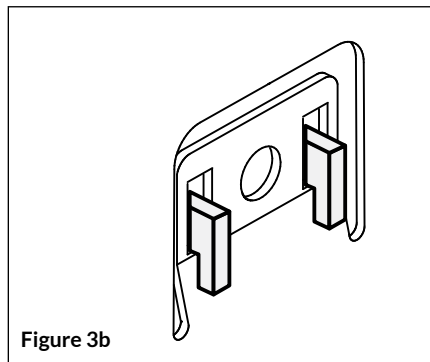
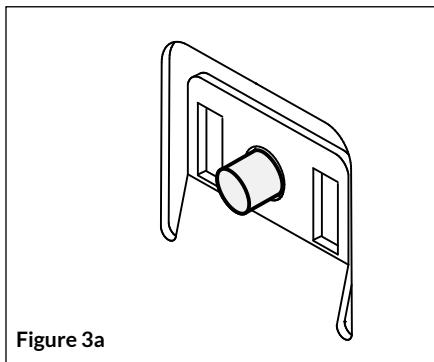

### 4" FASCIA CLIP INSTALLATION

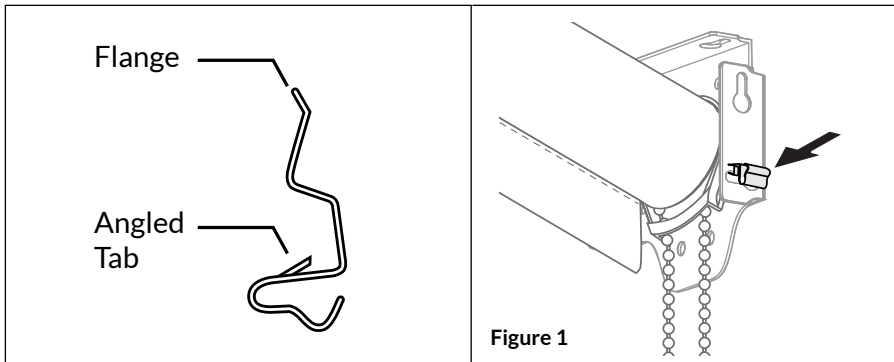

1. Insert the 4" fascia clip through the bottom slot on the face of the bracket. (Figure 1)
2. Press firmly on the clip until the bracket is seated behind the angled tab. (Figure 2)

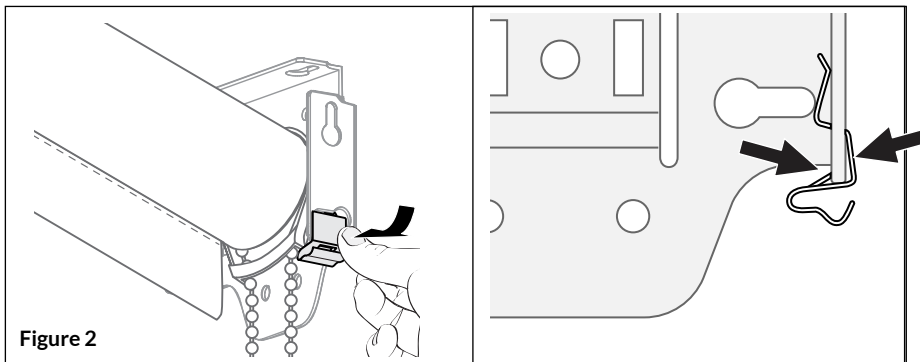

### 3" AND 4" FASCIA INSTALLATION

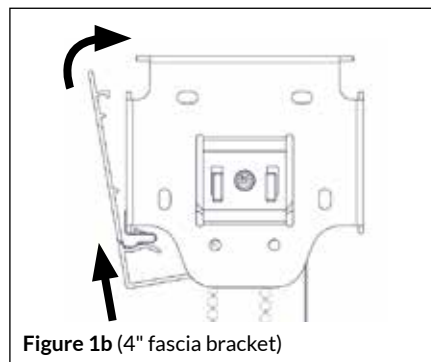
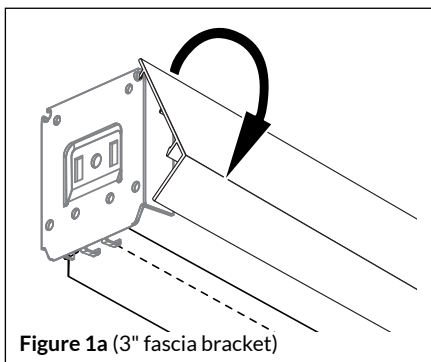

1. For 3" fascia, hook the fascia to the top of the bracket and gently press at the bottom until the fascia fully snaps onto the bracket. (Figure 1)
2. For 4" fascia, place the fascia trough onto the bottom of the spring clip, push upward to compress the spring clip and snap the top of the fascia over the bracket (Figure 1b)
3. Attach fascia bracket cover. Prepare bracket by cleaning debris and dust. Remove adhesive backing from bracket cover and attach to bracket. (Figures 2a and 2b)

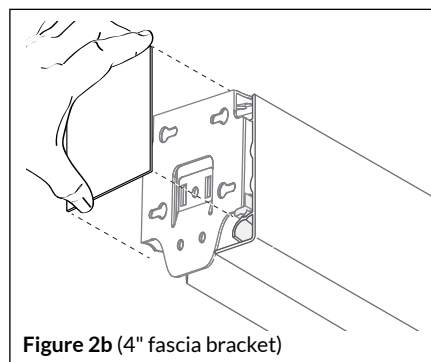
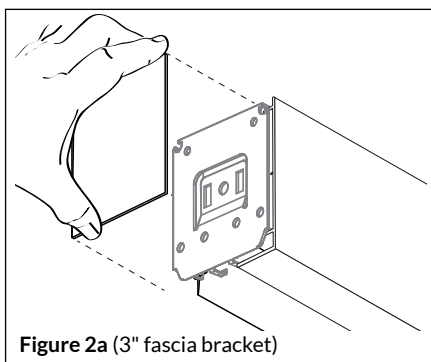

## CHAIN GUIDE INSTALLATION

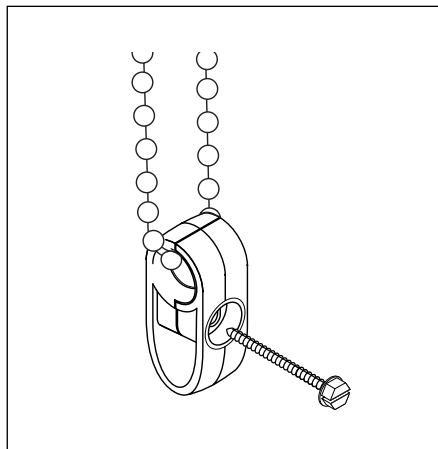

**IMPORTANT:** Chain guide must be installed for proper shade operation.

1. Unwrap control chain loop and determine a mounting location for the guide on the wall or jamb.
2. With the control chain loop under minimal tension, compress the guide and install screw.

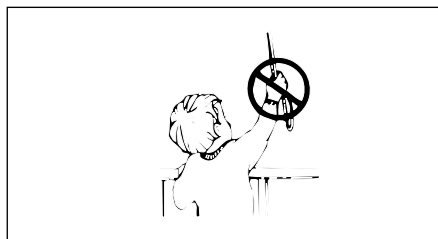

**WARNING:**

The chain guide reduces the hazards of strangulation and entanglement of young children by limiting access to the control chain.

## SET UPPER/LOWER LIMITS

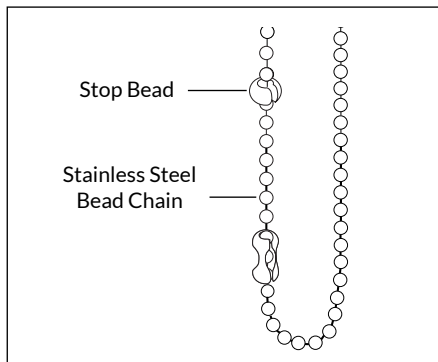

1. Roll shade to lower limit position.
2. Attach stop bead next to the clutch on the front of the chain of a regular roll shade or the back of the chain of a reverse roll shade.
3. Raise the shade to its upper limit position, and attach the stop bead next to the clutch on the back of the chain of a regular roll shade or the front of the chain of a reverse roll shade.

## OPERATION

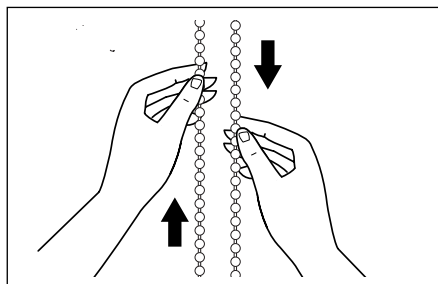

**Right Hand Side Clutch**

Pull chain in front to raise shade; pull chain in back to lower shade. The opposite is true for reverse roll shades.

**Left Hand Side Clutch**

Pull chain in back to raise shade; pull chain in front to lower shade. The opposite is true for reverse roll shades.

# Shade Cloth Cleaning and Disinfecting Guidelines



## 1 Dust

Using an electrostatic duster with a soft, disposable head or the brush attachment of a vacuum.

## 2 Clean

Using mild soap and water, clean gently with a sponge or soft cloth.

## 3 Dry

Using a clean, soft cloth or duster.

## 4 Disinfect

Using a product that has Hydrogen Peroxide as the active ingredient. Be sure to follow the instructions on the product's label to ensure effective use of the product.

Hydrogen Peroxide meets the EPA's criteria for use against SARS-CoV-2, the virus that causes COVID-19.

For alternate, approved shade cloth disinfecting options, refer to the [Shade Cloth Disinfecting Information](#) sheet.

*NOTE: Using non-approved or abrasive cleaning agents or methods, may result in damage to the shade. Damage caused by the use of non-approved cleaning agents or methods not listed in this document are not covered under the SWFcontract warranty. Please contact your customer service team member with any questions.*

### Cleaning and Disinfecting Tips

- Wear gloves and make sure there is good ventilation during disinfecting
- Follow the contact time for disinfecting to ensure the product is effective
- Dust, clean, and dry in a single direction
- Avoid steam cleaning as it may melt the PVC or distort the stability of the shade
- Avoid cleaning in bright, hot sunlight to prevent soap spotting

## Antibacterial and Antifungal Shade Cloth

Antibacterials and antifungals inhibit or slow the spread of microorganisms like bacteria and fungi such as mold and mildew.

Our shade cloths contain low amounts of added antimicrobials. The antimicrobial chemicals are encapsulated within the PVC yarn jacket, to reduce the risk of leaching.

### ASTM E2180

The method focuses primarily on assessing antibacterial activity.

#### Passing Shade Cloth:

Aspect

Compass

Conceal

Crosshatch R & S

Double-Take

Factor

Latitude

Parallel

Summit

Zenith

### ASTM G21

This practice covers determination of the effect of fungi on the properties of materials such as shade cloth.

#### Passing Shade Cloth:

Aspect

Compass

Conceal

Crosshatch A, R & S

Double-Take

Factor

Latitude

Parallel

Summit

Zenith

# WARRANTY INFORMATION

## SPRINGS WINDOW FASHIONS LIMITED WARRANTY

### WHAT IS COVERED

The product is warranted against defects in materials or workmanship for the time period specified below, provided that the product was properly installed, the product was made or assembled exclusively from Springs Window Fashions' materials and components, and all Springs Window Fashions' recommendations were followed with regard to limitations and specifications. This warranty extends only to you as the original purchaser of the product.

### LIMITED LIFETIME WARRANTY

- Cellular shades
- Roller shades
- Solar shades
- Roman shades
- Natural shades
- Pleated shades (with looped tape)
- Sheer shades
- Layered shades
- Wood blinds
- Faux wood blinds
- Composite blinds
- Wood shutters
- Composite shutters
- Sliding panels
- 1" and 2" aluminum horizontal blinds
- 2" vinyl horizontal blind headrails and components
- Vertical blind headrails, channel panels, and sheer fabric
- Painted and stained valences
- Painted and stained cornice
- Ladders and cloth tapes

### FIVE-YEAR WARRANTY

- Motorized components and accessories (batteries not included)
- Exterior solar shades
- Draperies
- Fabric covered cornices and valances
- Fabric tailored shades and accessories

### THREE-YEAR WARRANTY

- Operating cords
- Pleated shades (without looped tape)
- 2" vinyl horizontal blind slats
- Vertical blind vanes

### WHAT IS NOT COVERED

- Unfinished cornices, valances, or Palladian shelves
- Normal wear and tear, including:
  - » Loss of color intensity, discoloration, fading, cracking or yellowing caused by long exposure to direct sunlight
  - » Slight color variation
  - » Natural variations in color or grain of wood
  - » Natural variations, cracking, splitting, twisting, bowing, shrinking, or stretching of organic material used in natural shades
  - » Slight warpage of wood blinds or shutters; excessive warpage of wood blinds or shutters caused by moisture or high humidity
  - » Exterior solar shades damage caused by inclement weather, windy conditions, coastal/salt conditions, pressure washing, or exposure to chemicals including chlorine
  - » Shutters damage caused by improper maintenance including sanding, improper washing, and use of razor blades or sealants

» Fabric damage caused by abuse, accidents, alterations, misuse, or failure to follow measuring/installation/use/cleaning maintenance instructions

## WARRANTY OBLIGATIONS

The obligations of Springs Window Fashions are limited to the replacement or repair of parts or products found to be defective. If repairs are made under this warranty, the repairs will be made with like or similar parts. It is at the sole discretion of Springs Window Fashions to determine whether product will be replaced or repaired.

Springs window fashions is not responsible for shipping costs or labor costs, for measuring and taking the product down, or for re-measuring or reinstalling the product.

SWF may defer actions on any claim for warping for a period of up to twelve (12) months from the date of the claim in order to permit acclimating to humidity and temperature conditions.

Warranty coverage applies to defective product only. Other window coverings in the room/household will not be replaced.

## SERVICE

To learn more about warranty claims, contact customer service at 1-800-221-6352 or [windowfashions@springswindowfashions.com](mailto>windowfashions@springswindowfashions.com).

Warranty claims must be accompanied by the original sales receipt as well as details regarding the nature of the problem, location of the product, etc. Warranty claims may be submitted to the Customer Service Center at:

Customer Service Center  
Springs Window Fashions, LLC  
8467 Route 405 Highway South  
PO Box 500  
Montgomery, PA 17752-0500

THIS WARRANTY IS EXCLUSIVE AN IN LIEU OF ALL OTHER WRITTEN OR ORAL WARRANTIES OR OBLIGATIONS AND LIABILITIES. THE DURATION OF ANY IMPLIED WARRANTIES FOR ANY PRODUCT IS LIMITED IN DURATION TO THE WARRANTY TERM APPLICABLE TO SUCH PRODUCT AS SET FORTH ABOVE.

SPRINGS WINDOW FASHIONS SHALL HAVE NO LIABILITY WHATSOEVER FOR INCIDENTAL, PUNITIVE, OR CONSEQUENTIAL DAMAGES.

Some states do not allow the exclusion or limitation of incidental, punitive, or consequential damages, so this limitation or exclusion may not apply to you.

No person is authorized to extend or alter this warranty.