



10641 Highway 36  
Covington, GA  
30014

[www.sunbeltbuilders.com](http://www.sunbeltbuilders.com)

t 770.786.3031  
f 770.786.3046

## Newton County – R.L. Cousins Center

Covington Air Systems  
P.O. Box 1526  
Covington, GA 30015  
ph: 770-385-0068  
Byron Hopper

[bhopper@covingtonairsystems.com](mailto:bhopper@covingtonairsystems.com)

23-0000 HVAC O&M – Phase 2

# C0STAT05FF1L CS3000 Commercial Programmable Thermostat

CONTROLS  
507518-01  
10/2015  
Supersedes 2/2015



## C0STAT05FF1L 5/2 Day Programmable Thermostat

The Lennox ComfortSense® 3000 Series Commercial Programmable Thermostat, Model C0STAT05FF1L (11Y05) is a 5/2 day programmable and 2-heat / 2-cool electronic thermostat. It includes a programmable filter change reminder, an equipment maintenance reminder, and a system check indicator to notify the user when the equipment requires service.

This thermostat is suitable for 2-stage heat / 2-stage cool applications using a gas or electric auxiliary heat source and can also be used with an economizer.

THIS MANUAL MUST BE LEFT WITH THE OWNER  
FOR FUTURE REFERENCE

## **▲** WARNING

Improper installation, adjustment, alteration, service or maintenance can cause property damage, personal injury or loss of life. Installation and service must be performed by a qualified installer, service agency or the gas supplier

The remote indoor sensor when connected and configured will act as a room temperature sensor instead of internal temperature sensor available with the thermostat. The dip switch is used to select either built-in or external remote indoor temperature sensor used for temperature control.

## Table of Contents

5/2 Day Programmable Thermostat .....	1
General .....	2
Initial Thermostat Power-up .....	2
Buttons, Backlight, Timers & Settings .....	3
DAY/TIME - Set Day and Time .....	4
HEAT - Heat Mode .....	4
COOL - Cool Mode .....	5
HOLD - Temperature Hold Mode .....	6
PROG - Thermostat Programming .....	7
FAN - Controlling Fan Operation .....	9
SETTINGS - Filter and Maintenance Reminders .....	10
SETTINGS - Balance Point .....	11
Service Indicator .....	12
Thermostat RESET .....	12
Removing/Installing Thermostat .....	13
Default Thermostat Settings .....	13
Technical Specifications .....	13

## General

These instructions are intended as a general guide and do not supersede local codes in any way. Consult authorities having jurisdiction before installation. Check equipment for shipping damage. If you find any damage, immediately contact the last carrier.

## Initial Thermostat Power-up

When power is initially applied to the thermostat, the display will appear as shown in figure 1.

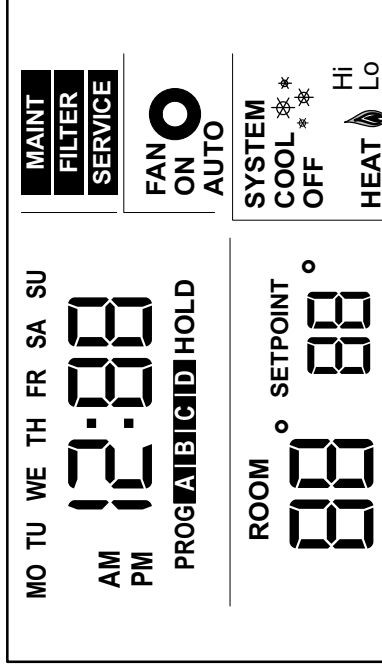

Figure 1. Initial Power-Up Display

NOTE - Tables 3 on page 13 lists all of the system defaults.

At this point, the thermostat will be fully functional; its default temperature set point (not shown) is 70°F. At this point, if the equipment has been fully powered and if a heat demand were present, the system would begin operating. **UC** indicates unoccupied and **OC** indicates occupied.

*NOTE - Temperature scale default is Fahrenheit units but may be reset to show Celsius, if desired. See page 14.*

### Buttons, Backlight, Timers & Settings

Buttons are located behind the small door on the right-hand side of the thermostat (see figure 2).

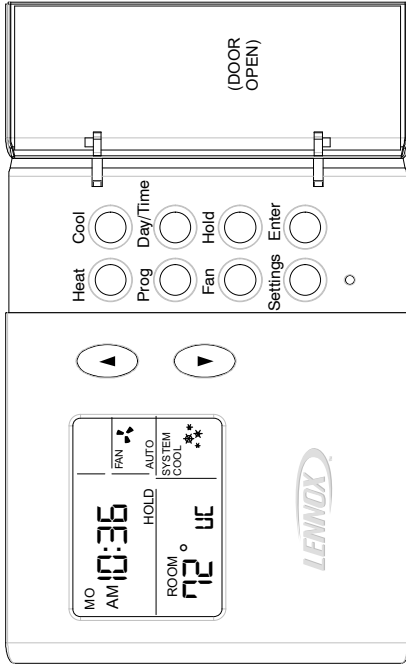

Figure 2. Thermostat Buttons

## IMPORTANT

**Do NOT** begin pressing buttons until after you read the following section describing each button.

A pale blue display backlight illuminates for 30 seconds each time any button is pressed.

When **PROG** or **DAY/TIME** is pressed, a field begins flashing, expecting another input. Start making changes within 15 seconds or the HOME screen will return.

When an **Arrow**, **HOLD**, **HEAT**, or **COOL** button is pressed, setpoint and temperature setting appears for 15 seconds. If desired, start making changes within 15 seconds or the HOME screen will return. The backlight will turn off 15 seconds after the HOME screen reappears.

## DAY/TIME - Setting the Day and Time

Press the **DAY/TIME** button and set the **CURRENT** hour, minute, and day of week as follows:

1. "AM12" will flash on the screen. Press the up or down arrows buttons to change the hour. ("AM" or "PM" must correspond to time of day.) Press **DAY/TIME** OR, if *adjusting for daylight savings time, pressing ENTER stores the single change and exits to the HOME screen, bypassing minutes and day of week.*
2. Minutes will flash. Use the up or down arrow buttons to display the minutes past the hour. Press **DAY/TIME**.
3. Day "MO" (Monday) will flash. Use up or down arrow buttons to display the current day. Day selections are abbreviated as "MO", "TU", "WE", "TH", "FR", "SA", and "SU". Press **DAY/TIME**.
4. The HOME screen reappears; confirm day and time are correct. This completes day and time setting.

## HEAT - Using the Heat Mode

### Enabling Normal Heat Mode

Use the **HEAT** button to enable or disable heat mode. If the thermostat is in OFF or COOL mode, pressing the Heat button enables Heat mode. This is indicated by HEAT in the SYSTEM box as shown in figure 3.

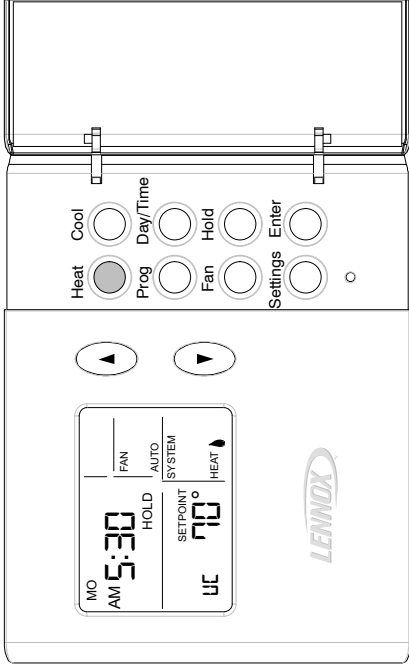

**Figure 3. Turn Heat ON/OFF Disabling Heat Mode**

If the thermostat is in heat mode when the **HEAT** button is pressed, then heat mode is disabled. This is indicated by OFF in the SYSTEM box as shown in figure 4.

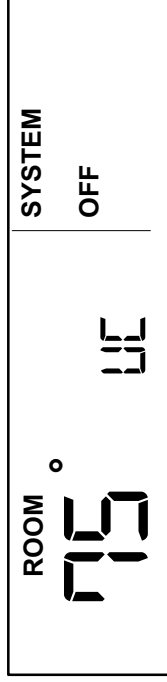

**Figure 4. Heat Mode Disabled**

## Heating Demand

The thermostat must be in heat mode in order to properly control the heating equipment. In heat mode, when the actual temperature is lower than the temperature set point the thermostat detects a heating demand and activates the heating equipment to satisfy the demand. Heating operation is indicated by a flame icon in the SYSTEM box.

When the actual temperature rises above the temperature setpoint, the flame icon will disappear. This indicates that the heating demand has been satisfied and that the heating equipment has been turned off.

There are two timers govern the restart of heating:

1. Minimum furnace off timer (1.5 minutes only for HG).
2. Minimum cycle timer (six minutes).

For example:

If heating has been on for over six minutes then minimum cycle timer is already fulfilled. For HG (gas), it will restart after 1.5 minutes. For HE (electric), it will restart immediately.

If the heating has not been on for six minutes, it will make up the six minutes during the off time. Therefore the lock out time is never six minutes.

## COOL - Using the Cool Mode

### Enabling and Disabling Cool Mode

Use the **COOL** button to enable or disable cool mode as desired. If the thermostat is in **HEAT** or **OFF** mode, cool mode is enabled when the **COOL** button is pressed. This is indicated by **COOL** in the **SYSTEM** box (see figure 5).

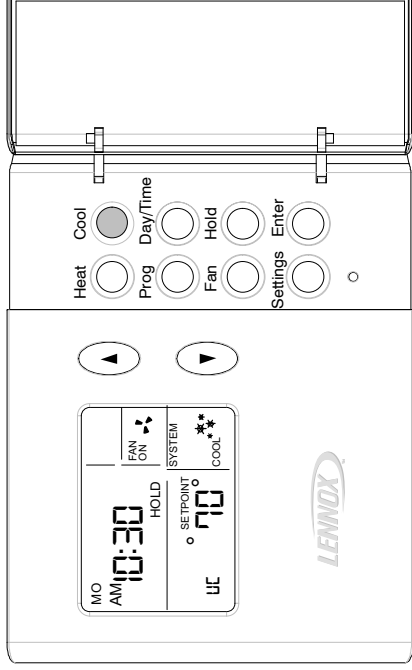
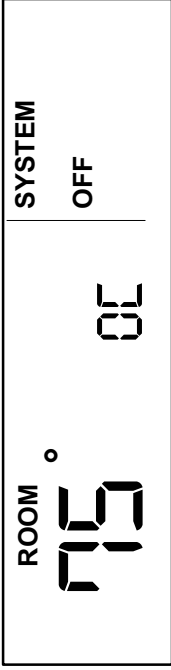

Figure 5. Turn Cool ON/OFF

If the thermostat is in cool mode, pressing the **COOL** button disables COOL mode (indicated by OFF in the SYSTEM box - see figure 6).



**Figure 6. Cool Mode Disabled**

### Cooling Demand

Set the thermostat to cool mode to control the cooling equipment. Then, if the room temperature is higher than the temperature setpoint, the thermostat detects a cooling demand and will activate the cooling equipment to satisfy the demand.

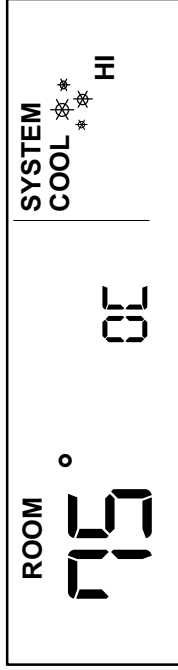

**Figure 7. Cooling Demand**

Cooling operation is indicated by flashing “snowflake” icons in the SYSTEM box. When the actual temperature drops below the temperature setpoint, the snowflake icons will

disappear. This indicates that the cooling demand has been satisfied and that the cooling equipment has been turned off.

If a large cooling demand is present, “HI” will be displayed in the SYSTEM box (shown in figure 7).

*NOTE - If no buttons are pressed during a demand for cooling, the equipment must operate for at least four minutes. After a demand has been satisfied, cooling equipment operation is locked out for five minutes. If another cooling demand occurs during this 5-minute interval, “COOL” and the snowflakes will flash; however, the cooling equipment will not operate until the 5-minute delay has elapsed.*

### **HOLD - Using Temperature Hold Modes**

When HOLD is displayed on the HOME screen, the thermostat is in a temperature hold condition. This means that the temperature program data is ignored and the thermostat functions much like a non-programmable thermostat.

### **Adjusting Temperature Setpoint in Hold Mode**

The temperature setpoint represents the desired temperature of the space around the thermostat.

To adjust the setpoint, press the up or down (▲▼) arrow buttons the existing setpoint is displayed to the right of the

occupancy mode. Each button press adjusts the setpoint up or down by 1 degree.

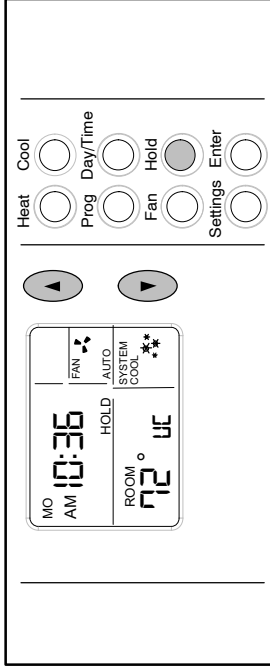

**Figure 8. Hold Temperature Mode**

After the desired setpoint is reached, the HOME screen will reappear after about 15 seconds (see figure 8).

**Permanent Hold Mode**

At any time the program is running, from the HOME screen, set a permanent hold (program override) by pressing the **HOLD** button (see figure 8). The thermostat now functions much like a non-programmable thermostat. Use the Up/Down arrow buttons to adjust the hold set point. To return to the program, press **HOLD** again. The occupancy status will remain unchanged in permanent hold mode.

**Temporary (2-Hour) Hold**

At any time the program is running, from the HOME screen, set a temporary 2-hour hold by pressing the up or down

arrow buttons until the desired set point is displayed; “HOLD” flashes (see figure 9). This overrides the program for 2 hours from the last button press, then returns to the program.

To change occupancy status in temporary hold mode, press the **ENTER** button while **HOLD** indicator flashes. The occupancy can be set to OC (occupied) / UC (unoccupied) by pressing the **ENTER** button.

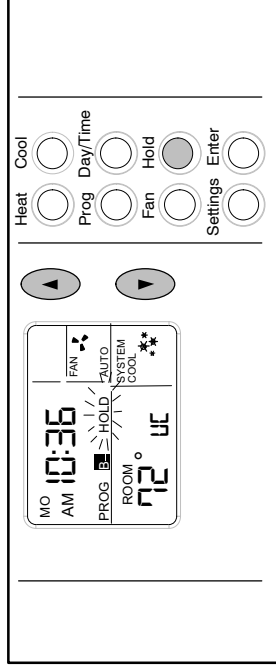

**Figure 9. Temporary Hold Temperature Mode**

While in Temporary Hold, press **HOLD** once to switch to Permanent Hold (**HOLD** displays solid; **PROG** not displayed); press **HOLD** again to return to the program (**PROG** displays; **HOLD** not displayed).

**PROG - Thermostat Programming**

The thermostat can be programmed to perform a set of either heating or cooling events (but not a combination of

heat and cool) for five consecutive days using a set of four unique events per day. The remaining two days can then be set for a different set of four unique events per day. Both the consecutive days and the events/temperature are set by the user.

**To Change Consecutive Days...**

To alter the five consecutive days, **press and hold the PROG** button for three seconds. The five consecutive day period is then displayed (default is MOnday thru FRIday). To change to a different 5-consecutive days, use the up or down arrow buttons. Any five consecutive-day span may be selected, for example, in figure 10, Saturday through Wednesday is defined as the 5-day programming (Thursday and Friday would constitute the 2-day programming). Press the **PROG** button when finished.

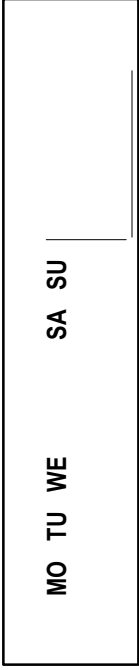

**Figure 10. Change Consecutive days To Set Program Events and Temperatures...**

Figure 11 gives an example of how the two sets of programs can be set for a normal workweek and weekend. In the 5-day bar graph, note how programs **A** and **C** reflect the desired warmth while the location IS occupied (72°); **B**

allows less heating while the location is NOT occupied; **D** reflects a cooler sleeping temperature. The 2-day bar graph would support day-long occupancy and, because the first program begins later, a less-demanding time schedule.

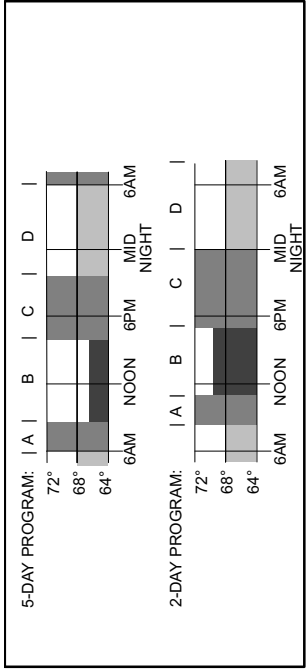

**Figure 11. 5/2 Day Program Example**

**NOTE** - Pressing **ENTER** during the following programming steps, saves and exits to the HOME screen.

To program events and temperatures, perform the following steps, once with Cool selected and once with Heat selected.

1. Press either the **HEAT** or **COOL** button.
2. Press and release **PROG**. "AM 6:00", period "A", and the 5 consecutive days are displayed; "AM 6" flashes.
3. Use the up or down arrow buttons to select the desired hour; press **PROG** when the desired hour is reached.
4. Use the up or down arrow buttons to select the desired minute; press **PROG**.

5. Use the up or down arrow buttons to select either **uc** (unoccupied) or **oc** (occupied) minute; press **PROG**.
6. Use the up or down arrow buttons to select the desired temperature set point; press **PROG**.
7. Repeat steps 3 through 6 for periods B, C, and D.
8. Repeat steps 1 through 7 for the 2-day program.

*NOTE - This thermostat will NOT automatically switch from heating to cooling, or cooling to heating; operator involvement is required. At the change of seasons, or to accommodate abnormal seasonal temperature swings, you must manually select to the opposite conditioning (Heat or Cool) program.*

### **FAN - Controlling the Fan Operation**

Use the **FAN** button to select either continuous fan mode or auto fan mode.

To change from continuous to auto fan mode or back to continuous, press the **FAN** button. Note whether a fan icon in the **FAN** box is present (indicating that the fan is running) or not (fan not running).

If continuous fan mode is enabled (ON displayed in **FAN** box - see figure 12), the fan will run continuously regardless of whether the heating or cooling equipment is running.

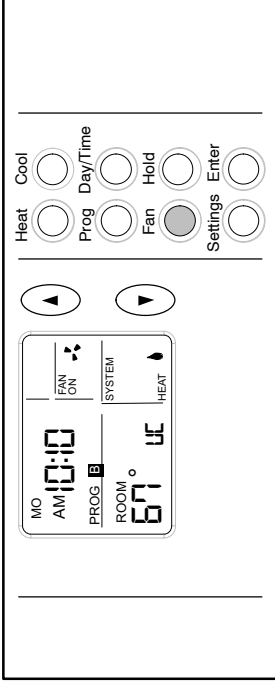

**Figure 12. Using Fan ON**

If auto fan mode is selected (AUTO displayed in **FAN** box - see figure 13), the fan will only run when the heating or cooling equipment is running.

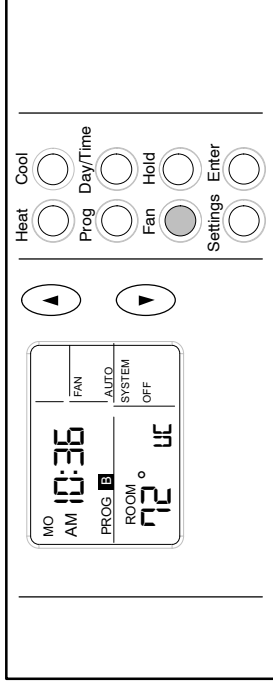

**Figure 13. Using Fan AUTO**

## SETTINGS - Filter/Maintenance Reminders

The thermostat is designed to remind you when the filter needs changing or when routine maintenance is required, as (and if) defined, by you. These optional reminders are not enabled until you activate them. To do so, press the **SETTINGS** button (shown below the Fan button in figure 13) once or twice for the desired reminder as shown in figure 14 and as described in table 1.

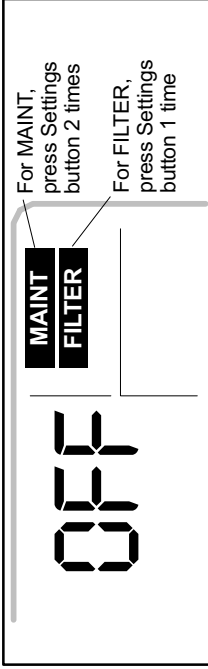

**Figure 14. Reminder Settings Display**

The default setting for the reminders is OFF (disabled). Press either the up or down arrow buttons to select the desired reminder intervals.

**Table 1. Filter and Maintenance Reminders**

Buttons to Use	Reminder	Available Settings and How to Use
<b>Settings</b> (1st press) then <b>Arrows</b> to scroll to selections	<b>FILTER</b>	Total fan run time expressed in months (Off, 1, 3, 6, 12); for example, if fan runs 12 hours a day, 1 month reminder displays in 2 calendar months.
<b>Settings</b> (2nd press) then <b>Arrows</b> to scroll to selections	<b>MAINT</b>	Elapsed chronological time in months (Off, 6, 12). Use this, for example, to remind yourself when to perform routine checks or when to call a technician for periodic preventive maintenance.
<b>Enter</b>		Stores settings.

**NOTE** - The HOME screen will reappear about 15 seconds after the final arrow button press. OR, press **ENTER** at any time to store any changes and exit to the HOME screen. After either programmed interval has elapsed, the reminder will be displayed as shown in figure 15.

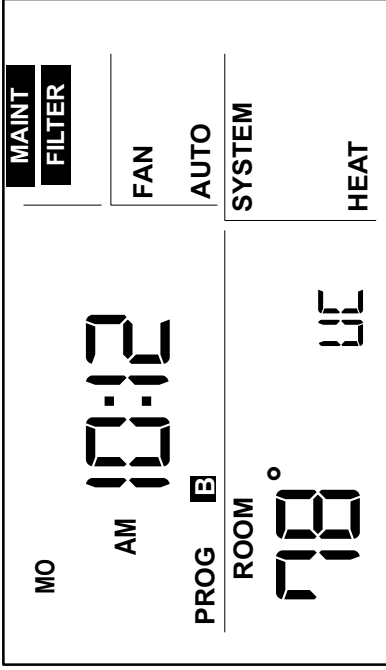

**Figure 15. Reminders**

After the filter has been changed or maintenance performed, reset the reminder by pressing the **SETTINGS** button for four seconds. The screen will blink for a few moments to indicate that the timer has been reset.

### Internal/Remote Sensor

If the optional Remote Indoor Sensor (10K) (47W37) is connected and configured it will serve as a room temperature sensor instead of using the internal temperature sensor built into the thermostat. The dip switch (position #4) is used to select either built-in or external

remote indoor temperature sensor used for temperature control.

### Occupied and Unoccupied Modes

During permanent hold mode the occupancy output follows the program. During two hour hold mode the user can change the occupancy status by pressing the enter button. The occupancy status will be changed to occupied **OC** or Unoccupied **UC** alternatively by pressing the enter button. The occupancy relay is turned on when the user selected the occupancy status during programming. The default state of the occupancy relay is off. The occupancy relay will turn on the economizer in the system

**Table 2. Thermostat Outputs (Occupancy)**

Demand Condition	W1	W2	OC	Y1	Y2	G
<b>Cooling Demands with Occupancy</b>						
First Stage Cooling			X	X		X
Second Stage Cooling			X	X	X	X
No Demand - Continuous mode			X			X
No Demand - Auto mode			X			
<b>Heating Demands with Occupancy</b>						
First Stage Heating	X		X			X
Second Stage heating	X	X	X			X
No Demand - Continuous mode			X			X
No Demand - Auto mode			X			X

### Service Indicator

When abnormal equipment operation is detected, the SERVICE indicator will flash on the screen (see figure 16). This indicates that the equipment requires service from a qualified service technician.

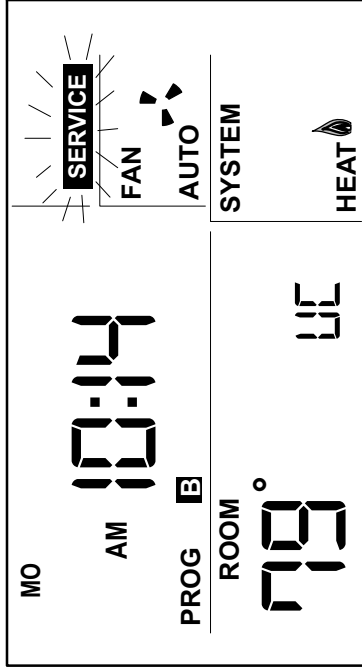

Figure 16. Service Indicator Flashing

### Thermostat RESET

Under some abnormal conditions, it may be necessary to “reset” the thermostat to its default condition. Such a RESET would delete all programming and settings and therefore should only be used on rare occasions when the thermostat fails to function as designed and/or as

programmed. Such an instance can occur as a result of a power surge or similar electrical disturbance (e.g. after an electrical storm or power outage). The RESET button can be used to recover from this situation.

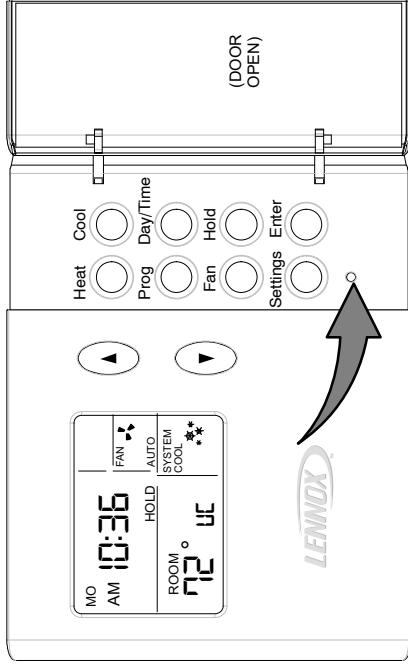

Figure 17. Reset Button

## CAUTION

When the RESET button is pressed, ALL settings revert back to their defaults (see tables 3 on page 13).

The RESET button is an unlabeled, recessed button located behind the door, on the right-hand side of the thermostat,

below the SETTINGS button (see figure 17). Use a paper clip or small pencil to press the RESET button; ALL thermostat settings will be reset to the defaults listed in the Default Thermostat Settings section.

### Removing/Installing Thermostat

The thermostat hinges on tabs on the top of the sub-base; no tool is needed to remove the thermostat from the sub-base. Pivot the bottom of the thermostat outward (releasing the snaps), then lift up to remove.

To replace it, first position the top tilted toward the wall bracket and align it until you feel the tabs and slots engage; then, while the top is in place, pivot the bottom toward the wall until the thermostat snaps into place.

### Default Thermostat Settings

Default thermostat settings are shown in table 3.

**Table 3. Default Thermostat Settings**

Mode	Heat (Permanent Hold Mode)
Setpoint	70°F (or 21°C)
Fan	Auto
Filter Reminder	OFF
Maintenance Reminder	OFF
Equipment Protection Timers	Reset Back to Zero

### Technical Specifications

#### Thermostat Type

Electronic programmable thermostat for non-heat pump, 2-stage heat / 2-stage cool.

#### Power Supply Range

18VAC - 30VAC (24VAC nominal), 50Hz<sup>1</sup> or 60Hz

**1 When the thermostat is used in 50Hz applications, the tolerance will be lowered leading to slight change in temperature control accuracy.**

## ⚠ CAUTION

24VAC is present on the terminals of the thermostat bracket. If removing the thermostat from the wall, use caution and avoid touching any of the connector terminals on the wall bracket.

Also, when working with the thermostat dip switches, use a non-conductive tool and take caution to avoid making any contact with the circuit board, its imprinted circuitry and its connector prongs.

#### Temperature Display

- Display Scale: Fahrenheit or Celsius user selectable
- Display range: 35°F (2°C) to 99°F (37°C)
- Display resolution: 1°F (1°C)
- Display Accuracy: +/-1°F

### Setting Temperature Scale

To select either Fahrenheit or Celsius, press **Settings** button three times. Press **up/down arrows** to toggle between Fahrenheit and Celsius. Once selected, press **Settings** button to exit.

### Selecting Internal or Remote Sensor

To select between the internal or remote temperature sensor use dip switch #4. Factor default setting is set to internal sensor (OFF)

### Temperature Measurement Range

- Measurement Scale: Fahrenheit
- Measurement Range: 35°F to 99°F
- Measurement Resolution: 0.125°F
- Measurement Accuracy: +/-1°F
- Field Offset: via DIP switches to +/-3°F

**Sampling Method:** Temperature measurements sampled every two seconds. Displayed temperature is the average of the last four measurements.

### Temperature Set Point Range

- Setting range: 50°F (10°C) to 90°F (32°C)
- Setting resolution: 1°F (1°C)

### Smooth Setback Recovery (via DIP switch #6)

Smooth Setback Recovery (SSR) affects the way the thermostat responds to program events. If SSR is disabled, the thermostat will react to a program event at the time the event occurs. However, if SSR is enabled, the thermostat will react to a program event before the event occurs such that the desired temperature is reached at the time of the event, not after.

### Fan Control

AUTO or ON modes.

### I/O Relays

All thermostat relays are latching type to minimize power consumption.

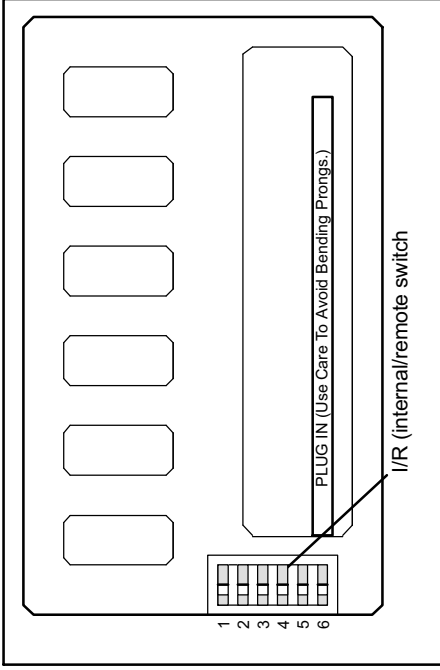

**Figure 18. Internal/Remote Sensor Settings**

**Table 4. Terminal Designations**

Terminal	Description
R	24VAC
Y1	Compressor Stage 1 cooling
W1	Stage 1 heating
Y2	Compressor Stage 2 cooling
W2	Stage 2 heating
G	Fan
L	Service indicator
C	Common 24VAC
T	Remote Temperature Sensor connection 2
T	Remote Temperature Sensor connection 2
OC	Occupancy output (economizer)

Minimum cycle time (applies to both furnace cycle and elapsed time) between any furnace activation and the next furnace activation): 6 minutes.

Minimum elapsed time between any compressor activation and the next compressor activation: 6 minutes.

**NOTE** - All protection timers (except the compressor OFF timer) can be over-ridden if a heating or cooling demand is initiated or terminated using the UP, DOWN, HEAT, or COOL buttons.

**Equipment Protection Override**

Both the minimum compressor OFF timer and the minimum equipment cycle timer can be over-ridden by pressing and holding either the HEAT or COOL button down for four seconds.

**Filter Reminder**

Settings of Off, 1, 3, 6 or 12 (months of fan run time) are available. When programmed time has elapsed, a FILTER indicator is displayed.

**Maintenance Reminder**

Settings of Off, 6 or 12 (months of chronological time) are available. When programmed time has elapsed, a maintenance indicator "MAINT" is displayed.

**Equipment Protection Timers**

- Minimum Compressor OFF time: 5 minutes
- Minimum Compressor ON time: 4 minutes
- Minimum Electric Heat ON time: 3 minutes
- Minimum Furnace ON time: 3 minutes
- Minimum Furnace OFF time: 1-1/2 minutes

### Service Reminder

The SERVICE indicator is displayed only under the following conditions:

- if the thermostat Y1 terminal has been activated with 24VAC for at least 5 minutes, AND the L terminal is shorted to the R terminal;
- OR
- if the thermostat Y1 terminal has been activated with 24VAC for at least 5 minutes, AND the L terminal is shorted to the C terminal.

### Power Loss/Recovery

Thermostat memory is retained for a minimum of 24 hours during a power loss (includes retention of program information, HOLD status, programmed temperature set point, heat/cool and fan mode settings, filter reminder status, maintenance reminder status, and equipment protection timers). After 24 hours of power loss, programmed settings will be lost and replaced with default settings.

# IMPORTANT

Power must be applied for at least six consecutive hours prior to a power loss in order for memory to be retained for the specified time.

### LCD Back Light

Activated for 30 seconds when any button is pressed.

**NOTE** - *During an electrical storm or similar disturbance, the back light may activate for a few seconds. This is normal and will no longer occur after the electrical disturbance has passed.*

### Thermostat Operating Conditions

32°F to 122°F, 10% to 90% RH

### Thermostat Storage Conditions

-40°F to 176°F, 10% to 90% RH



# ComfortSense® 7500 Thermostat User Guide

507503-02  
6/2018  
Supersedes 5/2017

## Table of Contents

<b>Features</b> .....	2
<b>Home Screen Temperature Indicator</b> .....	3
<b>Home Screen Information</b> .....	3
<b>Operating Mode Selection</b> .....	6
Fan Operation.....	6
<b>User Menu Screen</b> .....	7
Notifications.....	7
Reminders.....	8
Performance Report.....	8
Edit Schedules.....	8
<b>User Settings Menu</b> .....	10

## Features

The ComfortSense® 7500 Series thermostat is an electronic 7-day, universal, multi-stage, programmable, touchscreen thermostat. It also offers enhanced capabilities including humidification/dehumidification/dew point measurement and control, Humiditrol® EDA (Enhanced Dehumidification Accessory) control, and equipment maintenance reminders.

- Large, clear color display that shows the current and set temperature, time, indoor relative humidity and outdoor temperature (if optional outdoor sensor is installed and enabled).
- Dehumidification measurement and control.
- Humiditrol® EDA capability.
- Dew point adjustment control.

- Ergonomic design.
- Smooth Setback Recovery starts system early to achieve setpoint at start of program period.
- Compressor short-cycle protection (5 minutes).
- Real-time clock keeps time during power failures and automatically adjusts for daylight savings time and leap year.
- Maintenance reminders let user know when to service or replace filters, humidifier pads, ultraviolet lamps, plus two user or installer defined custom reminders.
- Program Hold options allow user to override the program schedule as desired by time and date.
- Select individual days or groups of days to set programming.
- Programmable fan offers increased performance when combined with whole home indoor air quality products.

## Home Screen Temperature Indicator

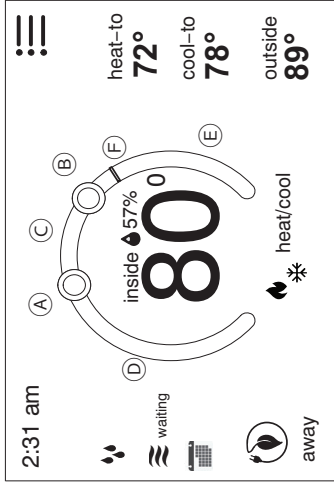

Figure 1. Temperature Dial Feature

- This is the heat set point position indicator on the dial. This object will be red in color.
- This is the cool set point position indicator on the Dial. This object will be blue in color.
- This is the location area where no system demand is active. In figure 1, the example would be any temperature between 73°F and 77°F.
- When there is an active call for heating, this area of the dial will fade back and forth from white to red.
- When there is an active call for cooling, this area of the dial will fade back and forth from white to blue.
- The yellow line indicates the actual room temperature on the temperature dial indicator.

## Home Screen Information

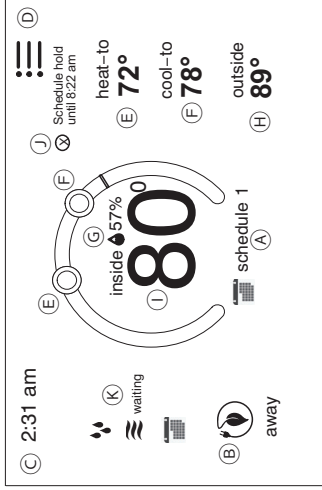



Figure 2. Home Screen





- Touch the screen to turn on the back-light if it is off.
- OPERATING MODE** - touch to access the screen that will list available modes. Selectable modes are heat/cool, heat only, cool only, off, emergency heat, schedule 1, schedule 2, and schedule 3. In addition fan operation can be set to on, auto or circulate.
  - AWAY**- Selecting **AWAY** will allow the user to set the heating and/or cooling mode temperatures when away from home. Touch **cancel** to exit this screen and return to the home screen and normal system operations.
  - Displays current time.
  - Menu** - This will allow access to notifications, performance report, schedules and settings.

- E. This allows you to set the heat-to (if enabled) temperature. Selecting the heat-to or temperature dial position indicator will take you to the temperature setting detail screen. The temperature dial will change from white to red when heating is active.
- F. This allows you to set the cool-to (if enabled) temperature. Selecting the cool-to or temperature dial position indicator will take you to the temperature setting detail screen. The dial will change from white to blue when cooling is active.
- G. Indicates the current indoor humidity percentage in the home along with a humidity icon (rain drop). The icon changes based on the humidity level in the home.
- H. This location could display the outdoor air temperature. What is displayed in that location depends on what sensor is installed and configured through the thermostat user interface. If neither is installed, then this area will be blank.
- I. Displays the current indoor temperature.
- J. Indicates the schedule is on hold until the next time period or permanent.
- Place the schedule on hold by touching on either the heat-to or cool-to location on the screen. If an adjustment is required for the temperature setting, this can be done now.
  - After approximately three seconds the screen will display the override setting options.
  - From the override setting screen, the options are 1 hour, 2 hour or next scheduled period. Make selection and then touch set.



- For the 1 or 2 hour setting the home screen will indicate schedule hold until time indicated (i.e., 11:57 pm). To exit schedule hold, touch .
- When until next period is selected, the set point will be kept until the next program schedule period. To exit until next period, touch .

K. **System Status Icons** - Equipment operation information appears along the left side of the home screen. The displayed icons will indicate cooling or heating demand, cooling compressor delay, or cooling demand.



**Table 1. System Status Icons**

Icon	Description <i>NOTE: Touching the icon will display a text description.</i>
	Humidifying icon is displayed when humidifying is occurring. Touching on the icon will display humidifying next to the icon.
	Dehumidifying icon is displayed when dehumidifying is occurring. Touching the icon will display dehumidifying next to the icon.
	Red flames indicates the system is heating.
	Blue flames indicates the system is cooling.

**Table 1. System Status Icons**

Icon	Description <b>NOTE:</b> <i>Touching the icon will display a text description.</i>
	<p>Snowflake indicates the next mode of operation will be cooling. Waiting indicates there is a compressor delay which is by default five minutes.</p>
	<p>Red flame indicates the next mode of operation will be heating. Waiting indicates there is a compressor delay (heat pump heating) which has a default of five minutes and is not adjustable.</p>
	<p>Indicates the system is running in emergency heat mode. All heat pumps operating in northern climates below 35°F (1.6°C) normally need a supplemental heating source. Usually it is in the form of electric heating provided by the indoor unit. Other sources could be gas, oil, or hot-water back-up systems as well. The supplemental heat is also referred to as "second-stage" or "back-up" heating, with "first-stage" being the heat pump only. Emergency heat is when you use your supplemental heat (2nd stage) by itself, without the use of your heat pump (1st stage heat). Not available for non-heat pump systems.</p>

**Table 1. System Status Icons**

Icon	Description <b>NOTE:</b> <i>Touching the icon will display a text description.</i>
	<p>Indicates the system is running in auxiliary heat mode. Is only available with heat pump system. If outdoor temperature is above the high balance point, only the heat pump will operate - default 50°F (10°C) high. If outdoor temperature is below the low balance point, only auxiliary heating will operate - default 25°F (-4.0°C) low. If outdoor temperature is in-between the high and low balance point, both the heat pump and auxiliary heat sources can operate.</p>
	<p>Transitioning to next schedule temperature setting. This icon will only appear if smooth setback recovery is enabled under the installer setup. When enabled, it will begin recovery up to two hours before the programmed time so that the programmed temperature is reached at the corresponding programmed event time. Assume 12°F per hour for gas/electric heating and 6°F per hour for first stage compressor based cooling. When smooth set back recovery is disabled, the control will start recovery at the programmed time set in the schedule.</p>

### Operating Mode Selection

Touch anywhere in the area indicated below to see how the system will operate.

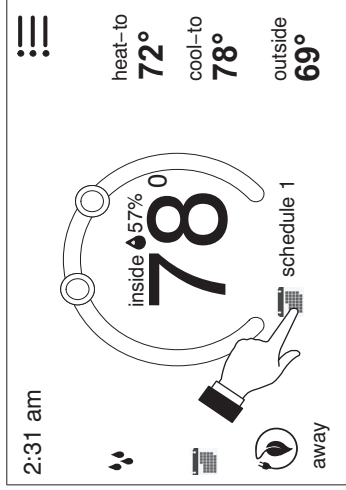

Figure 3. Operating Mode Selection

#### Select Modes

1. **HEAT/COOL** allows the thermostat to switch between heating and cooling automatically.
2. **HEAT ONLY** allows only heating demand.
3. **COOL ONLY** allows only cooling demand.
4. **OFF** indicates system has been turned off.
5. **EMERGENCY HEAT** allows heat pump system to use a secondary heat source to come on and reach the desired user temperature setting faster.

6. **SCHEDULES** (1, 2 or 3) See Edit Schedules on page 13 for customizing schedules).



7. **ON, AUTO and CIRCULATE** - Select by touching the desired fan operation **ON, AUTO** and **CIRCULATE**. When selected a green check mark will be indicated.

If **FAN** mode **AUTO, ON** or **CIRCULATE** is selected during scheduling for the current period, the thermostat will indicate the current fan mode in the information display (**FAN ON** or **FAN CIRC**). In the **CIRCULATE** mode, the fan will follow the setting configured under **menu > settings > fan > select fan mode**. Under circulate the circulate off time can be set from 1 to 30 minutes.

#### FAN OPERATION

The desired fan mode can be selected in addition to selected mode of operation.

Table 2. Fan Operation

Icon	Mode	Description
	on	Fan is NOT following the schedule and runs continuously until it is changed from the select mode.
	auto	Fan will follow the fan setting in the selected schedule.

**Table 2. Fan Operation**

Icon	Mode	Description
	circulate	Fan is following schedule and cycles during periods of equipment inactivity. Circulate off time is set by the user.

### User Menu Screen

Touch the three lines in the upper right-hand corner of the screen to access the menu. Selectable options under menu are notifications, performance report, edit schedules and settings.

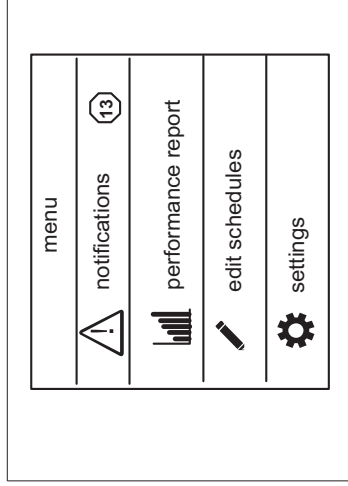

**Figure 4. User Menu Screen**

### NOTIFICATIONS

When a system error or reminder occurs, a pop-up screen will appear indicating the condition.

- Error code notification pop-up can be dismiss by touching the back button. Contact the dealer to resolve the issue.
- For notification, touch either clear or set a future reminder.
- Any active history for notifications (critical errors or reminders) will be listed under settings > notification.
- If critical errors occur, they will also be displayed under notifications as illustrated in figure 5.
- Touch the contractor info option for assistance.



**Figure 5. Critical Notifications**

## REMINDERS

When reminders occur, they will also be displayed under notifications as illustrated in figure 7. Touch the clear or remind later to redisplay active reminder for 1 day, 1 week, 1 month, 3 months or a custom date.

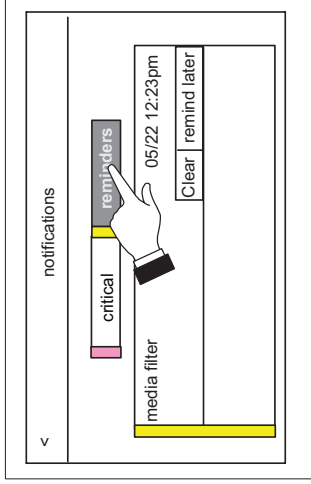

**Figure 6. Reminder Notifications**

## PERFORMANCE REPORT

This will display the total number of hours each month that the system has been running. Example would be for mar (March) 23H or 23 hours. To return to the menu screen, touch the house icon in the upper left-hand corner of the screen. Red bar indicates heating and blue indicates cooling hours ran.

## EDIT SCHEDULES

Any schedule can be edited by touching the right arrow next to the desired schedule.

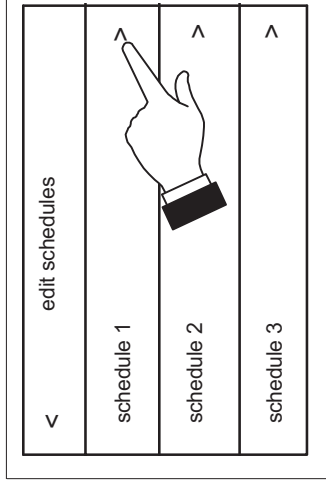

**Figure 7. Edit Schedules Screen**

**NOTES:** See “Operating Mode Selection” on page 6 to run a specific schedule.

From the HOME screen touch the MENU and touch edit schedules option.

The edit schedules screen will allow section of up to three separate schedules. On the edit schedules screen, each schedule can be renamed and edited.” See “Figure 8. Renaming and Editing Schedules” on page 9.

**NOTES:** The fan mode that is selected under the edit schedules screen will always override the fan mode selected under the select mode screen or user settings > fan screen if different

For example, if the select mode fan setting or **user settings > fan** is configured for Auto, and the schedule fan mode is set to circulate, then the system will follow the fan mode selected in the active schedule.

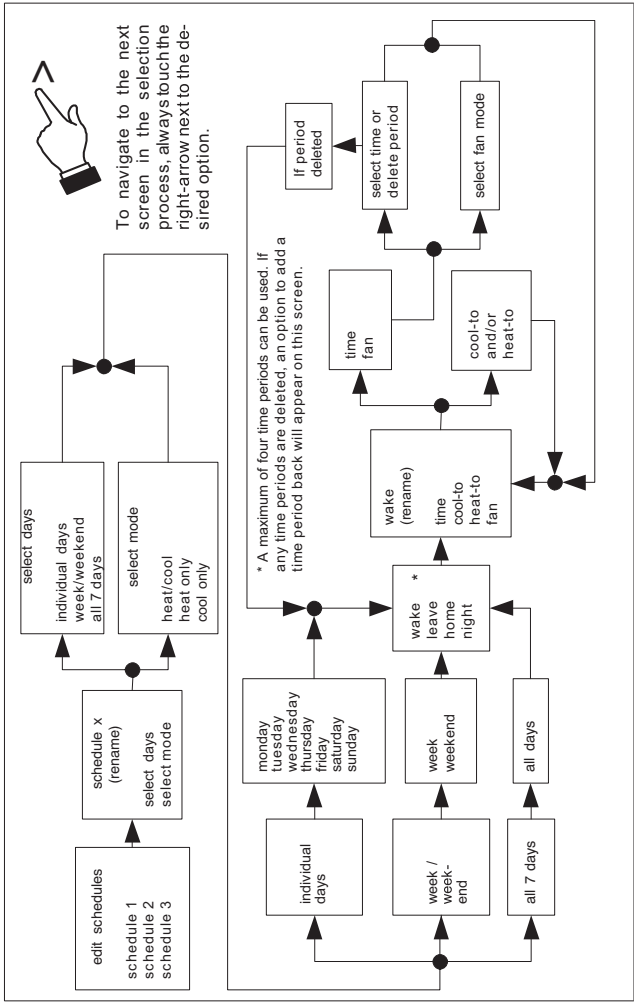

Figure 8. Renaming and Editing Schedules

## User Settings Menu

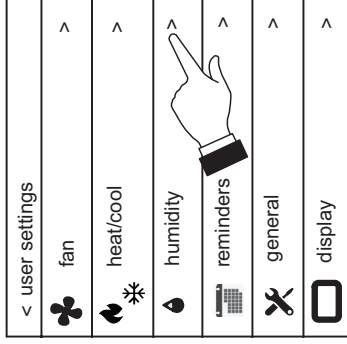

Figure 9. User Settings Menu

**Table 3. User Settings (General)**

Setting Selection	Function	Description
fan	See "Fan Operation" on page 6.	
	normal	Heats home to desired temperature setting. Options are on or off.
	comfort	If system is two-stage heating or cooling, then 2nd stage is locked in until demand is satisfied.
heat / cool (either heat pump, gas or electric heating is selected)	emergency heat	Bypasses the first stage of heating (any stage[s] of heat pump heating) and goes directly to the heat stage used for maximum heating to more quickly warm a very cold house.
	set point range	Heating limit with a default of 0°F. Range is 45°F to 90°F Cooling limit with a default of 45°F. Range is 45°F to 99°F
cool only (option only appears if no heating equipment is available or configured)	set point range	Cooling limit with a default of 45°F. Range is 45°F to 99°F
humidity - Allows selection of humidity mode which is humidifier only, dehumidifier only or both (humidifier + dehumidifier). (option only available if equipment installed and configured.)	humidity	Options are ON and OFF. Allows humidity setting adjustment between 15% to 45%. Default is 45%.
	dehumidify	Options are ON and OFF. Allows dehumidify adjustment setting between 45% to 60%. Default is 50%.
reminders - Items on this list are by default disabled.		Media filter, humidity pad, routine system check up, UV lamp, metal insert for PureAir and customer reminders 1 and 2*. Options for each reminder are disabled (default), 3mon, 6mon, 12mon, 24mon or a custom duration by specific date can be set. Once set an "expires on xx/xx/xx (date)" will be displayed next to the function. * Custom reminders 1 or 2 may have been renamed by the installer.

**Table 3. User Settings (General)**

Setting Selection	Function	Description
general - provides information about the thermostat and settings for screen lock, date & time and language.	about	Displays information concerning thermostat model number, serial number, hardware and software revisions.
	screen lock	Setting options are unlocked, partially, and locked.  To set partially lock, create a three digit code. Partially lock restricts access to the menu.  To set locked, create a three digit code. Lock restricts access to anything on the screen.  <b>NOTE:</b> <i>Partially Lock and Locked is set for one instance only. Either would need to be set each time it is desired to partially lock or locked the screen. Master code is 864 in case user forget their custom code.</i>
	date & time	Settings for 24-hour clock (military), daylight savings, set time and date.
	language	Languages available are English, Spanish, Portuguese and French.
	screen saver	Options are enable and disable. Default is enabled. When enabled only the time and inside temperature is displayed on the screen. Touching the screen will restore all other details. The back light setting is also on the same screen. Options are continuous on or energy save. Default is continuous on.
display - Allows the user to control some information that is displayed on the home screen.	screen brightness	A horizontal adjustment bar is provided to move from minimum to maximum brightness.
	temperature scale	°F for Fahrenheit or C° for Celsius.
	clean screen	This will disable the touchscreen for 30 seconds.

**Elite® Series CBA27UHE Units**

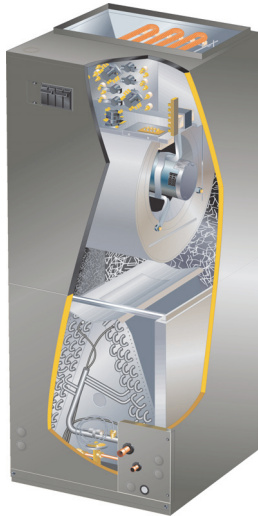

**Table of Contents**

Specifications / Electrical Data ..... Page 2

Blower Data ..... Page 4

Parts Arrangement ..... Page 6

I Application ..... Page 7

II Unit Components ..... Page 7

III Optional Electric Heat ..... Page 9

IV Start Up ..... Page 28

V Typical Operating Characteristics .. Page 28

VI Maintenance ..... Page 29

VII Wiring Diagrams and Sequence  
of Operations ..... Page 32

IT IS HIGHLY RECOMMENDED IF THE AIR HANDLER IS INSTALLED IN A UNCONDITIONED SPACE THAT A CIRCUIT BREAKER COVER (ORDERED SEPARATELY) IS USED. ORDER LENNOX CATALOG # 82W01.

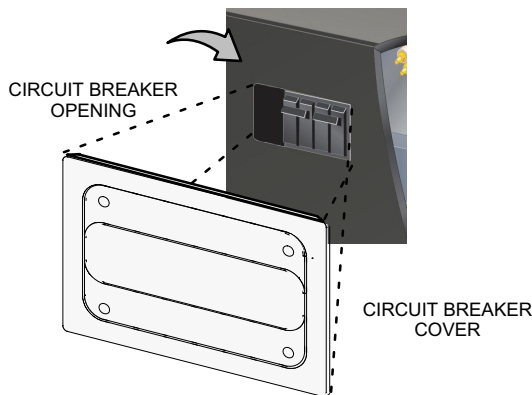

The Elite CBA27UHE units are high efficiency blower coils featuring **an all-aluminum coil**. Several models are available in sizes ranging from 1-1/2 through 5 tons (5.3 through 17.6 kW). The CBA27UHE is an upflow horizontal unit designed for HCFC-410A refrigerant. See unit installation instructions for more detail. A kit is available for downflow applications. CBA27UHE units come with a factory-installed check / expansion valve for cooling or heat pump applications.

CBA27UHE series units are designed to be matched with 14 SEER air conditioner or heat pump units. While these blower coil units are designed to be primarily matched with these outdoor units, they may be matched with other air conditioners or heat pumps as noted in the rating information.

ECB29 electric heat, in several voltages and kW sizes, can be field installed in the CBA27UHE cabinets.

Information contained in this manual is intended for use by experienced HVAC service technicians only. All specifications are subject to change. Procedures outlined in this manual are presented as a recommendation only and do not supersede or replace local or state codes.

**IMPORTANT:** Special procedures are required for cleaning the aluminum coil in this unit. See page 29 in this manual for information.

**⚠ WARNING**

Improper installation, adjustment, alteration, service or maintenance can cause personal injury, loss of life, or damage to property.

Installation and service must be performed by a licensed professional installer (or equivalent) or a service agency.

**⚠ CAUTION**

As with any mechanical equipment, contact with sharp sheet metal edges can result in personal injury. Take care while handling this equipment and wear gloves and protective clothing.

## SPECIFICATIONS

General Data		Model Number	CBA27UHE-018	CBA27UHE-024	CBA27UHE-030	CBA27UHE-036
Nominal tonnage			1.5	2	2.5	3
Connections	Suction (vapor) line (o.d.) - in. sweat		3/4	3/4	3/4	3/4
	Liquid line (o.d.) - in. sweat		3/8	3/8	3/8	3/8
	Condensate - in. fpt		(2) 3/4	(2) 3/4	(2) 3/4	(2) 3/4
Indoor Coil	Net face area - ft. <sup>2</sup>		4.44	4.44	5.0	5.0
	Tube outside diameter - in.		3/8	3/8	3/8	3/8
	Number of rows		3	3	3	3
	Fins per inch		12	12	12	12
Blower	Wheel nominal diameter x width - in.		10 x 8	10 x 8	11 x 8	11 x 8
	Blower motor output - hp		1/2	1/2	1/2	1/2
<sup>1</sup> Filters	Size of filter - in.		20 x 20 x 1	20 x 20 x 1	20 x 20 x 1	20 x 20 x 1
Shipping Data -1 package - lbs.			137	137	150	150

## ELECTRICAL DATA

	Voltage - 1 phase - 60hz	208/230V-1ph	208/230V-1ph	208/230V-1ph	208/230V-1ph
	Voltage - 3 phase - 60hz	---	---	---	<sup>3</sup> 460V-1ph
<sup>2</sup> Maximum Overcurrent Protection (unit only) - All voltages		15	15	15	15
Minimum Circuit Ampacity (unit only) - 208/230V		5	5	5	5
Blower Motor Full Load Amps - 208/230V		4.1	4.1	4.1	4.1
Minimum Circuit Ampacity (unit only) - 460V		---	---	---	2.6
Blower Motor Full Load Amps - 460V		---	---	---	2.1

<sup>1</sup> Disposable frame type filter.

<sup>2</sup> HACR type circuit breaker or fuse.

<sup>3</sup> Blower motor is 460V - 1 phase. Optional electric heat is 460V - 3 phase.

## SPECIFICATIONS

General Data		Model Number	CBA27UHE-042	CBA27UHE-048	CBA27UHE-060
	Nominal tonnage		3.5	4	5
Connections	Suction (vapor) line (o.d.) - in. sweat		7/8	7/8	7/8
	Liquid line (o.d.) - in. sweat		3/8	3/8	3/8
	Condensate - in. fpt		(2) 3/4	(2) 3/4	(2) 3/4
Indoor Coil	Net face area - ft. <sup>2</sup>		7.22	7.22	8.33
	Tube outside diameter - in.		3/8	3/8	3/8
	Number of rows		3	3	3
	Fins per inch		12	12	12
Blower	Wheel nominal diameter x width - in.		12 x 9	12 x 9	12 x 9
	Blower motor output - hp		1	1	1
<sup>1</sup> Filters	Size of filter - in.		20 x 24 x 1	20 x 24 x 1	20 x 24 x 1
Shipping Data -1 package lbs.			186	186	199

## ELECTRICAL DATA

	Voltage - 1 phase - 60hz		208/230V-1ph	208/230V- 1ph	208/230V- 1ph
	Voltage - 3 phase - 60hz		---	<sup>3</sup> 460V-1ph	<sup>3</sup> 460V-1ph
<sup>2</sup> Maximum Overcurrent Protection (unit only) - All voltages			15	15	15
Minimum Circuit Ampacity (unit only) - 208/230V			10	10	10
Blower Motor Full Load Amps - 208/230V			7.6	7.6	7.6
Minimum Circuit Ampacity (unit only)V - 460V			---	5	5
Blower Motor Full Load Amps - 460V			---	4	4

<sup>1</sup> Disposable frame type filter.

<sup>2</sup> HACR type circuit breaker or fuse.

<sup>3</sup> Blower motor is 460V - 1 phase. Optional electric heat is 460V - 3 phase.

**BLOWER DATA**

**CBA27UHE-018 BLOWER PERFORMANCE**

External Static Pressure in. w.g.	Air Volume and Motor Watts									
	Tap 1		Tap 2		Tap 3		Tap 4		Tap 5	
	cfm	Watts	cfm	Watts	cfm	Watts	cfm	Watts	cfm	Watts
.10	717	66	707	63	735	74	781	81	959	133
.20	596	58	570	54	636	70	737	91	922	144
.30	473	56	430	48	603	77	697	101	877	150
.40	402	61	335	54	540	81	651	105	846	161
.50	358	67	302	60	492	92	607	117	811	173
.60	295	74	248	63	434	94	561	121	769	179
.70	262	79	202	72	399	103	507	131	727	187
.80	N/A	N/A	N/A	N/A	348	108	459	137	695	196

**CBA27UHE-024 BLOWER PERFORMANCE**

External Static Pressure in. w.g.	Air Volume and Motor Watts									
	Tap 1		Tap 2		Tap 3		Tap 4		Tap 5	
	cfm	Watts	cfm	Watts	cfm	Watts	cfm	Watts	cfm	Watts
.10	767	78	753	75	826	88	957	131	1095	189
.20	662	68	648	66	791	100	937	142	1063	199
.30	615	76	612	77	750	108	895	149	1040	211
.40	561	83	539	83	711	116	861	160	1010	226
.50	522	87	507	89	681	126	821	172	970	230
.60	450	96	438	93	628	134	778	175	944	237
.70	419	100	411	103	584	142	750	186	905	248
.80	365	110	358	108	521	147	702	194	864	256

**CBA27UHE-030 BLOWER PERFORMANCE**

External Static Pressure in. w.g.	Air Volume and Motor Watts									
	Tap 1		Tap 2		Tap 3		Tap 4		Tap 5	
	cfm	Watts	cfm	Watts	cfm	Watts	cfm	Watts	cfm	Watts
.10	1061	115	1104	126	1169	154	1212	166	1278	200
.20	941	103	973	118	1070	144	1157	173	1241	210
.30	789	90	848	104	1019	151	1121	185	1201	223
.40	640	83	789	111	991	165	1077	199	1169	233
.50	525	93	728	118	946	175	1038	209	1124	244
.60	469	101	629	128	900	181	1006	215	1100	256
.70	434	104	581	139	851	194	956	230	1051	268
.80	365	116	521	155	754	208	915	237	1000	275

**CBA27UHE-036 BLOWER PERFORMANCE**

External Static Pressure in. w.g.	Air Volume and Motor Watts at 208V									
	Tap 1		Tap 2		Tap 3		Tap 4		Tap 5	
	cfm	Watts	cfm	Watts	cfm	Watts	cfm	Watts	cfm	Watts
.10	1074	134	1099	147	1264	206	1343	240	1498	340
.20	962	121	1027	143	1222	220	1291	253	1467	344
.30	887	126	989	153	1192	234	1269	266	1433	364
.40	852	136	944	164	1144	242	1224	280	1391	378
.50	791	150	894	172	1111	257	1194	286	1365	383
.60	717	160	820	186	1067	266	1153	297	1320	398
.70	649	168	745	202	1037	270	1118	309	1290	407
.80	606	183	697	213	999	284	1081	317	1247	422

**BLOWER DATA**

**CBA27UHE-042 BLOWER PERFORMANCE**

External Static Pressure in. w.g.	Air Volume and Motor Watts									
	Tap 1		Tap 2		Tap 3		Tap 4		Tap 5	
	cfm	Watts	cfm	Watts	cfm	Watts	cfm	Watts	cfm	Watts
.10	1282	177	1346	201	1497	261	1489	261	1723	396
.20	1143	159	1278	204	1475	281	1461	273	1690	408
.30	1067	162	1233	209	1447	297	1427	290	1656	434
.40	1024	175	1199	223	1406	315	1407	305	1639	436
.50	920	189	1154	235	1376	320	1360	324	1599	462
.60	923	197	1099	252	1345	338	1328	336	1573	473
.70	838	204	1022	267	1294	358	1303	351	1541	485
.80	815	218	1003	275	1238	375	1228	373	1494	515

**CBA27UHE-048 BLOWER PERFORMANCE**

External Static Pressure in. w.g.	Air Volume and Motor Watts									
	Tap 1		Tap 2		Tap 3		Tap 4		Tap 5	
	cfm	Watts	cfm	Watts	cfm	Watts	cfm	Watts	cfm	Watts
.10	1359	190	1509	257	1718	362	1773	401	1903	511
.20	1238	174	1473	273	1690	380	1758	419	1899	515
.30	1135	172	1453	289	1658	397	1707	434	1868	535
.40	1090	180	1450	290	1619	412	1687	449	1830	553
.50	1032	195	1374	315	1588	431	1660	465	1801	558
.60	980	204	1336	331	1561	440	1618	472	1770	582
.70	929	223	1295	339	1510	457	1593	493	1733	600
.80	867	235	1227	363	1488	473	1552	508	1703	618

**CBA27UHE-060 BLOWER PERFORMANCE**

External Static Pressure in. w.g.	Air Volume and Motor Watts									
	Tap 1		Tap 2		Tap 3		Tap 4		Tap 5	
	cfm	Watts	cfm	Watts	cfm	Watts	cfm	Watts	cfm	Watts
.10	1404	206	1704	340	1886	453	1928	481	2268	800
.20	1295	194	1658	349	1849	467	1905	510	2228	829
.30	1256	204	1631	365	1806	489	1869	525	2192	830
.40	1199	217	1594	386	1784	505	1842	546	2169	856
.50	1145	236	1549	394	1751	523	1799	548	2136	870
.60	1091	248	1508	413	1720	534	1775	569	2106	894
.70	978	270	1474	433	1683	549	1741	592	2089	907
.80	946	279	1440	453	1655	566	1709	611	2050	925

**REPLACEMENT CIRCUIT BREAKERS**

Voltage	Description	Catalog No.	Voltage	Description	Catalog No.
208/240V – 1 Phase	25 amp, 2 pole	<b>41K13</b>	208/240V – 3 Phase	30 amp, 3 pole	<b>64W47</b>
	30 amp, 2 pole	<b>17K70</b>		35 amp, 3 pole	<b>41K14</b>
	35 amp, 2 pole	<b>72K07</b>		40 amp, 3 pole	<b>41K16</b>
	40 amp, 2 pole	<b>49K14</b>		45 amp, 3 pole	<b>18M86</b>
	45 amp, 2 pole	<b>17K71</b>		50 amp, 3 pole	<b>41K15</b>
	50 amp, 2 pole	<b>41K12</b>		60 amp, 3 pole	<b>41K17</b>
	60 amp, 2 pole	<b>17K72</b>			

# CBA27UHE PARTS ARRANGEMENT

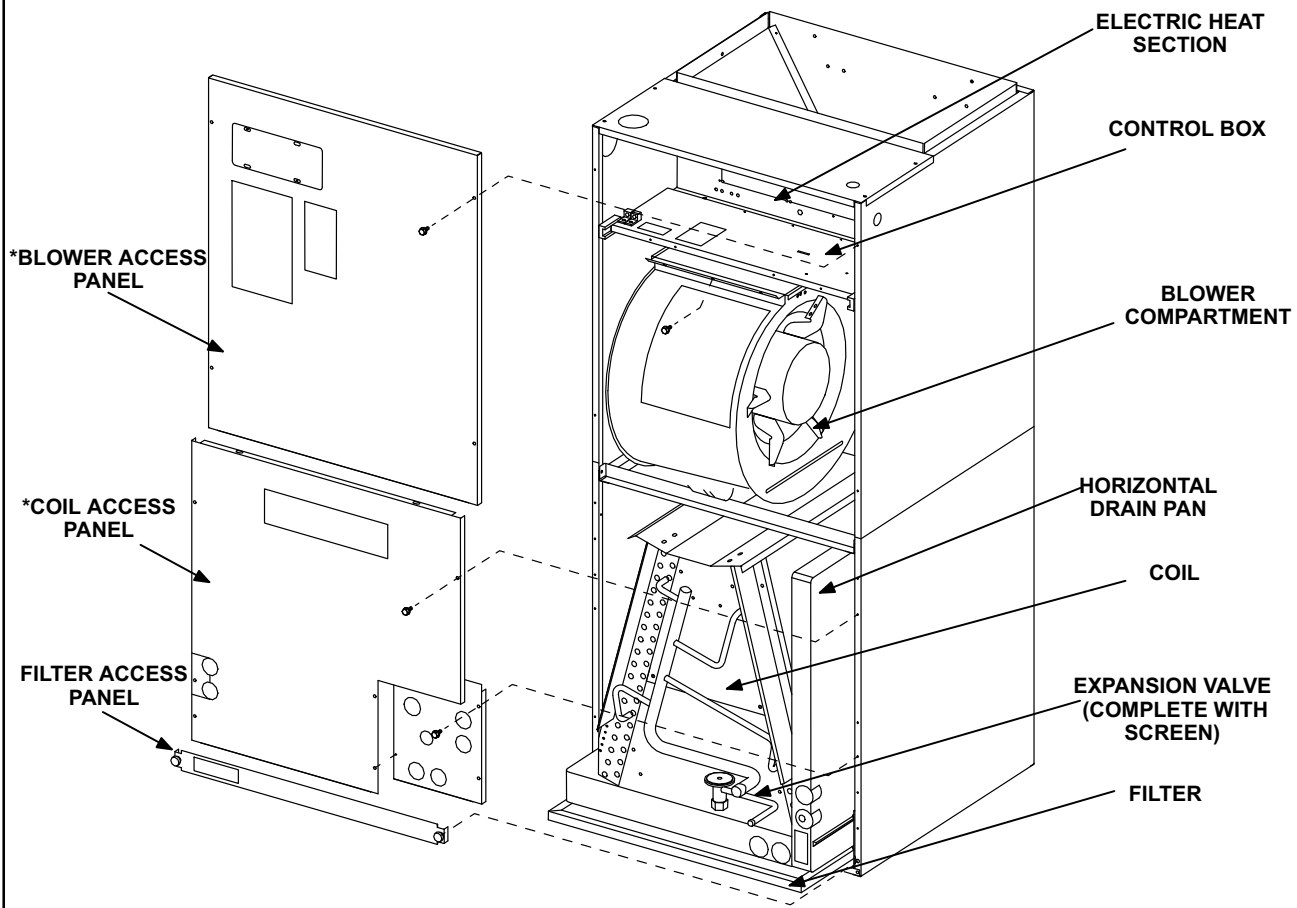
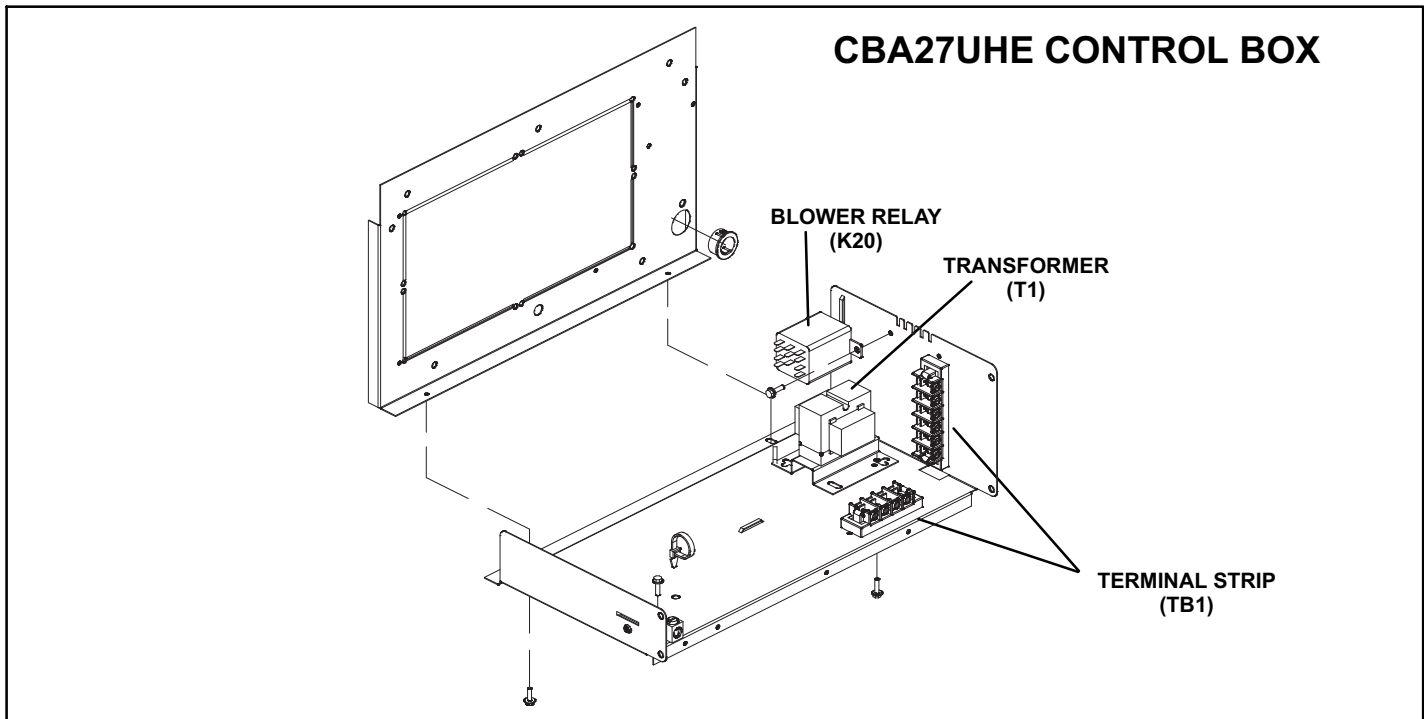

FIGURE 1



**FIGURE 2**

**I-APPLICATION**

All major blower coil components must be matched according to Lennox recommendations for the unit to be covered under warranty. Refer to the Product Specifications (EHB) for approved system matchups. A misapplied system will cause erratic operation and can result in early unit failure. The units come with factory installed check / expansion valve for all applications. The TXV valve has been installed internally for a cleaner installation and is accessible if required.

**ELECTROSTATIC DISCHARGE (ESD)  
Precautions and Procedures**

**⚠ CAUTION**

Electrostatic discharge can affect electronic components. Take precautions during unit installation and service to protect the unit's electronic controls. Precautions will help to avoid control exposure to electrostatic discharge by putting the unit, the control and the technician at the same electrostatic potential. Neutralize electrostatic charge by touching hand and all tools on an unpainted unit surface before performing any service procedure.

**II-UNIT COMPONENTS**

**A-Control Box**

See figure 2 for CBA27UHE control box. Line voltage and electric heat connections are made in the control box. Optional electric heat fits through an opening located in the center of the control box. When electric heat is not used, knock out plates cover the opening. The electric heat control arrangement is detailed in the electric heat section of this manual.

**B-Terminal Strip (TB1)**

CBA27UHE units are equipped with a low voltage terminal strip (TB1) located in the control box. See figure 2. The strip is used for making up all indoor thermostat wires. The outdoor unit low voltage wiring connections to TB1 may be spliced with wire nuts inside the CB units.

*Y1 to Y2 Jumper*

A factory installed jumper will be installed between "Y1 and "Y2" for single-stage stage cooling. Remove the jumper for two-stage cooling.

*R to W2 Jumper*

A factory installed jumper will be installed between "R" and "W2" for single-stage heat pump applications. Remove the jumper for two-stage non-heat-pump application.

## C-Transformer (T1)

CBA27UHE series units use a single line voltage to 24VAC transformer mounted in the control box. The transformer supplies power to the control circuits in the indoor and outdoor unit. Transformers are rated at 70VA. 208/240VAC single phase transformers use two primary voltage taps as shown in figure 3.

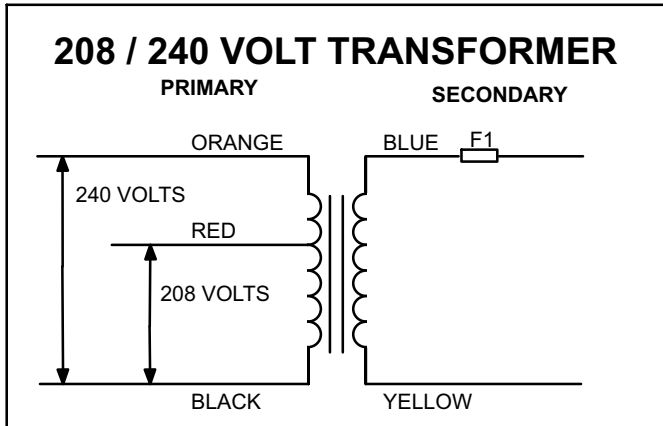

FIGURE 3

## D- Fuse (F1)

All transformers used in the CBA27UHE series units have a fuse (F1) wired in series on the low secondary side. See figure 3. F1 provides secondary voltage overcurrent protection and is rated at 3 amps.

## E-Blower Relay (K20)

CBA27UHE units use a DPDT relay to energize the blower motor during a call for *electric heat only*. When the relay coil is energized on an electric heat call, a set of N.O. contacts closes to energize the blower motor on heating speed.

## F-Dehumidification Relay (K183)

Relay K183 is used for dehumidification during cooling demand. K183 decreases blower speed resulting in an increase in the amount of moisture taken from the air. See wiring diagram on page Page 44 and operation sequence on Page 44 for more detail.

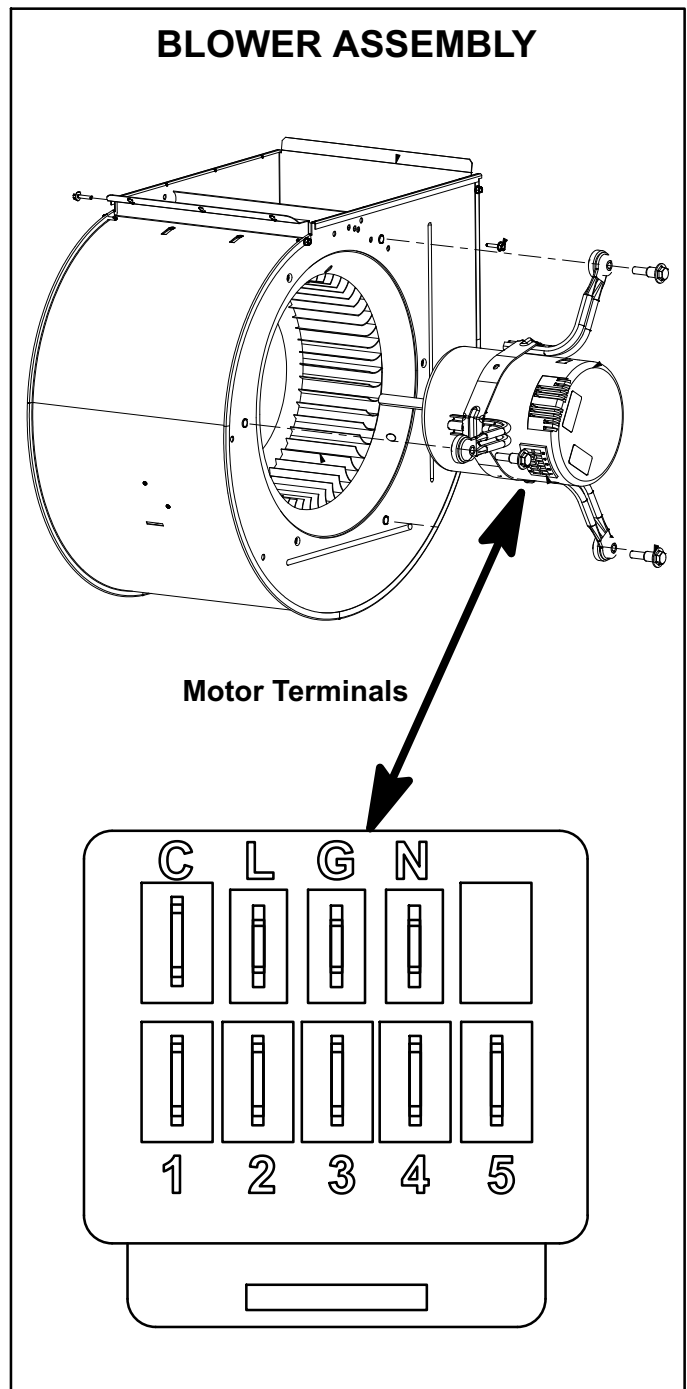

FIGURE 4

## G-Blower Motor (B3)

### ⚠ IMPORTANT

Blower motor features programmed electronic braking. The integral control brakes the motor near the end of the supply air blower operation, allowing the motor to maintain a more controlled ramping shut-down. Each blower is statically and dynamically balanced as an assembly before installation in the unit.

CBA27UHE units are equipped with an indoor blower motor that is permanent magnetic with constant torque. The motor has 5 signal level speed taps, all referenced to the same signal common. Each tap requires 24 volts to energize.

### Multiple Taps Energized

It is acceptable to have more than one tap energized at once but the micro-controller (integrated in the motor) will default to the highest tap. For example tap five will have precedence over tap four.

### Input Voltage Requirements

The circuit is designed to be operated with AC voltage. To enable a tap requires 12 to 33VAC. Expected current draw will be less than 20mA.

### Troubleshooting

Troubleshooting the motor is an easy process. Follow steps below.

- 1- Shut off power to unit.
- 2- Remove input plug from motor. Turn power back on to unit.
- 3- Check for 230 volts across terminals "L" and "N" on the input plug. See figure 4. If voltage is present continue. If voltage is not present problem may be up stream of the motor input plug.
- 4- Check for 24 volts across terminals "C" and speed tap used (1, 2, 3, 4 or 5) on the input plug. See figure 4. If 24 volts is not present problem may be up stream of the motor input plug.

If correct voltage is present in steps 3 and 4 and motor is not operating properly, replace motor. The motor is not field repairable.

### H-Coil

CBA27UHE units have dual slab coils arranged in an "A" configuration. Each coil has two or three rows of aluminum tubes fitted with ripple-edged aluminum fins. An expansion valve complete with screen, feeds multiple parallel circuits through the coils. The coil is designed to easily slide out of the unit cabinet.

### I-Condensate Drain Pans

Both upflow/downflow and horizontal drain pans are provided and installed on the CBA27UHE units. The drain pans are made from fiberglass filled plastic. The drain hole on horizontal pans are used for right-hand discharge only, and must be plugged when the unit is configured for left-hand discharge.

## III-OPTIONAL ECB29 ELECTRIC HEAT

### A-Matchups and Ratings

The Electric Heat Data on pages 15-25 show all approved

CBA27UHE to ECB29 matchups and electrical ratings.

### B-Electric Heat Components

ECB29 parts arrangement is shown in figures 5 through 10. All electric heat sections consist of components mounted to the electric heat vestibule panel and electric heating elements exposed directly to the air stream. 208/230V electric heat sections may be equipped with circuit breakers. The circuit breakers are designated by CB in the model number. The electric heat section is connected to the unit via jack J2, which plugs into plug P2 of the unit.

### Electric Heat Sequencer Relays

#### (K32, K33, K34, K35, K116, K117) (208/230 volt only)

Relays K32, K33, K34, K35, K116 and K117 are N.O. sequencer relays with a resistive element for a coil and a bi-metal disk which actuates the contacts. The relays are located on the electric heat vestibule panel and are energized by a 24V heating demand (W1, W2, and W3) via jack/plug 2. When energized, the internal resistance heats the bi-metal disk causing the contacts to close. When the relay is de-energized, the disk cools and the contacts open. The relays energize different stages of heat, as well as the blower. The blower is always first on and last off.

### Primary(S15) & Secondary(S20) Temperature Limits

Both the primary (S15) and secondary (S20) limits are located on the electric heat vestibule panel and are exposed directly to the air stream through an opening in the panel. The high temperature limits are SPST N.C. limits with the primary limit being an auto-reset limit and the secondary limit being a "one-time" limit. One-time limits need to be replaced when opened. The limits are factory set and are not adjustable.

### 208/230 Volt Electric Heat Sections

Each stage of the 208/230 electric heat is protected by a primary (S15) and secondary (S20) high temperature limit. Both S15 and S20 are located in the same housing. Each stage use the same style of limits. Both the primary and secondary limits are wired in series with a heat element. When either S15 or S20 opens, the corresponding heat element is de-energized. All other heating elements remain energized. The primary high temperature limit opens at 150°F ± 5°F (65.5°C ± 2.8°C) on a temperature rise and automatically resets at 110°F ± 9°F (43.3°C ± 5.0°C) on a temperature fall. The secondary high temperature limit opens at 333°F ± 10°F (167.2°C ± 5.6°C) on a temperature rise. If the secondary limit opens it will need to be replaced.

### Circuit Breaker (CB1, CB2, and CB3) (208/230 volt only)

Line voltage connections are made to circuit breakers CB1, CB2, and CB3 in the electric heat sections with circuit breakers (designated by CB in the model numbers) then routed to the CB unit through J/P2. The Electric Heat Data on pages 15-25 show the amp rating for each circuit breaker used. Single-phase electric heat uses two-pole circuit breakers; while three-phase electric heat uses three-pole circuit breakers.

### Terminal Strip (TB2) 208/230 volt only

For the electric heat sections without circuit breakers or fuses, line voltage connections are made to terminal strip

TB2 then routed to the CB unit through J/P2. The terminal strip is located in the lower left corner of the electric heat vestibule panel. Single-phase electric heat uses two-pole terminal strips; while three-phase electric heat uses three-pole terminal strips.

### Heating Elements (HE1 through HE6)

Heating elements are composed of helix wound bare nichrome wire exposed directly to the air stream. The elements are supported by insulators mounted to the wire frame. For single-phase applications, one element is used per stage. Each stage is energized independently by the corresponding relay located on the electric heat vestibule panel. All three-phase heating elements are arranged in a three-phase delta. Once energized, heat transfer is instantaneous. High temperature protection is provided by primary and secondary high temperature limits.

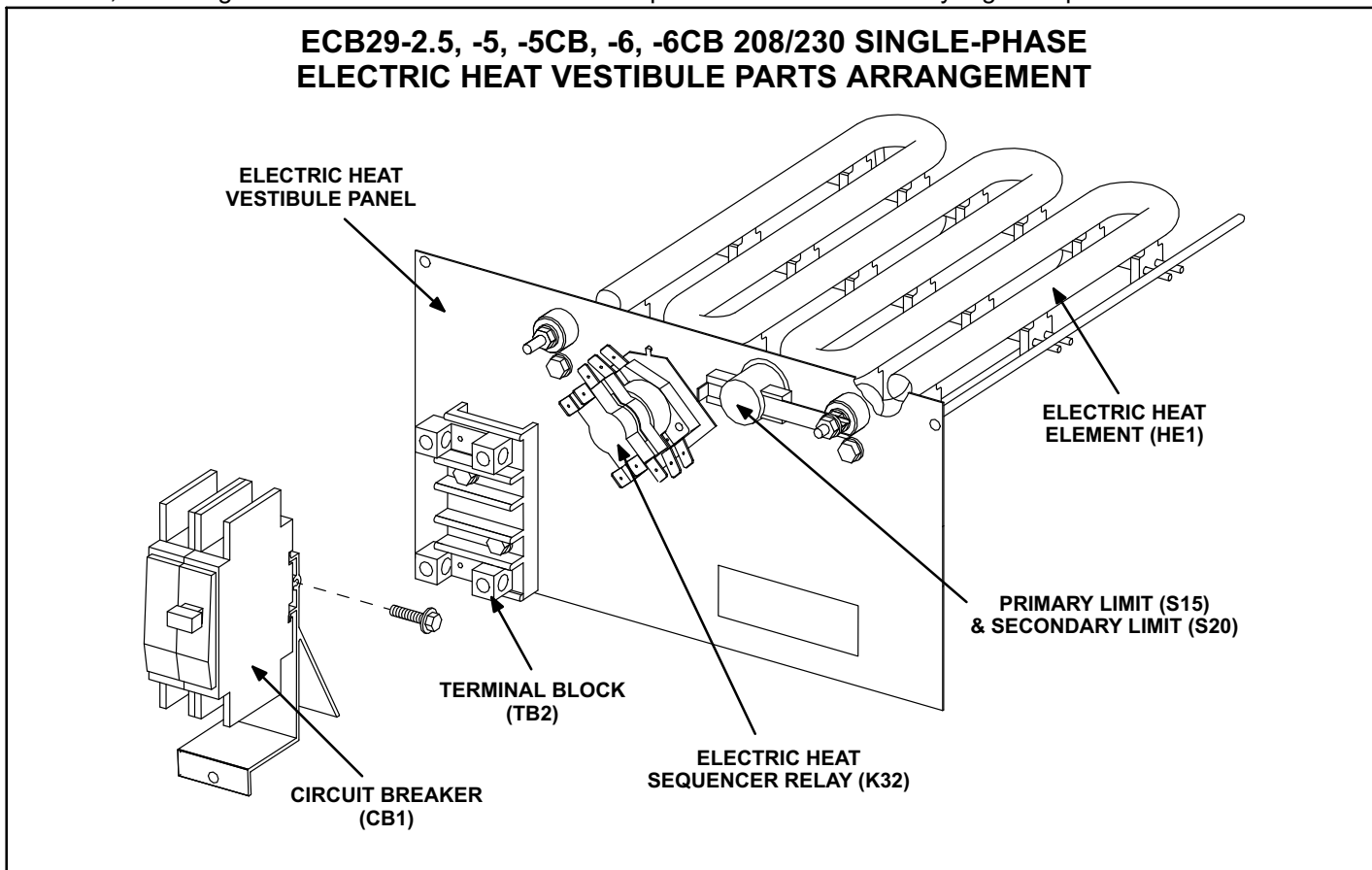

FIGURE 5

ECB29-8, -8CB, 9CB, -10, -10CB 208/230  
SINGLE-PHASE  
ELECTRIC HEAT VESTIBULE PARTS ARRANGEMENT

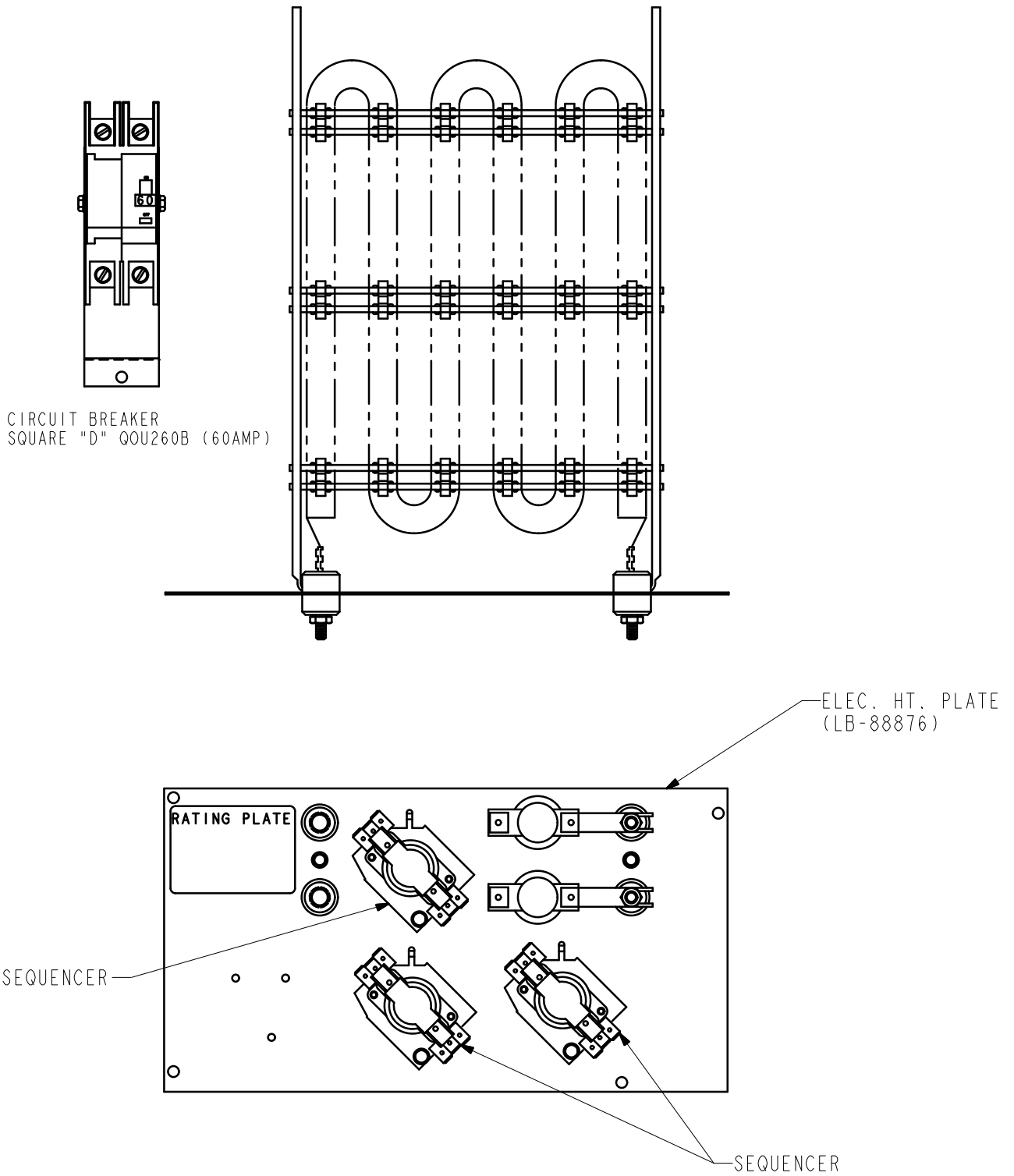

FIGURE 6

ECB29-12.5CB, -15CB 208/230 SINGLE PHASE  
ELECTRIC HEAT VESTIBULE PARTS ARRANGEMENT

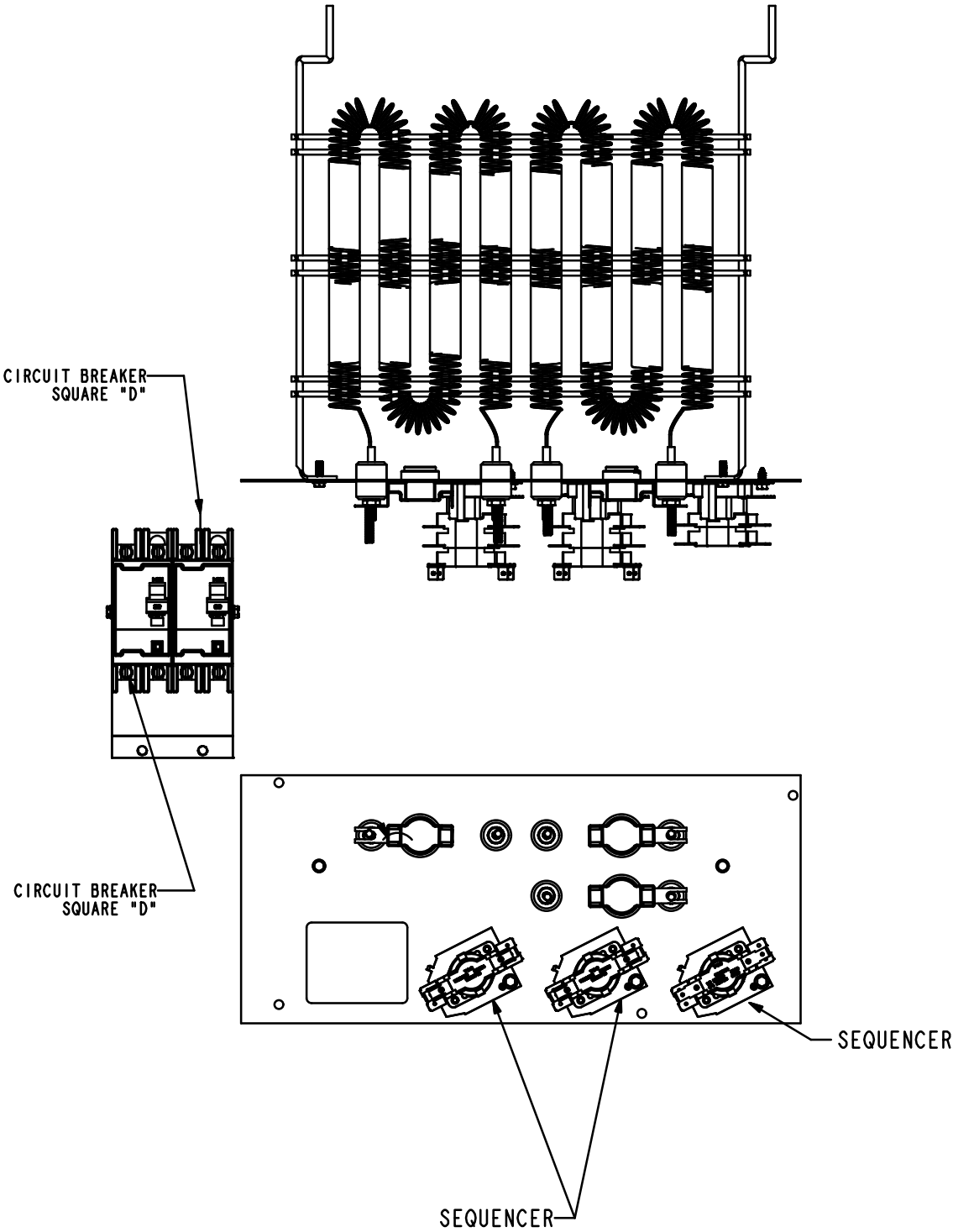

FIGURE 7

ECB29-8, -10 208/230 THREE PHASE  
ECB29-15CB 208/230 THREE PHASE  
ELECTRIC HEAT VESTIBULE PARTS ARRANGEMENT

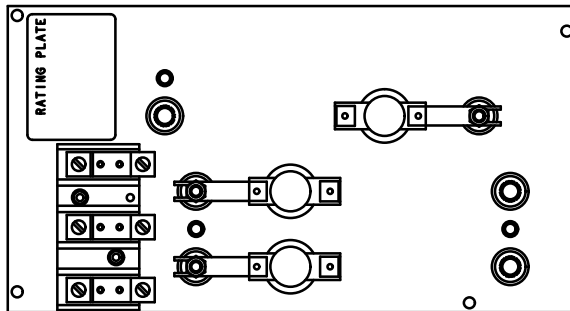
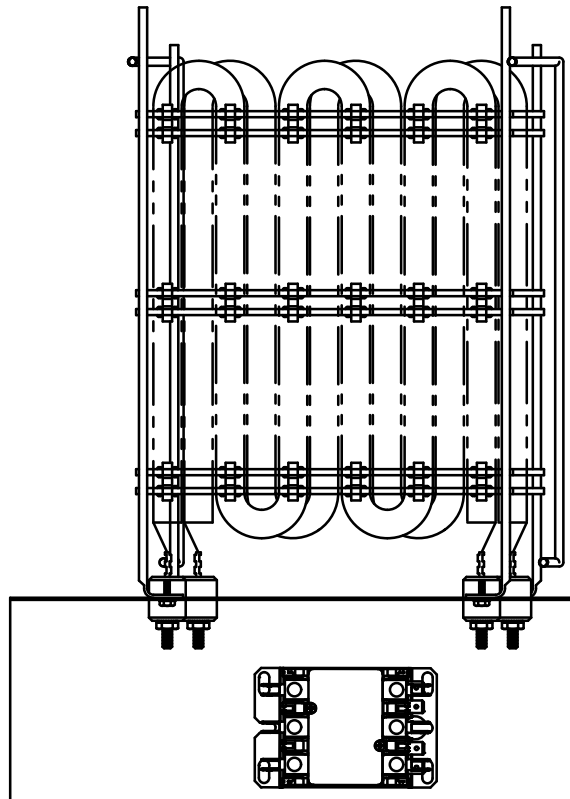
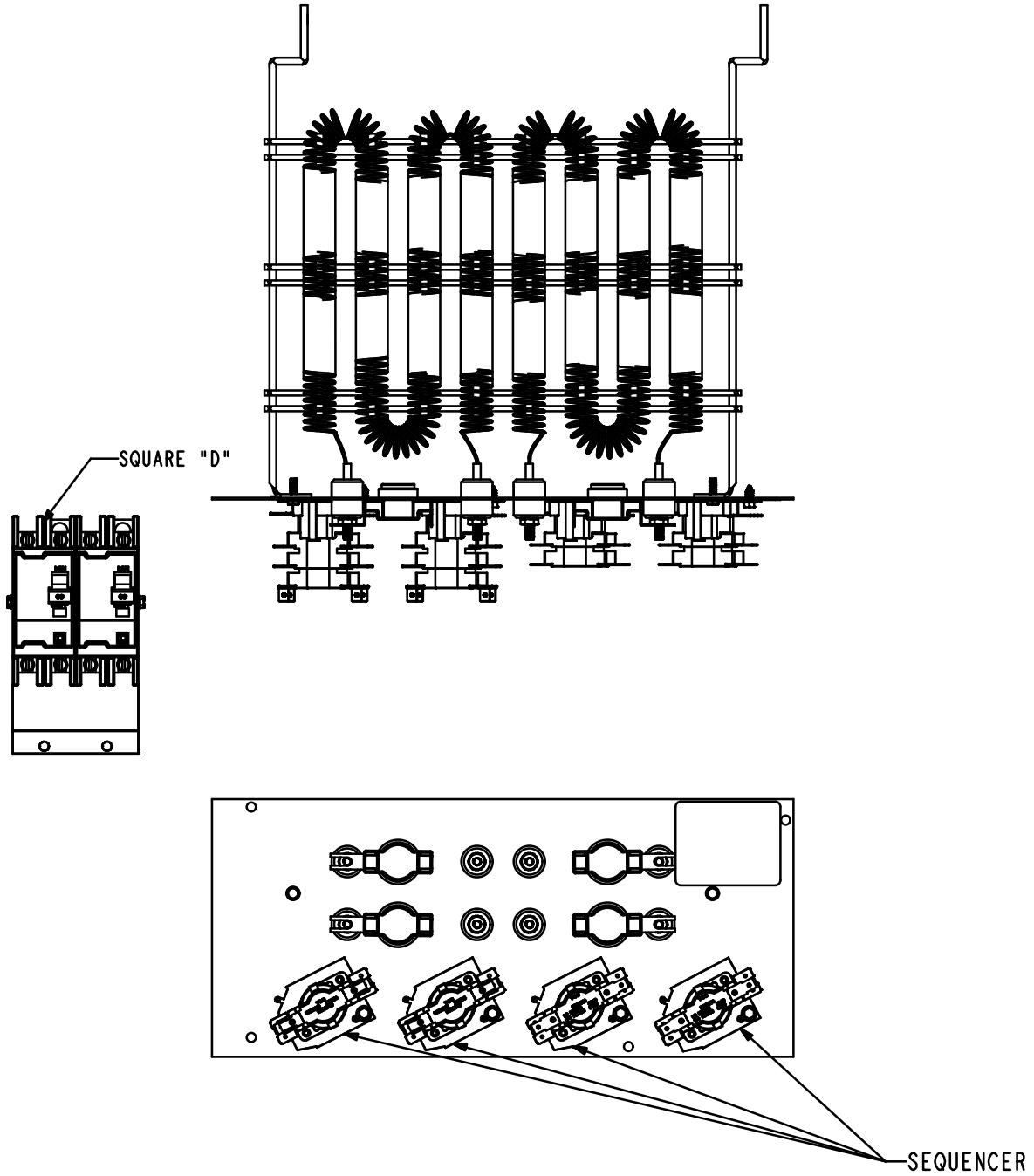

FIGURE 8

**ECB29-20CB 208/230 SINGLE-PHASE  
ELECTRIC HEAT VESTIBULE PARTS ARRANGEMENT**



**FIGURE 9**

ECB29-25CB, -30CB 208/230 SINGLE-PHASE  
ELECTRIC HEAT VESTIBULE PARTS ARRANGEMENT

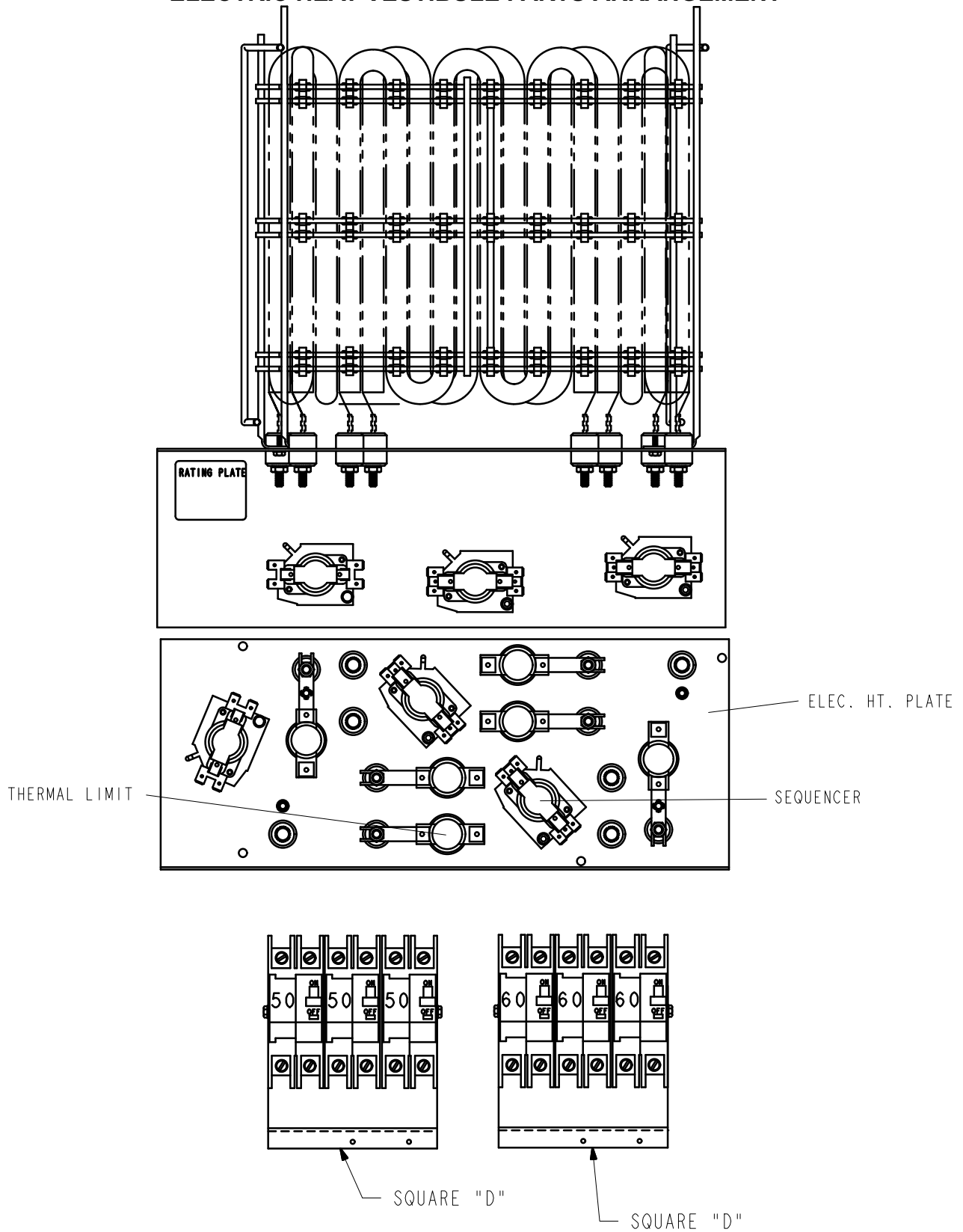
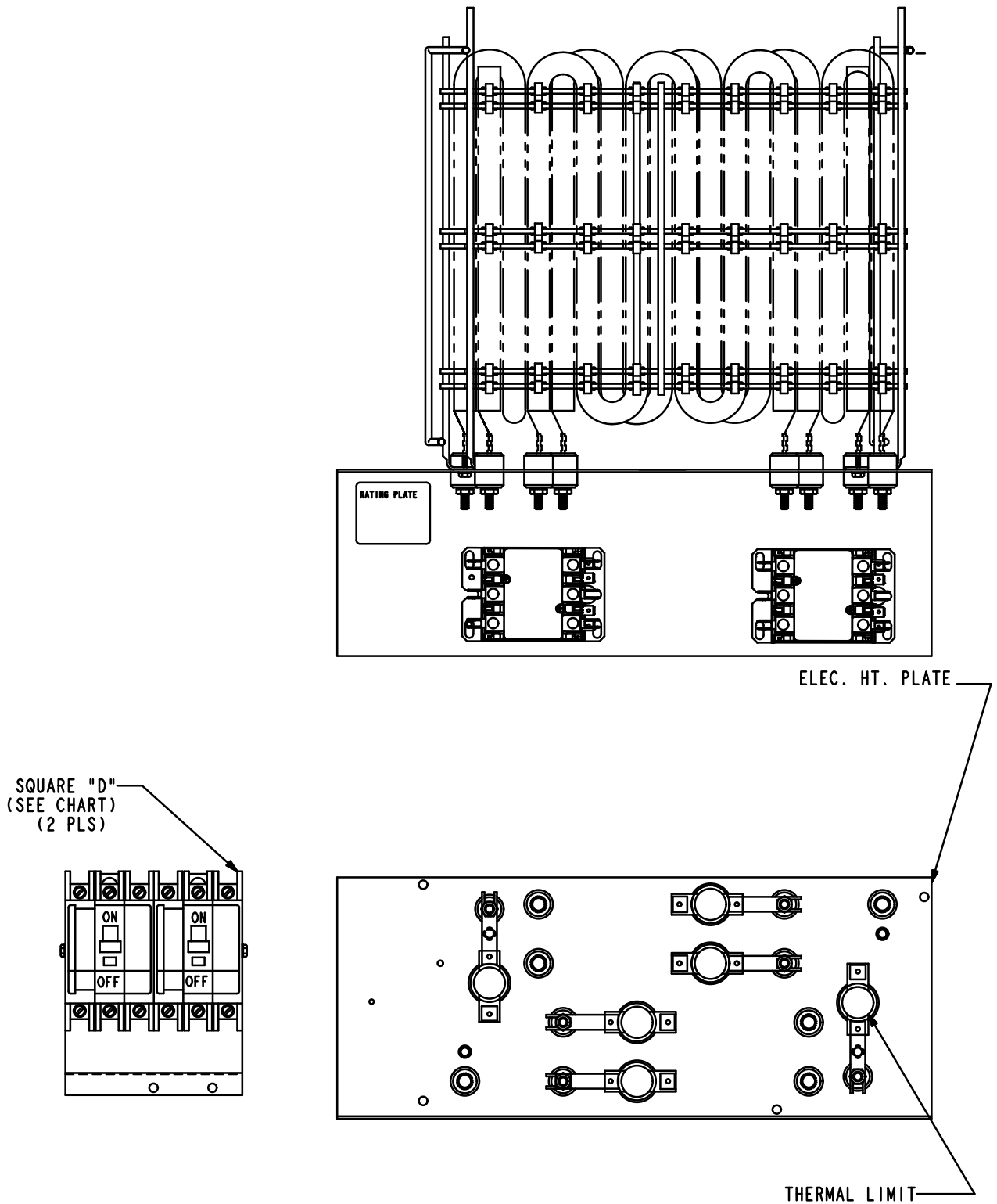

FIGURE 10

**ECB29-20CB, -25CB 208/230 THREE-PHASE  
ELECTRIC HEAT VESTIBULE PARTS ARRANGEMENT**



**FIGURE 11**

ELECTRIC HEAT DATA – CBA27UHE-018

Model Number	No. of Stages	Input			<sup>2</sup> Blower Motor Full Load Amps	<sup>3</sup> Minimum Circuit Ampacity	<sup>5</sup> Maximum Overcurrent Protection	
		Volts	kW	<sup>1</sup> Btuh				
<b>SINGLE PHASE</b>								
<b>2.5 kW</b> 4 lbs.	ECB29-2.5 <b>(2L27)</b> Terminal Block	1	208	1.9	6,400	4.1	16	20
			220	2.1	7,200	4.1	18	20
			230	2.3	7,800	4.1	18	20
			240	2.5	8,500	4.1	18	20
<b>4 kW</b> 4 lbs.	ECB29-4 <b>(2L30)</b> Terminal Block ECB29-4CB <b>(2L45)</b> 30A Circuit breaker	1	208	3.0	10,250	4.1	23	<sup>4</sup> <b>25</b>
			220	3.4	11,450	4.1	26	30
			230	3.7	12,550	4.1	26	30
			240	4.0	13,650	4.1	26	30
<b>5 kW</b> 4 lbs.	ECB29-5 <b>(2L35)</b> Terminal Block ECB29-5CB <b>(2L47)</b> 30A Circuit breaker	1	208	3.8	12,800	4.1	28	30
			220	4.2	14,300	4.1	31	<sup>4</sup> <b>35</b>
			230	4.6	15,700	4.1	31	<sup>4</sup> <b>35</b>
			240	5.0	17,100	4.1	31	<sup>4</sup> <b>35</b>
<b>6 kW</b> 4 lbs.	ECB29-6 <b>(2L44)</b> Terminal Block ECB29-6CB <b>(2L49)</b> 35A Circuit breaker	1	208	4.5	15,400	4.1	32	35
			220	5.0	17,100	4.1	36	<sup>4</sup> <b>40</b>
			230	5.5	18,800	4.1	36	<sup>4</sup> <b>40</b>
			240	6.0	20,500	4.1	36	<sup>4</sup> <b>40</b>
<b>8 kW</b> 5 lbs.	ECB29-8 <b>(2L50)</b> Terminal Block ECB29-8CB <b>(2L52)</b> 45A Circuit breaker	1	208	6.0	20,500	4.1	41	45
			220	6.7	22,900	4.1	47	<sup>4</sup> <b>50</b>
			230	7.3	25,100	4.1	47	<sup>4</sup> <b>50</b>
			240	8.0	27,300	4.1	47	<sup>4</sup> <b>50</b>
<b>9 kW</b> 5 lbs.	ECB29-9CB <b>(3T79)</b> 60A Circuit breaker	2	208	6.8	23,100	4.1	46	<sup>4</sup> <b>50</b>
			220	7.6	25,800	4.1	52	60
			230	8.3	28,200	4.1	52	60
			240	9.0	30,700	4.1	52	60
<b>10 kW</b> 6 lbs.	ECB29-10 <b>(3T83)</b> Terminal Block ECB29-10CB <b>(3T87)</b> 60A Circuit breaker	2	208	7.5	25,600	4.1	50	<sup>4</sup> <b>50</b>
			220	8.4	28,700	4.1	57	60
			230	9.2	31,400	4.1	57	60
			240	10.0	34,100	4.1	57	60

NOTE – Circuit 1 Minimum Circuit Ampacity includes the Blower Motor Full Load Amps.

<sup>1</sup> Electric heater capacity only – does not include additional blower motor heat capacity

<sup>2</sup> Amps shown are for blower motor only.

Refer to National or Canadian Electrical Code manual to determine wire, fuse and disconnect size requirements. Use wires suitable for at least 167°F

<sup>4</sup> Bold text indicates that the circuit breaker on “CB” circuit breaker models must be replaced with size noted. See table on Page 9.

<sup>5</sup> HACR type circuit breaker or fuse.

ELECTRIC HEAT DATA – CBA27UHE-024

Model Number	No. of Stages	Input			<sup>2</sup> Blower Motor Full Load Amps	<sup>3</sup> Minimum Circuit Ampacity	<sup>5</sup> Maximum Overcurrent Protection
		Volts	kW	<sup>1</sup> Btuh			
<b>SINGLE PHASE</b>							
4 kW 4 lbs. ECB29-4 (12L30) Terminal Block ECB29-4CB (12L45) 30A Circuit breaker	1	208	3.0	10,250	4.1	23	<sup>4</sup> 25
		220	3.4	11,450	4.1	26	30
		230	3.7	12,550	4.1	26	30
		240	4.0	13,650	4.1	26	30
5 kW 4 lbs. ECB29-5 (12L35) Terminal Block ECB29-5CB (12L47) 30A Circuit breaker	1	208	3.8	12,800	4.1	28	30
		220	4.2	14,300	4.1	31	<sup>4</sup> 35
		230	4.6	15,700	4.1	31	<sup>4</sup> 35
		240	5.0	17,100	4.1	31	<sup>4</sup> 35
6 kW 4 lbs. ECB29-6 (12L44) Terminal Block ECB29-6CB (12L49) 35A Circuit breaker	1	208	4.5	15,400	4.1	32	35
		220	5.0	17,100	4.1	36	<sup>4</sup> 40
		230	5.5	18,800	4.1	36	<sup>4</sup> 40
		240	6.0	20,500	4.1	36	<sup>4</sup> 40
8 kW 5 lbs. ECB29-8 (12L50) Terminal Block ECB29-8CB (12L52) 45A Circuit breaker	1	208	6.0	20,500	4.1	41	45
		220	6.7	22,900	4.1	47	<sup>4</sup> 50
		230	7.3	25,100	4.1	47	<sup>4</sup> 50
		240	8.0	27,300	4.1	47	<sup>4</sup> 50
9 kW 5 lbs. ECB29-9CB (13T79) 60A Circuit breaker	2	208	6.8	23,100	4.1	46	<sup>4</sup> 50
		220	7.6	25,800	4.1	52	60
		230	8.3	28,200	4.1	52	60
		240	9.0	30,700	4.1	52	60
10 kW 6 lbs. ECB29-10 (13T83) Terminal Block ECB29-10CB (13T87) 60A Circuit breaker	2	208	7.5	25,600	4.1	50	<sup>4</sup> 50
		220	8.4	28,700	4.1	57	60
		230	9.2	31,400	4.1	57	60
		240	10.0	34,100	4.1	57	60

NOTE – Circuit 1 Minimum Circuit Ampacity includes the Blower Motor Full Load Amps.

<sup>1</sup> Electric heater capacity only – does not include additional blower motor heat capacity

<sup>2</sup> Amps shown are for blower motor only.

Refer to National or Canadian Electrical Code manual to determine wire, fuse and disconnect size requirements. Use wires suitable for at least 167°F

<sup>4</sup> Bold text indicates that the circuit breaker on "CB" circuit breaker models must be replaced with size noted. See table on Page 9.

<sup>5</sup> HACR type circuit breaker or fuse.

ELECTRIC HEAT DATA – CBA27UHE–030

Model Number	No. of Stages	Input			<sup>2</sup> Blower Motor Full Load Amps	<sup>3</sup> Minimum Circuit Ampacity		<sup>5</sup> Maximum Overcurrent Protection		Single Point Power Source		
		Volts	kW	<sup>1</sup> Btuh		Ckt 1	Ckt 2	Ckt 1	Ckt 2	<sup>3</sup> Minimum Circuit Ampacity	<sup>5</sup> Maximum Overcurrent Protection	
<b>SINGLE PHASE</b>												
4 kW 4 lbs. ECB29-4 (12L30) Terminal Block ECB29-4CB (12L45) 30A Circuit breaker	1	208	3.0	10,250	4.1	23	---	<sup>4</sup> 25	---	---	---	
		220	3.4	11,450	4.1	26	---	30	---	---	---	
		230	3.7	12,550	4.1	26	---	30	---	---	---	
		240	4.0	13,650	4.1	26	---	30	---	---	---	
5 kW 4 lbs. ECB29-5 (12L35) Terminal Block ECB29-5CB (12L47) 30A Circuit breaker	1	208	3.8	12,800	4.1	28	---	30	---	---	---	
		220	4.2	14,300	4.1	31	---	<sup>4</sup> 35	---	---	---	
		230	4.6	15,700	4.1	31	---	<sup>4</sup> 35	---	---	---	
		240	5.0	17,100	4.1	31	---	<sup>4</sup> 35	---	---	---	
6 kW 4 lbs. ECB29-6 (12L44) Terminal Block ECB29-6CB (12L49) 35A Circuit breaker	1	208	4.5	15,400	4.1	32	---	35	---	---	---	
		220	5.0	17,100	4.1	36	---	<sup>4</sup> 40	---	---	---	
		230	5.5	18,800	4.1	36	---	<sup>4</sup> 40	---	---	---	
		240	6.0	20,500	4.1	36	---	<sup>4</sup> 40	---	---	---	
8 kW 5 lbs. ECB29-8 (12L50) Terminal Block ECB29-8CB (12L52) 45A Circuit breaker	1	208	6.0	20,500	4.1	41	---	45	---	---	---	
		220	6.7	22,900	4.1	47	---	<sup>4</sup> 50	---	---	---	
		230	7.3	25,100	4.1	47	---	<sup>4</sup> 50	---	---	---	
		240	8.0	27,300	4.1	47	---	<sup>4</sup> 50	---	---	---	
9 kW 5 lbs. ECB29-9CB (13T79) 60A Circuit breaker 60A Circuit breaker	2	208	6.8	23,100	4.1	46	---	<sup>4</sup> 50	---	---	---	
		220	7.6	25,800	4.1	52	---	60	---	---	---	
		230	8.3	28,200	4.1	52	---	60	---	---	---	
		240	9.0	30,700	4.1	52	---	60	---	---	---	
10 kW 6 lbs. ECB29-10 (13T83) Terminal Block ECB29-10CB (13T87) 60A Circuit breaker	2	208	7.5	25,600	4.1	50	---	<sup>4</sup> 50	---	---	---	
		220	8.4	28,700	4.1	57	---	60	---	---	---	
		230	9.2	31,400	4.1	57	---	60	---	---	---	
		240	10.0	34,100	4.1	57	---	60	---	---	---	
12.5 kW 10 lbs. ECB29-12.5CB (13T88) (1) 25A Circuit breaker & (1) 50A Circuit breaker	2	208	9.4	32,000	4.1	24	38	25	<sup>4</sup> 40	62	70	
		220	10.5	35,800	4.1	27	43	<sup>4</sup> 30	<sup>4</sup> 45	70	70	
		230	11.5	39,200	4.1	27	43	<sup>4</sup> 30	<sup>4</sup> 45	70	70	
		240	12.5	42,600	4.1	27	43	<sup>4</sup> 30	<sup>4</sup> 45	70	70	
15 kW 12 lbs. ECB29-15CB (13T91) (1) 30A Circuit breaker & (1) 60A Circuit Breaker	2	208	11.3	38,400	4.1	28	45	30	<sup>4</sup> 45	73	80	
		220	12.6	43,000	4.1	31	52	<sup>4</sup> 35	60	83	90	
		230	13.8	47,000	4.1	31	52	<sup>4</sup> 35	60	83	90	
		240	15.0	51,200	4.1	31	52	<sup>4</sup> 35	60	83	90	
<b>THREE PHASE</b>												
8 kW 5 lbs. ECB29-8 (12L61) Terminal Block	1	208	6.0	20,500	4.1	26	---	30	---	---	---	
		220	6.7	22,900	4.1	29	---	30	---	---	---	
		230	7.3	25,100	4.1	29	---	30	---	---	---	
		240	8.0	27,300	4.1	29	---	30	---	---	---	
10 kW 6 lbs. ECB29-10 (12L62) Terminal Block	1	208	7.5	25,600	4.1	31	---	35	---	---	---	
		220	8.4	28,700	4.1	35	---	35	---	---	---	
		230	9.2	31,400	4.1	35	---	35	---	---	---	
		240	10.0	34,100	4.1	35	---	35	---	---	---	
15 kW 12 lbs. ECB29-15CB (12L63) (1) 50A Circuit breaker	1	208	11.3	38,400	4.1	44	---	45	---	---	---	
		220	12.6	43,000	4.1	50	---	50	---	---	---	
		230	13.5	47,000	4.1	50	---	50	---	---	---	
		240	15.0	51,200	4.1	50	---	50	---	---	---	

NOTE – Circuit 1 Minimum Circuit Ampacity includes the Blower Motor Full Load Amps.

<sup>1</sup> Electric heater capacity only – does not include additional blower motor heat capacity

<sup>2</sup> Amps shown are for blower motor only.

Refer to National or Canadian Electrical Code manual to determine wire, fuse and disconnect size requirements. Use wires suitable for at least 167°F

<sup>4</sup> Bold text indicates that the circuit breaker on “CB” circuit breaker models must be replaced with size noted. See Table on Page 9.

<sup>5</sup> HACR type circuit breaker or fuse.

ELECTRIC HEAT DATA – CBA27UHE–036

Model Number	No. of Stages	Input			<sup>2</sup> Blower Motor Full Load Amps	<sup>3</sup> Minimum Circuit Ampacity		<sup>5</sup> Maximum Overcurrent Protection		Single Point Power Source		
		Volts	kW	<sup>1</sup> Btuh		Ckt 1	Ckt 2	Ckt 1	Ckt 2	<sup>3</sup> Minimum Circuit Ampacity	<sup>5</sup> Maximum Overcurrent Protection	
<b>SINGLE PHASE</b>												
<b>4 kW</b> 4 lbs.	ECB29-4 <b>(2L30)</b> Terminal Block ECB29-4CB <b>(2L45)</b> 30A Circuit breaker	1	208	3.0	10,250	4.1	23	---	<sup>4</sup> <b>25</b>	---	---	---
			220	3.4	11,450	4.1	26	---	30	---	---	---
			230	3.7	12,550	4.1	26	---	30	---	---	---
			240	4.0	13,650	4.1	26	---	30	---	---	---
<b>5 kW</b> 4 lbs.	ECB29-5 <b>(2L35)</b> Terminal Block ECB29-5CB <b>(2L47)</b> 30A Circuit breaker	1	208	3.8	12,800	4.1	28	---	30	---	---	---
			220	4.2	14,300	4.1	31	---	<sup>4</sup> <b>35</b>	---	---	---
			230	4.6	15,700	4.1	31	---	<sup>4</sup> <b>35</b>	---	---	---
			240	5.0	17,100	4.1	31	---	<sup>4</sup> <b>35</b>	---	---	---
<b>6 kW</b> 4 lbs.	ECB29-6 <b>(2L44)</b> Terminal Block ECB29-6CB <b>(2L49)</b> 35A Circuit breaker	1	208	4.5	15,400	4.1	32	---	35	---	---	---
			220	5.0	17,100	4.1	36	---	<sup>4</sup> <b>40</b>	---	---	---
			230	5.5	18,800	4.1	36	---	<sup>4</sup> <b>40</b>	---	---	---
			240	6.0	20,500	4.1	36	---	<sup>4</sup> <b>40</b>	---	---	---
<b>8 kW</b> 5 lbs.	ECB29-8 <b>(2L50)</b> Terminal Block ECB29-8CB <b>(2L52)</b> 45A Circuit breaker	1	208	6.0	20,500	4.1	41	---	45	---	---	---
			220	6.7	22,900	4.1	47	---	<sup>4</sup> <b>50</b>	---	---	---
			230	7.3	25,100	4.1	47	---	<sup>4</sup> <b>50</b>	---	---	---
			240	8.0	27,300	4.1	47	---	<sup>4</sup> <b>50</b>	---	---	---
<b>9 kW</b> 5 lbs.	ECB29-9CB <b>(3T79)</b> 60A Circuit breaker	2	208	6.8	23,100	4.1	46	---	<sup>4</sup> <b>50</b>	---	---	---
			220	7.6	25,800	4.1	52	---	<b>60</b>	---	---	---
			230	8.3	28,200	4.1	52	---	<b>60</b>	---	---	---
			240	9.0	30,700	4.1	52	---	<b>60</b>	---	---	---
<b>10 kW</b> 6 lbs.	ECB29-10 <b>(3T83)</b> Terminal Block ECB29-10CB <b>(3T87)</b> 60A Circuit breaker	2	208	7.5	25,600	4.1	50	---	<sup>4</sup> <b>50</b>	---	---	---
			220	8.4	28,700	4.1	57	---	<b>60</b>	---	---	---
			230	9.2	31,400	4.1	57	---	<b>60</b>	---	---	---
			240	10.0	34,100	4.1	57	---	<b>60</b>	---	---	---
<b>12.5 kW</b> 10 lbs.	ECB29-12.5CB <b>(3T88)</b> (1) 25A Circuit breaker and (1) 50A Circuit breaker	2	208	9.4	32,000	4.1	24	38	25	<sup>4</sup> <b>40</b>	62	70
			220	10.5	35,800	4.1	27	43	<sup>4</sup> <b>30</b>	<sup>4</sup> <b>45</b>	70	70
			230	11.5	39,200	4.1	27	43	<sup>4</sup> <b>30</b>	<sup>4</sup> <b>45</b>	70	70
			240	12.5	42,600	4.1	27	43	<sup>4</sup> <b>30</b>	<sup>4</sup> <b>45</b>	70	70
<b>15 kW</b> 12 lbs.	ECB29-15CB <b>(3T91)</b> (1) 30A Circuit breaker and (1) 60A Circuit Breaker	2	208	11.3	38,400	4.1	28	45	30	<sup>4</sup> <b>45</b>	73	80
			220	12.6	43,000	4.1	31	52	<sup>4</sup> <b>35</b>	60	83	90
			230	13.8	47,000	4.1	31	52	<sup>4</sup> <b>35</b>	60	83	90
			240	15.0	51,200	4.1	31	52	<sup>4</sup> <b>35</b>	60	83	90
<b>20 kW</b> 19 lbs.	ECB29-20CB <b>(3T92)</b> (1) 50A Circuit breaker and (1) 60A Circuit Breaker	2	208	15.0	51,200	4.1	46	50	50	<sup>4</sup> <b>50</b>	96	100
			220	16.8	57,300	4.1	52	57	<sup>4</sup> <b>60</b>	60	109	125
			230	18.4	62,700	4.1	52	57	<sup>4</sup> <b>60</b>	60	109	125
			240	20.0	68,200	4.1	52	57	<sup>4</sup> <b>60</b>	60	109	125

NOTE – Circuit 1 Minimum Circuit Ampacity includes the Blower Motor Full Load Amps.

<sup>1</sup> Electric heater capacity only – does not include additional blower motor heat capacity

<sup>2</sup> Amps shown are for blower motor only.

Refer to National or Canadian Electrical Code manual to determine wire, fuse and disconnect size requirements. Use wires suitable for at least 167°F

<sup>4</sup> Bold text indicates that the circuit breaker on “CB” circuit breaker models must be replaced with size noted. See table on Page 9.

<sup>5</sup> HACR type circuit breaker or fuse.

ELECTRIC HEAT DATA – CBA27UHE–036

Model Number	No. of Stages	Input			<sup>2</sup> Blower Motor Full Load Amps	<sup>3</sup> Minimum Circuit Ampacity		<sup>5</sup> Maximum Overcurrent Protection		Single Point Power Source		
		Volts	kW	<sup>1</sup> Btuh		Ckt 1	Ckt 2	Ckt 1	Ckt 2	<sup>3</sup> Minimum Circuit Ampacity	<sup>5</sup> Maximum Overcurrent Protection	
<b>THREE PHASE</b>												
<b>8 kW</b> 5 lbs.	ECB29–8 <b>(12L61)</b> Terminal Block	1	208	6.0	20,500	4.1	26	---	30	---	---	---
			220	6.7	22,900	4.1	29	---	30	---	---	---
			230	7.3	25,100	4.1	29	---	30	---	---	---
			240	8.0	27,300	4.1	29	---	30	---	---	---
<b>10 kW</b> 6 lbs.	ECB29–10 <b>(12L62)</b> Terminal Block	1	208	7.5	25,600	4.1	31	---	35	---	---	---
			220	8.4	28,700	4.1	35	---	35	---	---	---
			230	9.2	31,400	4.1	35	---	35	---	---	---
			240	10.0	34,100	4.1	35	---	35	---	---	---
	ECB29–10 <b>(28K47)</b> (3) 20A Fuses	1	440	8.4	28,700	2.1	16	---	20	---	---	---
			460	9.2	31,400	2.1	17	---	20	---	---	---
			480	10.0	34,100	2.1	17	---	20	---	---	---
<b>15 kW</b> 12 lbs.	ECB29–15CB <b>(12L63)</b> (1) 50A Circuit breaker	1	208	11.3	38,400	4.1	44	---	<sup>4</sup> <b>45</b>	---	---	---
			220	12.6	43,000	4.1	50	---	50	---	---	---
			230	13.5	47,000	4.1	50	---	50	---	---	---
			240	15.0	51,200	4.1	50	---	50	---	---	---
	ECB29–15 <b>(28K48)</b> (3) 25A Fuses	1	440	12.6	43,000	2.1	23	---	25	---	---	---
			460	13.5	47,000	2.1	24	---	25	---	---	---
			480	15.0	51,200	2.1	25	---	30	---	---	---
<b>20 kW</b> 19 lbs.	ECB29–20CB <b>(12L64)</b> (2) 35A Circuit breaker	2	208	15.0	51,200	4.1	31	26	35	<sup>4</sup> <b>30</b>	57	60
			220	16.8	57,300	4.1	35	30	35	<sup>4</sup> <b>30</b>	65	70
			230	18.4	62,700	4.1	35	30	35	<sup>4</sup> <b>30</b>	65	70
			240	20.0	68,200	4.1	35	30	35	<sup>4</sup> <b>30</b>	65	70

NOTE – Circuit 1 Minimum Circuit Ampacity includes the Blower Motor Full Load Amps.

<sup>1</sup> Electric heater capacity only – does not include additional blower motor heat capacity

<sup>2</sup> Amps shown are for blower motor only.

Refer to National or Canadian Electrical Code manual to determine wire, fuse and disconnect size requirements. Use wires suitable for at least 167°F

<sup>4</sup> Bold text indicates that the circuit breaker on “CB” circuit breaker models must be replaced with size noted. See Table on Page 9.

<sup>5</sup> HACR type circuit breaker or fuse.

ELECTRIC HEAT DATA – CBA27UHE-042

SINGLE PHASE

	Model Number	No. of Stages	Volts Input	kW Input	1 Btuh Input	2 Blower Motor Full Load Amps	3 Minimum Circuit Ampacity			5 Maximum Overcurrent Protection			Single Point Power Source		
							Ckt 1	Ckt 2	Ckt 3	Ckt 1	Ckt 2	Ckt 3	3 Minimum Circuit Ampacity	5 Maximum Overcurrent Protection	
4 kW 4 lbs.	ECB29-4 (1 <b>2L30</b> ) Terminal Block ECB29-4CB (1 <b>2L45</b> ) 30A Circuit breaker	1	208	3.0	10,250	7.6	28	---	---	---	30	---	---	---	---
			220	3.4	11,450	7.6	30	---	---	---	30	---	---	---	---
			230	3.7	12,550	7.6	30	---	---	---	30	---	---	---	---
			240	4.0	13,650	7.6	30	---	---	---	30	---	---	---	---
5 kW 4 lbs.	ECB29-5 (1 <b>2L35</b> ) Terminal Block ECB29-5CB (1 <b>2L47</b> ) 30A Circuit breaker	1	208	3.8	12,800	7.6	32	---	---	---	<b>4 35</b>	---	---	---	---
			220	4.2	14,300	7.6	36	---	---	---	<b>4 40</b>	---	---	---	---
			230	4.6	15,700	7.6	36	---	---	---	<b>4 40</b>	---	---	---	---
			240	5.0	17,100	7.6	36	---	---	---	<b>4 40</b>	---	---	---	---
6 kW 4 lbs.	ECB29-6 (1 <b>2L44</b> ) Terminal Block ECB29-6CB (1 <b>2L49</b> ) 35A Circuit breaker	1	208	4.5	15,400	7.6	37	---	---	---	<b>4 40</b>	---	---	---	---
			220	5.0	17,100	7.6	41	---	---	---	<b>4 45</b>	---	---	---	---
			230	5.5	18,800	7.6	41	---	---	---	<b>4 45</b>	---	---	---	---
			240	6.0	20,500	7.6	41	---	---	---	<b>4 45</b>	---	---	---	---
8 kW 5 lbs.	ECB29-8 (1 <b>2L50</b> ) Terminal Block ECB29-8CB (1 <b>2L52</b> ) 45A Circuit breaker	1	208	6.0	20,500	7.6	46	---	---	---	<b>4 50</b>	---	---	---	---
			220	6.7	22,900	7.6	51	---	---	---	<b>4 60</b>	---	---	---	---
			230	7.3	25,100	7.6	51	---	---	---	<b>4 60</b>	---	---	---	---
			240	8.0	27,300	7.6	51	---	---	---	<b>4 60</b>	---	---	---	---
9 kW 5 lbs.	ECB29-9CB (1 <b>3T79</b> ) 60A Circuit breaker 60A Circuit breaker	2	208	6.8	23,100	7.6	50	---	---	---	<b>4 50</b>	---	---	---	---
			220	7.6	25,800	7.6	56	---	---	---	60	---	---	---	---
			230	8.3	28,200	7.6	56	---	---	---	60	---	---	---	---
			240	9.0	30,700	7.6	56	---	---	---	60	---	---	---	---
12.5 kW 10 lbs.	ECB29-12.5CB (1 <b>3T88</b> ) (1) 25A Circuit breaker and (1) 50A Circuit breaker	2	208	9.4	32,000	7.6	28	38	---	<b>4 30</b>	<b>4 40</b>	---	66	80	
			220	10.5	35,800	7.6	31	43	---	<b>4 35</b>	<b>4 45</b>	---	75	80	
			230	11.5	39,200	7.6	31	43	---	<b>4 35</b>	<b>4 45</b>	---	75	80	
			240	12.5	42,600	7.6	31	43	---	<b>4 35</b>	<b>4 45</b>	---	75	80	
15 kW 12 lbs.	ECB29-15CB (1 <b>3T91</b> ) (1) 30A Circuit breaker and (1) 60A Circuit breaker	2	208	11.3	38,400	7.6	32	45	---	<b>4 35</b>	<b>4 45</b>	---	77	80	
			220	12.6	43,000	7.6	36	52	---	<b>4 40</b>	60	---	88	90	
			230	13.5	47,000	7.6	36	52	---	<b>4 40</b>	60	---	88	90	
			240	15.0	51,200	7.6	36	52	---	<b>4 40</b>	60	---	88	90	
20 kW 19 lbs.	ECB29-20CB (1 <b>3T92</b> ) (1) 50A Circuit breaker and (1) 60A Circuit breaker	2	208	15.0	51,200	7.6	50	50	---	50	<b>4 50</b>	---	100	125	
			220	16.8	57,300	7.6	56	57	---	<b>4 60</b>	60	---	114	125	
			230	18.4	62,700	7.6	56	57	---	<b>4 60</b>	60	---	114	125	
			240	20.0	68,200	7.6	56	57	---	<b>4 60</b>	60	---	114	125	
25 kW 19 lbs.	ECB29-25CB (1 <b>2L59</b> ) (3) 50A Circuit breakers	3	208	18.8	64,100	7.6	47	38	38	50	<b>4 40</b>	<b>4 40</b>	123	125	
			220	21.0	71,700	7.6	53	43	43	<b>4 60</b>	<b>4 45</b>	<b>4 45</b>	140	150	
			230	23.0	78,300	7.6	53	43	43	<b>4 60</b>	<b>4 45</b>	<b>4 45</b>	140	150	
			240	25.0	85,300	7.6	53	43	43	<b>4 60</b>	<b>4 45</b>	<b>4 45</b>	140	150	

<sup>1</sup> Electric heater capacity only – does not include additional blower motor heat capacity

<sup>2</sup> Amps shown are for blower motor only.

Refer to National or Canadian Electrical Code manual to determine wire, fuse and disconnect size requirements. Use wires suitable for at least 167°F

<sup>4</sup> Bold text indicates that the circuit breaker on "CB" circuit breaker models must be replaced with size noted. See Table on Page 9.

<sup>5</sup> HACR type circuit breaker or fuse.

ELECTRIC HEAT DATA – CBA27UHE-042

THREE PHASE

	Model Number	No. of Stages	Input			<sup>2</sup> Blower Motor Full Load Amps	<sup>3</sup> Minimum Circuit Ampacity		<sup>5</sup> Maximum Overcurrent Protection		Single Point Power Source		
			Volts	kW	<sup>1</sup> Btuh		Ckt 1	Ckt 2	Ckt 1	Ckt 2	<sup>3</sup> Minimum Circuit Ampacity	<sup>5</sup> Maximum Overcurrent Protection	
<b>8 kW</b> 5 lbs.	ECB29-8 <b>(12L61)</b> Terminal block	1	208	6.0	20,500	7.6	30	---	30	---	---	---	
			220	6.7	22,900	7.6	33	---	35	---	---	---	
			230	7.3	25,100	7.6	33	---	35	---	---	---	
			240	8.0	27,300	7.6	33	---	35	---	---	---	
<b>10 kW</b> 6 lbs.	ECB29-10 <b>(12L62)</b> Terminal Block	1	208	7.5	25,600	7.6	36	---	40	---	---	---	
			220	8.4	28,700	7.6	40	---	40	---	---	---	
			230	9.2	31,400	7.6	40	---	40	---	---	---	
			240	10.0	34,100	7.6	40	---	40	---	---	---	
	ECB29-10 <b>(28K47)</b> (3) 20A Fuses	1	440	8.4	28,700	---	---	---	---	---	---	---	
			460	9.2	31,400	---	---	---	---	---	---	---	
			480	10.0	34,100	---	---	---	---	---	---	---	
<b>15 kW</b> 12 lbs.	ECB29-15CB <b>(12L63)</b> 50A Circuit breaker	1	208	11.3	38,400	7.6	49	---	50	---	---	---	
			220	12.6	43,000	7.6	55	---	<sup>4</sup> <b>60</b>	---	---	---	
			230	13.5	47,000	7.6	55	---	<sup>4</sup> <b>60</b>	---	---	---	
			240	15.0	51,200	7.6	55	---	<sup>4</sup> <b>60</b>	---	---	---	
	ECB29-15 <b>(28K48)</b> (3) 25A Fuses	1	440	12.6	43,000	---	---	---	---	---	---	---	
			460	13.5	47,000	---	---	---	---	---	---	---	
			480	15.0	51,200	---	---	---	---	---	---	---	
<b>20 kW</b> 19 lbs.	ECB29-20CB <b>(12L64)</b> (2) 35A Circuit breaker	2	208	15.0	51,200	7.6	36	26	<sup>4</sup> <b>40</b>	<sup>4</sup> <b>30</b>	62	70	
			220	16.8	57,300	7.6	40	30	<sup>4</sup> <b>40</b>	<sup>4</sup> <b>30</b>	70	70	
			230	18.4	62,700	7.6	40	30	<sup>4</sup> <b>40</b>	<sup>4</sup> <b>30</b>	70	70	
			240	20.0	68,200	7.6	40	30	<sup>4</sup> <b>40</b>	<sup>4</sup> <b>30</b>	70	70	
	ECB29-20 <b>(28K49)</b> (3) 35A Fuses	1	440	16.8	57,300	---	---	---	---	---	---	---	
			460	18.4	62,700	---	---	---	---	---	---	---	
			480	20.0	68,200	---	---	---	---	---	---	---	
	<sup>6</sup> ECB29-20 <b>(28K51)</b> (3) 25A Fuses	1	550	16.8	57,300	---	---	---	---	---	---	---	
			575	18.4	62,700	---	---	---	---	---	---	---	
			600	20.0	68,200	---	---	---	---	---	---	---	
	<b>25 kW</b> 19 lbs.	ECB29-25CB <b>(12L65)</b> (2) 45A Circuit breaker	2	208	18.8	64,100	7.6	42	33	<sup>4</sup> <b>50</b>	<sup>4</sup> <b>35</b>	62	70
				220	21.0	71,700	7.6	47	38	<sup>4</sup> <b>50</b>	<sup>4</sup> <b>40</b>	85	90
230				23.0	78,300	7.6	47	38	<sup>4</sup> <b>50</b>	<sup>4</sup> <b>40</b>	85	90	
240				25.0	85,300	7.6	47	38	<sup>4</sup> <b>50</b>	<sup>4</sup> <b>40</b>	85	90	
ECB29-25 <b>(28K50)</b> (3) 40A Fuses		1	440	21.0	71,700	---	---	---	---	---	---	---	
			460	23.0	78,300	---	---	---	---	---	---	---	
			480	25.0	85,300	---	---	---	---	---	---	---	
<sup>6</sup> ECB29-25 <b>(28K52)</b> (3) 35A Fuses		1	550	21.0	71,700	---	---	---	---	---	---	---	
			575	23.0	78,300	---	---	---	---	---	---	---	
			600	25.0	85,300	---	---	---	---	---	---	---	

NOTE – Circuit 1 Minimum Circuit Ampacity includes the Blower Motor Full Load Amps.

<sup>1</sup> Electric heater capacity only – does not include additional blower motor heat capacity

<sup>2</sup> Amps shown are for blower motor only.

Refer to National or Canadian Electrical Code manual to determine wire, fuse and disconnect size requirements. Use wires suitable for at least 167°F

<sup>4</sup> Bold text indicates that the circuit breaker on "CB" circuit breaker models must be replaced with size noted. See table on Page 9.

<sup>5</sup> HACR type circuit breaker or fuse.

ELECTRIC HEAT DATA – CBA27UHE–048

SINGLE PHASE

Model Number	No. of Stages	Input			<sup>2</sup> Blower Motor Full Load Amps	<sup>3</sup> Minimum Circuit Ampacity			<sup>5</sup> Maximum Overcurrent Protection			Single Point Power Source	
		Volts	kW	<sup>1</sup> Btuh		Ckt 1	Ckt 2	Ckt 3	Ckt 1	Ckt 2	Ckt 3	<sup>3</sup> Minimum Circuit Ampacity	<sup>5</sup> Maximum Overcurrent Protection
4 kW 4 lbs. ECB29-4 (2L30) Terminal Block ECB29-4CB (2L45) 30A Circuit breaker	1	208	3.0	10,250	7.6	28	---	---	30	---	---	---	---
		220	3.4	11,450	7.6	30	---	---	30	---	---	---	---
		230	3.7	12,550	7.6	30	---	---	30	---	---	---	---
		240	4.0	13,650	7.6	30	---	---	30	---	---	---	---
5 kW 4 lbs. ECB29-5 (2L35) Terminal Block ECB29-5CB (2L47) 30A Circuit breaker	1	208	3.8	12,800	7.6	32	---	---	<sup>4</sup> 35	---	---	---	---
		220	4.2	14,300	7.6	36	---	---	<sup>4</sup> 40	---	---	---	---
		230	4.6	15,700	7.6	36	---	---	<sup>4</sup> 40	---	---	---	---
		240	5.0	17,100	7.6	36	---	---	<sup>4</sup> 40	---	---	---	---
6 kW 4 lbs. ECB29-6 (2L44) Terminal Block ECB29-6CB (2L49) 35A Circuit breaker	1	208	4.5	15,400	7.6	37	---	---	<sup>4</sup> 40	---	---	---	---
		220	5.0	17,100	7.6	41	---	---	<sup>4</sup> 45	---	---	---	---
		230	5.5	18,800	7.6	41	---	---	<sup>4</sup> 45	---	---	---	---
		240	6.0	20,500	7.6	41	---	---	<sup>4</sup> 45	---	---	---	---
8 kW 5 lbs. ECB29-8 (2L50) Terminal Block ECB29-8CB (2L52) 45A Circuit breaker	1	208	6.0	20,500	7.6	46	---	---	<sup>4</sup> 50	---	---	---	---
		220	6.7	22,900	7.6	51	---	---	<sup>4</sup> 60	---	---	---	---
		230	7.3	25,100	7.6	51	---	---	<sup>4</sup> 60	---	---	---	---
		240	8.0	27,300	7.6	51	---	---	<sup>4</sup> 60	---	---	---	---
9 kW 5 lbs. ECB29-9CB (3T79) 60A Circuit breaker	2	208	6.8	23,100	7.6	50	---	---	<sup>4</sup> 50	---	---	---	---
		220	7.6	25,800	7.6	56	---	---	60	---	---	---	---
		230	8.3	28,200	7.6	56	---	---	60	---	---	---	---
		240	9.0	30,700	7.6	56	---	---	60	---	---	---	---
12.5 kW 10 lbs. ECB29-12.5CB (3T88) (1) 25A Circuit breaker & (1) 50A Circuit breaker	2	208	9.4	32,000	7.6	28	38	---	<sup>4</sup> 30	<sup>4</sup> 40	---	66	80
		220	10.5	35,800	7.6	31	43	---	<sup>4</sup> 35	<sup>4</sup> 45	---	75	80
		230	11.5	39,200	7.6	31	43	---	<sup>4</sup> 35	<sup>4</sup> 45	---	75	80
		240	12.5	42,600	7.6	31	43	---	<sup>4</sup> 35	<sup>4</sup> 45	---	75	80
15 kW 12 lbs. ECB29-15CB (3T91) (1) 30A Circuit breaker & (1) 60A Circuit breaker	2	208	11.3	38,400	7.6	32	45	---	<sup>4</sup> 35	<sup>4</sup> 45	---	77	80
		220	12.6	43,000	7.6	36	52	---	<sup>4</sup> 40	60	---	88	90
		230	13.5	47,000	7.6	36	52	---	<sup>4</sup> 40	60	---	88	90
		240	15.0	51,200	7.6	36	52	---	<sup>4</sup> 40	60	---	88	90
20 kW 19 lbs. ECB29-20CB (3T92) (1) 50A Circuit breaker & (1) 60A Circuit breaker	2	208	15.0	51,200	7.6	50	50	---	50	<sup>4</sup> 50	---	100	125
		220	16.8	57,300	7.6	56	57	---	<sup>4</sup> 60	60	---	114	125
		230	18.4	62,700	7.6	56	57	---	<sup>4</sup> 60	60	---	114	125
		240	20.0	68,200	7.6	56	57	---	<sup>4</sup> 60	60	---	114	125
25 kW 19 lbs. ECB29-25CB (2L59) (3) 50A Circuit breakers	3	208	18.8	64,100	7.6	47	38	38	50	<sup>4</sup> 40	<sup>4</sup> 40	123	125
		220	21.0	71,700	7.6	53	43	43	<sup>4</sup> 60	<sup>4</sup> 45	<sup>4</sup> 45	140	150
		230	23.0	78,300	7.6	53	43	43	<sup>4</sup> 60	<sup>4</sup> 45	<sup>4</sup> 45	140	150
		240	25.0	85,300	7.6	53	43	43	<sup>4</sup> 60	<sup>4</sup> 45	<sup>4</sup> 45	140	150

NOTE – Circuit 1 Minimum Circuit Ampacity includes the Blower Motor Full Load Amps.

<sup>1</sup> Electric heater capacity only – does not include additional blower motor heat capacity

<sup>2</sup> Amps shown are for blower motor only.

Refer to National or Canadian Electrical Code manual to determine wire, fuse and disconnect size requirements. Use wires suitable for at least 167°F

<sup>4</sup> Bold text indicates that the circuit breaker on “CB” circuit breaker models must be replaced with size noted. See table on Page 9.

<sup>5</sup> HACR type circuit breaker or fuse.

ELECTRIC HEAT DATA – CBA27UHE-048

THREE PHASE

	Model Number	No. of Stages	Input			<sup>2</sup> Blower Motor Full Load Amps	<sup>3</sup> Minimum Circuit Ampacity		<sup>5</sup> Maximum Overcurrent Protection		Single Point Power Source		
			Volts	kW	<sup>1</sup> Btuh		Ckt 1	Ckt 2	Ckt 1	Ckt 2	<sup>3</sup> Minimum Circuit Ampacity	<sup>5</sup> Maximum Overcurrent Protection	
<b>8 kW</b> 5 lbs.	ECB29-8 <b>(12L61)</b> Terminal block	1	208	6.0	20,500	7.6	30	---	30	---	---	---	
			220	6.7	22,900	7.6	33	---	35	---	---	---	
			230	7.3	25,100	7.6	33	---	35	---	---	---	
			240	8.0	27,300	7.6	33	---	35	---	---	---	
<b>10 kW</b> 6 lbs.	ECB29-10 <b>(12L62)</b> Terminal Block	1	208	7.5	25,600	7.6	36	---	40	---	---	---	
			220	8.4	28,700	7.6	40	---	40	---	---	---	
			230	9.2	31,400	7.6	40	---	40	---	---	---	
			240	10.0	34,100	7.6	40	---	40	---	---	---	
	ECB29-10 <b>(28K47)</b> (3) 20A Fuses	1	440	8.4	28,700	4.0	18	---	20	---	---	---	
			460	9.2	31,400	4.0	19	---	20	---	---	---	
			480	10.0	34,100	4.0	20	---	25	---	---	---	
<b>15 kW</b> 12 lbs.	ECB29-15CB <b>(12L63)</b> 50A Circuit breaker	1	208	11.3	38,400	7.6	49	---	50	---	---	---	
			220	12.6	43,000	7.6	55	---	<b>4 60</b>	---	---	---	
			230	13.5	47,000	7.6	55	---	<b>4 60</b>	---	---	---	
			240	15.0	51,200	7.6	55	---	<b>4 60</b>	---	---	---	
	ECB29-15 <b>(28K48)</b> (3) 25A Fuses	1	440	12.6	43,000	4.0	25	---	30	---	---	---	
			460	13.5	47,000	4.0	26	---	30	---	---	---	
			480	15.0	51,200	4.0	27	---	30	---	---	---	
<b>20 kW</b> 19 lbs.	ECB29-20CB <b>(12L64)</b> (2) 35A Circuit breaker	2	208	15.0	51,200	7.6	36	26	<b>4 40</b>	<b>4 30</b>	62	70	
			220	16.8	57,300	7.6	40	30	<b>4 40</b>	<b>4 30</b>	70	70	
			230	18.4	62,700	7.6	40	30	<b>4 40</b>	<b>4 30</b>	70	70	
			240	20.0	68,200	7.6	40	30	<b>4 40</b>	<b>4 30</b>	70	70	
	ECB29-20 <b>(28K49)</b> (3) 35A Fuses	1	440	16.8	57,300	4.0	33	---	35	---	---	---	
			460	18.4	62,700	4.0	34	---	35	---	---	---	
			480	20.0	68,200	4.0	35	---	40	---	---	---	
	<sup>6</sup> ECB29-20 <b>(28K51)</b> (3) 25A Fuses	1	550	16.8	57,300	4.0	27	---	30	---	---	---	
			575	18.4	62,700	4.0	28	---	30	---	---	---	
			600	20.0	68,200	4.0	29	---	30	---	---	---	
	<b>25 kW</b> 19 lbs.	ECB29-25CB <b>(12L65)</b> (2) 45A Circuit breaker	2	208	18.8	64,100	7.6	42	33	<b>4 50</b>	<b>4 35</b>	75	80
				220	21.0	71,700	7.6	47	38	<b>4 50</b>	<b>4 40</b>	85	90
230				23.0	78,300	7.6	47	38	<b>4 50</b>	<b>4 40</b>	85	90	
240				25.0	85,300	7.6	47	38	<b>4 50</b>	<b>4 40</b>	85	90	
ECB29-25 <b>(28K50)</b> (3) 40A Fuses		1	440	21.0	71,700	4.0	39	---	40	---	---	---	
			460	23.0	78,300	4.0	41	---	45	---	---	---	
			480	25.0	85,300	4.0	42	---	45	---	---	---	
<sup>6</sup> ECB29-25 <b>(28K52)</b> (3) 35A Fuses		1	550	21.0	71,700	4.0	32	---	35	---	---	---	
			575	23.0	78,300	4.0	34	---	35	---	---	---	
			600	25.0	85,300	4.0	35	---	40	---	---	---	

NOTE – Circuit 1 Minimum Circuit Ampacity includes the Blower Motor Full Load Amps.

<sup>1</sup> Electric heater capacity only – does not include additional blower motor heat capacity

<sup>2</sup> Amps shown are for blower motor only.

Refer to National or Canadian Electrical Code manual to determine wire, fuse and disconnect size requirements. Use wires suitable for at least 167°F

<sup>4</sup> Bold text indicates that the circuit breaker on “CB” circuit breaker models must be replaced with size noted. See table on Page 9.

<sup>5</sup> HACR type circuit breaker or fuse.

ELECTRIC HEAT DATA – CBA27UHE-060

SINGLE PHASE

Model Number	No. of Stages	Input			<sup>2</sup> Blower Motor Full Load Amps	<sup>3</sup> Minimum Circuit Ampacity			<sup>5</sup> Maximum Overcurrent Protection			Single Point Power Source	
		Volts	kW	<sup>1</sup> Btuh		Ckt 1	Ckt 2	Ckt 3	Ckt 1	Ckt 2	Ckt 3	<sup>3</sup> Minimum Circuit Ampacity	<sup>5</sup> Maximum Overcurrent Protection
4 kW 4 lbs. ECB29-4 (12L30) Terminal Block ECB29-4CB (12L45) 30A Circuit breaker	1	208	3.0	10,250	7.6	28	---	---	30	---	---	---	---
		220	3.4	11,450	7.6	30	---	---	30	---	---	---	---
		230	3.7	12,550	7.6	30	---	---	30	---	---	---	---
		240	4.0	13,650	7.6	30	---	---	30	---	---	---	---
5 kW 4 lbs. ECB29-5 (12L35) Terminal Block ECB29-5CB (12L47) 30A Circuit breaker	1	208	3.8	12,800	7.6	32	---	---	<sup>4</sup> 35	---	---	---	---
		220	4.2	14,300	7.6	36	---	---	<sup>4</sup> 40	---	---	---	---
		230	4.6	15,700	7.6	36	---	---	<sup>4</sup> 40	---	---	---	---
		240	5.0	17,100	7.6	36	---	---	<sup>4</sup> 40	---	---	---	---
6 kW 4 lbs. ECB29-6 (12L44) Terminal Block ECB29-6CB (12L49) 35A Circuit breaker	1	208	4.5	15,400	7.6	37	---	---	<sup>4</sup> 40	---	---	---	---
		220	5.0	17,100	7.6	41	---	---	<sup>4</sup> 45	---	---	---	---
		230	5.5	18,800	7.6	41	---	---	<sup>4</sup> 45	---	---	---	---
		240	6.0	20,500	7.6	41	---	---	<sup>4</sup> 45	---	---	---	---
8 kW 5 lbs. ECB29-8 (12L50) Terminal Block ECB29-8CB (12L52) 45A Circuit breaker	1	208	6.0	20,500	7.6	46	---	---	<sup>4</sup> 50	---	---	---	---
		220	6.7	22,900	7.6	51	---	---	<sup>4</sup> 60	---	---	---	---
		230	7.3	25,100	7.6	51	---	---	<sup>4</sup> 60	---	---	---	---
		240	8.0	27,300	7.6	51	---	---	<sup>4</sup> 60	---	---	---	---
9 kW 5 lbs. ECB29-9CB (13T79) 60A Circuit breaker	2	208	6.8	23,100	7.6	50	---	---	<sup>4</sup> 50	---	---	---	---
		220	7.6	25,800	7.6	56	---	---	60	---	---	---	---
		230	8.3	28,200	7.6	56	---	---	60	---	---	---	---
		240	9.0	30,700	7.6	56	---	---	60	---	---	---	---
12.5 kW 10 lbs. ECB29-12.5CB (13T88) (1) 25A Circuit Breaker and (1) 50A Circuit breaker	2	208	9.4	32,000	7.6	28	38	---	<sup>4</sup> 30	<sup>4</sup> 40	---	66	70
		220	10.5	35,800	7.6	31	43	---	<sup>4</sup> 35	<sup>4</sup> 45	---	75	80
		230	11.5	39,200	7.6	31	43	---	<sup>4</sup> 35	<sup>4</sup> 45	---	75	80
		240	12.5	42,600	7.6	31	43	---	<sup>4</sup> 35	<sup>4</sup> 45	---	75	80
15 kW 12 lbs. ECB29-15CB (13T91) (1) 30A Circuit breaker and (1) 60A Circuit breaker	2	208	11.3	38,400	7.6	32	45	---	<sup>4</sup> 35	<sup>4</sup> 45	---	77	80
		220	12.6	43,000	7.6	36	52	---	<sup>4</sup> 40	60	---	88	90
		230	13.5	47,000	7.6	36	52	---	<sup>4</sup> 40	60	---	88	90
		240	15.0	51,200	7.6	36	52	---	<sup>4</sup> 40	60	---	88	90
20 kW 19 lbs. ECB29-20CB (13T92) (1) 50A Circuit Breaker and (1) 60A Circuit breaker	2	208	15.0	51,200	7.6	50	50	---	50	<sup>4</sup> 50	---	100	125
		220	16.8	57,300	7.6	56	57	---	<sup>4</sup> 60	60	---	114	125
		230	18.4	62,700	7.6	56	57	---	<sup>4</sup> 60	60	---	114	125
		240	20.0	68,200	7.6	56	57	---	<sup>4</sup> 60	60	---	114	125
25 kW 19 lbs. ECB29-25CB (12L59) (3) 50A Circuit breakers	3	208	18.8	64,100	7.6	47	38	38	50	<sup>4</sup> 40	<sup>4</sup> 40	123	125
		220	21.0	71,700	7.6	53	43	43	<sup>4</sup> 60	<sup>4</sup> 45	<sup>4</sup> 45	140	150
		230	23.0	78,300	7.6	53	43	43	<sup>4</sup> 60	<sup>4</sup> 45	<sup>4</sup> 45	140	150
		240	25.0	85,300	7.6	53	43	43	<sup>4</sup> 60	<sup>4</sup> 45	<sup>4</sup> 45	140	150

NOTE – Circuit 1 Minimum Circuit Ampacity includes the Blower Motor Full Load Amps.

<sup>1</sup> Electric heater capacity only – does not include additional blower motor heat capacity

<sup>2</sup> Amps shown are for blower motor only.

Refer to National or Canadian Electrical Code manual to determine wire, fuse and disconnect size requirements. Use wires suitable for at least 167°F

<sup>4</sup> Bold text indicates that the circuit breaker on "CB" circuit breaker models must be replaced with size noted. See table on Page9.

<sup>5</sup> HACR type circuit breaker or fuse.

ELECTRIC HEAT DATA – CBA27UHE-060

THREE PHASE

	Model Number	No. of Stages	Input			<sup>2</sup> Blower Motor Full Load Amps	<sup>3</sup> Minimum Circuit Ampacity		<sup>5</sup> Maximum Overcurrent Protection		Single Point Power Source	
			Volts	kW	<sup>1</sup> Btuh		Ckt 1	Ckt 2	Ckt 1	Ckt 2	<sup>3</sup> Minimum Circuit Ampacity	<sup>5</sup> Maximum Overcurrent Protection
<b>8 kW</b> 5 lbs.	ECB29-8 <b>(12L61)</b> Terminal block	1	208	6.0	20,500	7.6	30	---	30	---	---	---
			220	6.7	22,900	7.6	33	---	35	---	---	---
			230	7.3	25,100	7.6	33	---	35	---	---	---
			240	8.0	27,300	7.6	33	---	35	---	---	---
<b>10 kW</b> 6 lbs.	ECB29-10 <b>(12L62)</b> Terminal Block	1	208	7.5	25,600	7.6	36	---	40	---	---	---
			220	8.4	28,700	7.6	40	---	40	---	---	---
			230	9.2	31,400	7.6	40	---	40	---	---	---
			240	10.0	34,100	7.6	40	---	40	---	---	---
	ECB29-10 <b>(28K47)</b> (3) 20A Fuses	1	440	8.4	28,700	4.0	18	---	20	---	---	---
			460	9.2	31,400	4.0	19	---	20	---	---	---
			480	10.0	34,100	4.0	20	---	25	---	---	---
<b>15 kW</b> 12 lbs.	ECB29-15CB <b>(12L63)</b> 50A Circuit breaker	1	208	11.3	38,400	7.6	49	---	50	---	---	---
			220	12.6	43,000	7.6	55	---	<sup>4</sup> 60	---	---	---
			230	13.5	47,000	7.6	55	---	<sup>4</sup> 60	---	---	---
			240	15.0	51,200	7.6	55	---	<sup>4</sup> 60	---	---	---
	ECB29-15 <b>(28K48)</b> (3) 25A Fuses	1	440	12.6	43,000	4.0	25	---	30	---	---	---
			460	13.5	47,000	4.0	26	---	30	---	---	---
<b>20 kW</b> 19 lbs.	ECB29-20CB <b>(12L64)</b> (2) 35A Circuit breaker	2	208	15.0	51,200	7.6	36	26	<sup>4</sup> 40	<sup>4</sup> 30	62	70
			220	16.8	57,300	7.6	40	30	<sup>4</sup> 40	<sup>4</sup> 30	70	70
			230	18.4	62,700	7.6	40	30	<sup>4</sup> 40	<sup>4</sup> 30	70	70
			240	20.0	68,200	7.6	40	30	<sup>4</sup> 40	<sup>4</sup> 30	70	70
	ECB29-20 <b>(28K49)</b> (3) 35A Fuses	1	440	16.8	57,300	4.0	33	---	35	---	---	---
			460	18.4	62,700	4.0	34	---	35	---	---	---
			480	20.0	68,200	4.0	35	---	40	---	---	---
	<sup>6</sup> ECB29-20 <b>(28K51)</b> (3) 25A Fuses	1	550	16.8	57,300	4.0	27	---	30	---	---	---
			575	18.4	62,700	4.0	28	---	30	---	---	---
			600	20.0	68,200	4.0	29	---	30	---	---	---
<b>25 kW</b> 19 lbs.	ECB29-25CB <b>(12L65)</b> (2) 45A Circuit breaker	2	208	18.8	64,100	7.6	42	33	45	<sup>4</sup> 35	75	80
			220	21.0	71,700	7.6	47	38	<sup>4</sup> 50	<sup>4</sup> 40	85	90
			230	23.0	78,300	7.6	47	38	<sup>4</sup> 50	<sup>4</sup> 40	85	90
			240	25.0	85,300	7.6	47	38	<sup>4</sup> 50	<sup>4</sup> 40	85	90
	ECB29-25 <b>(28K50)</b> (3) 40A Fuses	1	440	21.0	71,700	4.0	39	---	40	---	---	---
			460	23.0	78,300	4.0	41	---	45	---	---	---
			480	25.0	85,300	4.0	42	---	45	---	---	---
	<sup>6</sup> ECB29-25 <b>(28K52)</b> (3) 35A Fuses	1	550	21.0	71,700	4.0	32	---	35	---	---	---
			575	23.0	78,300	4.0	34	---	35	---	---	---
			600	25.0	85,300	4.0	35	---	40	---	---	---

NOTE – Circuit 1 Minimum Circuit Ampacity includes the Blower Motor Full Load Amps.

<sup>1</sup> Electric heater capacity only – does not include additional blower motor heat capacity

<sup>2</sup> Amps shown are for blower motor only.

Refer to National or Canadian Electrical Code manual to determine wire, fuse and disconnect size requirements. Use wires suitable for at least 167°F

<sup>4</sup> Bold text indicates that the circuit breaker on "CB" circuit breaker models must be replaced with size noted. See Table on Page 9.

<sup>5</sup> HACR type circuit breaker or fuse.

## IV-START-UP - OPERATION

### A-Preliminary and Seasonal Checks

- 1- Make sure the unit is installed in accordance with the installation instructions.
- 2- Inspect electrical wiring, both field and factory installed for loose connections. Tighten as required.
- 3- Check voltage at disconnect switch. Voltage must be within range listed on the nameplate. If not, consult the power company and have voltage condition corrected before starting unit.
- 4- Check to ensure that refrigerant lines are in good condition and pipe insulation is intact.
- 5- Inspect condition of condensate drain pan and piping assembly. Disassemble and clean seasonally.

### B-Cooling Start-Up

**NOTE-** The following is a generalized procedure and does not apply to all thermostat control systems. Electronic thermostat control systems may operate differently.

- 1- Set fan switch to AUTO or ON and move the system selection switch to COOL. Adjust the thermostat to a setting far enough below room temperature to bring on the compressor. Compressor will start and cycle on demand from the thermostat.
- 2- The refrigerant circuit is charged with HFC-410A refrigerant. See outdoor unit rating plate for correct charge amount.
- 3- Refer to the correct outdoor unit service manual for more information.

### C-Heating Start-Up

- 1- Set the fan switch to AUTO or ON and move the system selection switch to HEAT. Adjust the thermostat setting above room temperature.
- 2- The indoor blower immediately starts and the electric heat will stage on based on sequencer timing.

### D-Safety or Emergency Shutdown

Turn off unit power at circuit breaker.

### E-Extended Period Shutdown

Turn off thermostat or set to "UNOCCUPIED" mode. Turn off power to unit. All access panels and covers must be in place and secured. The condensate assembly should be clean and dry for extended period shutdown.

## V-TYPICAL OPERATING CHARACTERISTICS

### A-Blower Operation and Adjustment

**NOTE-** The following is a generalized procedure and does not apply to all thermostat controls.

- 1- Blower operation is dependent on thermostat control system.
- 2- Generally, blower operation is set at thermostat sub-base fan switch. With fan switch in ON position, blower operates continuously. With fan switch in AUTO position, blower cycles with demand.

- 3- In all cases, blower and entire unit will be off when the system switch is in OFF position.

### B-External Static Pressure

- 1- Measure tap locations as shown in figure 12.

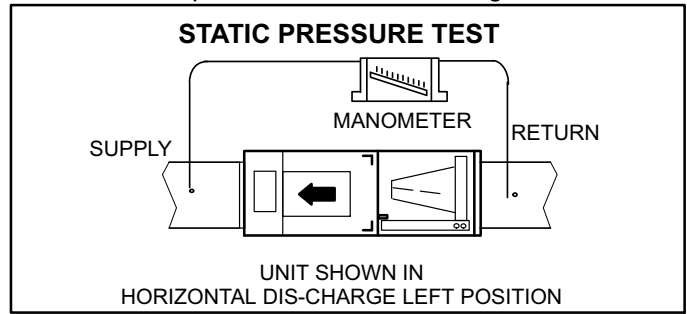

**FIGURE 12**

- 2- Punch a 1/4" (6mm) diameter hole in supply and return air plenums. Insert manometer hose flush with inside edge of hole or insulation. Seal around the hose with Permagum. Connect the zero end of the manometer to the discharge (supply) side of the system. On ducted systems, connect the other end of manometer to the return duct as above. For systems with non-ducted returns, leave the other end of the manometer open to the atmosphere.
- 3- With only the blower motor running and the evaporator coil dry, observe the manometer reading. Adjust blower motor speed to deliver the air desired according to the installation requirements.
- 4- External static pressure drop must not exceed 0.8" W.C.
- 5- Seal around the hole when the check is complete.

### C-Blower Speed Taps

#### Motor Speed Taps

**NOTE -** Motor is programmed for a 45-second delay off on all speed taps except TAP #1 (continuous fan speed).

**TABLE 1**

Tap	Operation	Remarks
1	Continuous or low speed fan (for 2-speed heat pumps or A/C units)	Continuous fan speed is energized (24 volt input to "G") when either "G" or "Y1" has a 24 volt signal (24 volt input from "Y1" passes through the room thermostat's "Fan Automatic contacts" to the "G" terminal).
2	Low-speed operation on high static system	CFM set at 1/2 ton less than nominal of unit (e.g. 3-ton set at 1000 CFM).
3	Cooling speed setting	CFM set at 400 cfm per nominal ton at ARI minimum static allowed, as follows: 1.5 to 2.0 ton - 0.10 2.5 to 3.5 ton - 0.15 4 to 5 ton - 0.20.
4	Heat pump with electric heat	CFM set at 400 cfm per nominal ton at .4 static. Energized when electric heat element has a call for heat.
5	High static applications	CFM set at 400 cfm per nominal ton at .8 static.

Table 2 shows the recommended factory blower speed tap selections for CBA27UHE series units.

These settings are for nominal tonnage match-ups with the CBA27UHE units. When matched with other sizes, it is recommended that the CFM be adjusted to approximately 400 CFM per ton.

To change blower motor speed tap remove the speed tap from Y2 on the terminal strip and insert the desired speed tap. See blower data on pages 4 and 5 for the desired CFM setting

**TABLE 2**

Recommended Blower Speed Tap Selection			
Operation	CBA27UHE	Outdoor unit	Tap
Cooling	ALL MODELS	Condensing unit	3
		Heat pump	3
Heating*		Condensing unit with electric heat only	4
		Heat pump with electric heat	4

\* Minimum setting for heat

**NOTE** - Motor is programmed for a 45-second delay off on all speed taps except TAP #1 (continuous fan speed).

**VI-MAINTENANCE**

<b>NOTICE !</b>
<p>Failure to follow instructions will cause damage to the unit.</p> <p>This unit is equipped with an aluminum coil. Aluminum coils may be damaged by exposure to solutions with a pH below 5 or above 9. The aluminum coil should be cleaned using potable water at a moderate pressure (less than 50psi). If the coil cannot be cleaned using water alone, Lennox recommends use of a coil cleaner with a pH in the range of 5 to 9. The coil must be rinsed thoroughly after cleaning.</p> <p>In coastal areas, the coil should be cleaned with potable water several times per year to avoid corrosive buildup (salt).</p>

<b>⚠ WARNING</b>
<p><b>Disconnect power before performing any maintenance.</b></p>

At the beginning of each heating / cooling season, the system should be checked as follows:

**A-Filters**

<b>⚠ IMPORTANT</b>
<p><b>Filter access panel must be in place during unit operation. Excessive warm air entering the unit may result in water blow-off problems.</b></p>

Filters may be duct-mounted or installed in the cabinet. A filter is installed at the factory. Note that filter access door fits over access panel. Air will leak if the access panel is placed over the filter door.

Filters should be inspected monthly and must be cleaned or replaced when dirty to assure proper air handler operation.

Units are equipped with standard throw-away type filters which should be replaced when dirty.

To remove filter, loosen the thumbscrews holding the filter panel in place. Slide filter out of the guides on either side of cabinet, insert new filter and replace panel.

**TABLE 3**

CBA27UHE Model	Filter Size - In. (mm)
-018, -024, -030, -036	20 x 20 (508 x 508)
-042, -048, -060	20 x 24 (508 x 610)

**B-Supply Air Blower**

- 1- Check and clean blower wheel.
- 2- Motors are pre-lubricated for extended life; no further lubrication is required.

**C-Electrical**

- 1- Check all wiring for loose connections.
- 2- Check circuit breaker located in unit control box.
- 3- Check for correct voltage at unit (unit operating).
- 4- Check amp-draw on blower motor.
- 5- Check to see that heat (if applicable) is operating.

**D-CONSTANT TORQUE SPEED BLOWER MOTOR (ECM) (B3)**

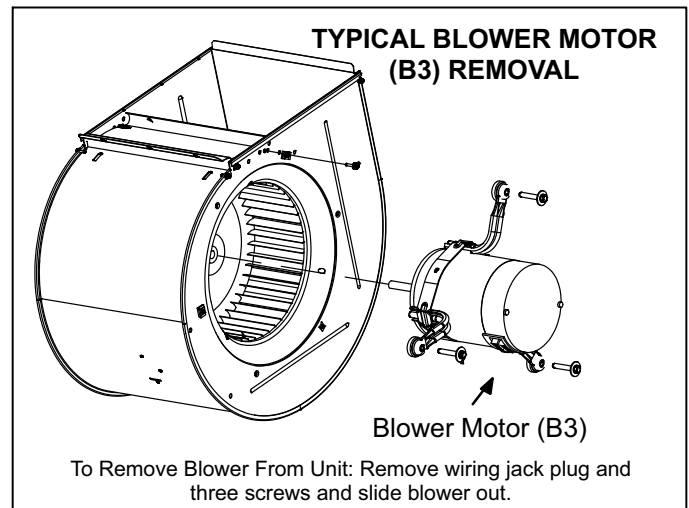

**FIGURE 13**

The constant torque ECM (electronically commutated motor) communicates with the air handler control via 24VAC inputs. It is programmed to provide a constant level of torque (current / power) to the motor. This is a multi-tap motor with the ability to have 1 to 5 programmed levels of torque (see table 4). Each value equals a specific amount of torque to create the proper amount of airflow for each system demand. This value is specific to model and size system.

**TABLE 4**

TAP SETTINGS					
Parameter	Tap 1	Tap 2	Tap 3	Tap 4	Tap 5
OFF-Delay	0	45	45	45	45
Torque (oz. ft) (Se)	25.73	37.96	47.38	50.51	57.73
% of full output	32.16	47.45	59.22	63.14	72.16

Each tap can have a unique amount of torque programmed for a specific purpose. For example, switching from Tap 1 to Tap 2 may increase the airflow, but not necessarily at a specific interval like changing from low to medium low speed on a PSC motor.

Internal components are shown in figure 14. The stator windings are split into three poles which are electrically connected to the controller. This arrangement allows motor windings to turn on and off in sequence by the controller.

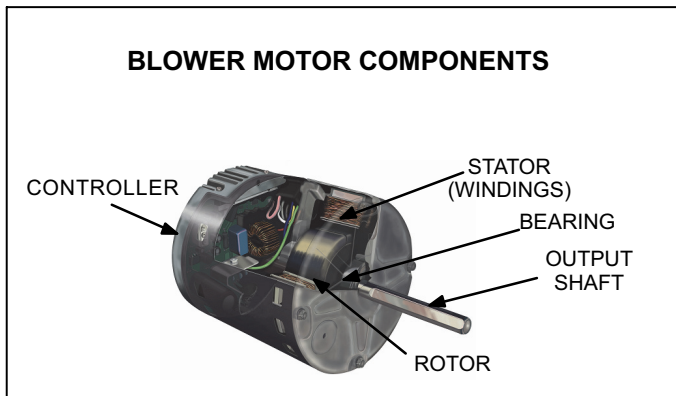

**FIGURE 14.**

The controller uses sensing devices to sense what position the rotor is in at any given time. By sensing the position of the rotor and then switching the motor windings on and off in sequence, the rotor shaft turns the blower.

**Operation**

The 230VAC voltage connections to the motor are labeled **L**, **G** and **N**.

- 230VAC **L** = L1 115VAC, **G** = Ground, **N** = L2 115VAC

The 230VAC is connected to the motor at all times. This voltage operates the internal electronics and drives the motor. In addition, the motor requires a low voltage to operate. The low voltage to the motor is delivered to taps 1-5 and the

(C) terminal from the control relay. The motor accepts a communication signal of 24VAC on these taps. Instead of energizing a motor speed (winding) on a PSC motor for each demand (heat cool, constant fan); the communication voltage directs the motor to operate at the torque value stored for each tap.

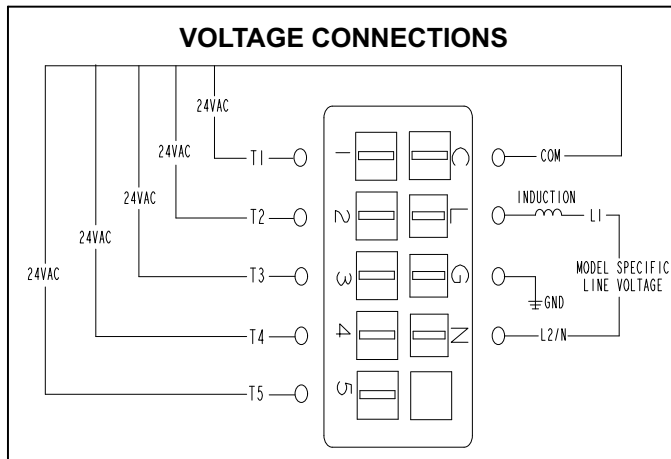

**FIGURE 15.**

During each demand, the fan motor will maintain the selected torque during changes in the systems external static pressure (ESP) (constant torque). If ESP increases the motor will use more power (current) to maintain torque. The motor has a programmed limit of operation to protect itself from damage, due to the energy it must use to maintain torque at high external static pressures. If the systems maximum total ESP is exceeded, torque will not be maintained, however the motor will deliver as much torque as possible, without causing damage to itself.

Constant torque allows the fan motor to maintain the torque (current) delivered to the motor when ESP is higher than recommended and/or changes during system operation. ESP (the resistance to the movement of air) is increased when duct work is undersized, poorly constructed and/or full or dirt or debris. ESP can increase during system operation when dirt builds up on the air distribution systems components, especially the filter, and when customers close or block grilles and registers. When torque is maintained, airflow does not decrease as fast as it would on a PSC motor system. This decreases the effect ESP has on loss of airflow, providing better system performance and efficiency within the limits of the motor design.

The fan motor has no programmable (On) delays but multiple (Off) delays (see table 4) are programmed into the motor. The off delay is programmed into the motor and can not be adjusted.

**Installation**

It is recommended that the electrical connections on the ECM be facing down or between the 4 and 8 O'clock position, and a drip loop formed out of the wiring harness leaving the motor. This is to prevent any moisture or water that may get into the motor area from running into the connectors where it could cause damage to the control.

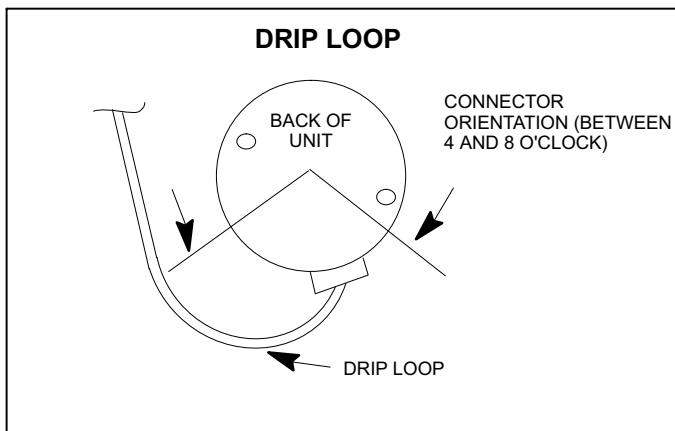

FIGURE 16

**⚠ DANGER**

Disconnect power from unit and wait at least five minutes to allow capacitors to discharge before attempting to service motor. Failure to wait may cause personal injury or death.

**INDOOR BLOWER MOTOR (B3) CONTROL TROUBLESHOOTING (REGAL-BELOIT)**

Before troubleshooting any HVAC system, it is a good practice to become familiar with the components and wiring diagram. On fan motor systems it is a good practice to check the tap selections and delay settings.

*If the motor is running* but the system is noisy, shutting down on its limits or safeties or the evaporator coil is freezing, there is a good chance the motor is good. The problem is most likely external to the motor.

- Check the tap selections using the HVAC OEM guide
- Check the air distribution system components for dirt load and closed dampers, registers and grilles.
- Measure the total external static pressure. Make repair(s) if above the recommended maximum level and confirm airflow at the new total ESP with the air flow tables (beginning on page 4). Aftermarket filter sizing is a common issue.

*If the motor is not running*, the following checks will diagnose whether it is operational. **Always disconnect the power to the HVAC system before disconnecting or reconnecting any connectors to these motors.** There are two inputs needed to operate this motor, a high voltage constant power source, and the low voltage communication that selects the torque value in each tap per demand.

**Checking 230VAC Voltage Input**

First check the high voltage to terminals (L) and (N). There should be 230VAC on these two terminals whenever there is power to the system, regardless of a demand call. Applying incorrect high voltage to the motor may cause the motor to not operate, or even damage the motor.

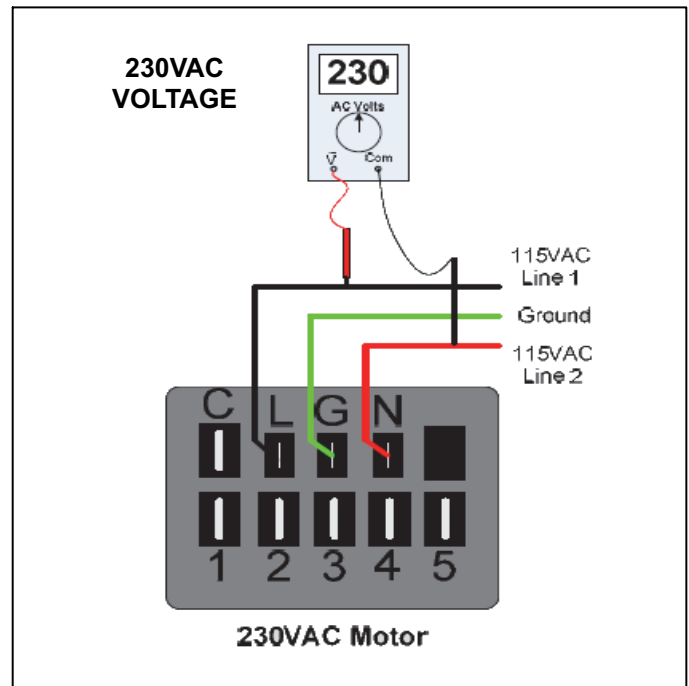

FIGURE 17

**Checking the Low-Voltage Communication Input**

If no low voltage communication (typically 24VAC) is measured at the motor on taps 1-5, check the HVAC system wiring, controls and demand call. Always check low voltage between terminals 1-5 and (C) at the motor, never ground. Once the problem is corrected, confirm that the low voltage communication is applied to a programmed tap. If proper low voltage communication is present at a programmed tap, with proper high voltage to the motor and it still does not operate, the motor is failed.

- 1- Initiate a demand from the thermostat and check the voltage between the common and the appropriate motor terminal 1- 5. Confirm the meter is set to the 24VAC.
- 2- If the low voltage communication is not present, check the demand from the thermostat. Also check the output terminal and wires from the K20 blower relay.
- 3- If the motor has proper high voltage as identified in the previous section, and proper low voltage to a programmed terminal, and motor is not operating, the motor has failed. Replace motor.

# VII-WIRING DIAGRAMS AND SEQUENCE OF OPERATIONS

## A- CBA27UHE Units 208/230V/460V SINGLE PHASE - SEQUENCE OF OPERATION

- 1- Line voltage is routed to transformer T1 and blower motor B3.
- 2- T1 supplies 24VAC to terminal strip TB1, which supplies 24VAC to the indoor thermostat and electric heat, if used.

### SINGLE-STAGE COOLING (Y1 to Y2 jumper in place)

- 6- When there is a call for cooling, Y2 of the thermostat energizes blower on cooling speed.

### TWO-STAGE THERMOSTAT

(remove jumper between Y1 and Y2)

### FIRST-STAGE COOLING

- 7- When there is a call for cooling, Y1 sends power through the room thermostat to G to energizes blower on first stage cooling speed.

### SECOND-STAGE COOLING

- 8- When there is a call for second stage cooling, Y2 of the thermostat energizes blower on cooling speed.

### HEATING

- 3- When there is a call for heat, W1 of the thermostat energizes the electric heat relay K32 (covered in the electric heat section).
- 4- Blower motor B3 is energized on heating speed after K20-1 closes.
- 5- Economizer (if used) is energized.

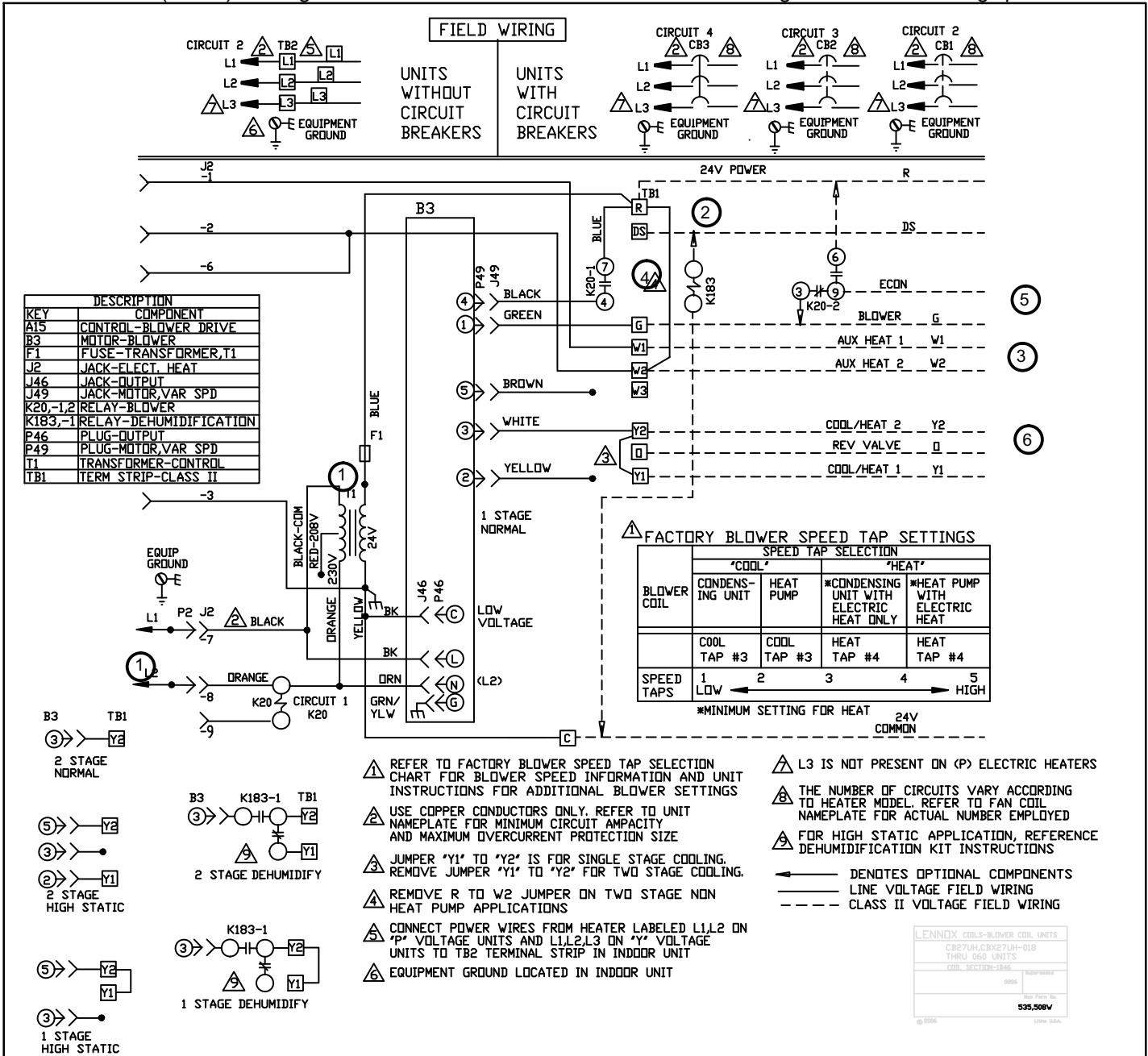

208/230V - Single Phase

### FIELD WIRING FOR UNITS WITHOUT CIRCUIT BREAKERS

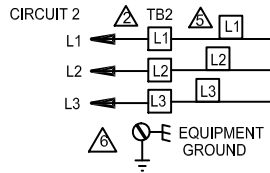

- ⚠ CONNECT POWER WIRES FROM HEATER LABELED L1, L2, L3 ON G VOLTAGE UNITS TO TB2 TERMINAL STRIP IN INDOOR UNIT
- ⚠ EQUIPMENT GROUND LOCATED IN INDOOR UNIT

### FIELD WIRING FOR UNITS WITH CIRCUIT BREAKERS

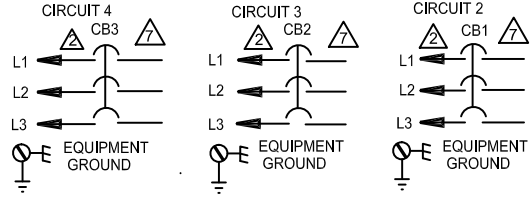

- ⚠ THE NUMBER OF CIRCUITS VARY ACCORDING TO HEATER MODEL. REFER TO FAN COIL NAMEPLATE FOR ACTUAL NUMBER EMPLOYED

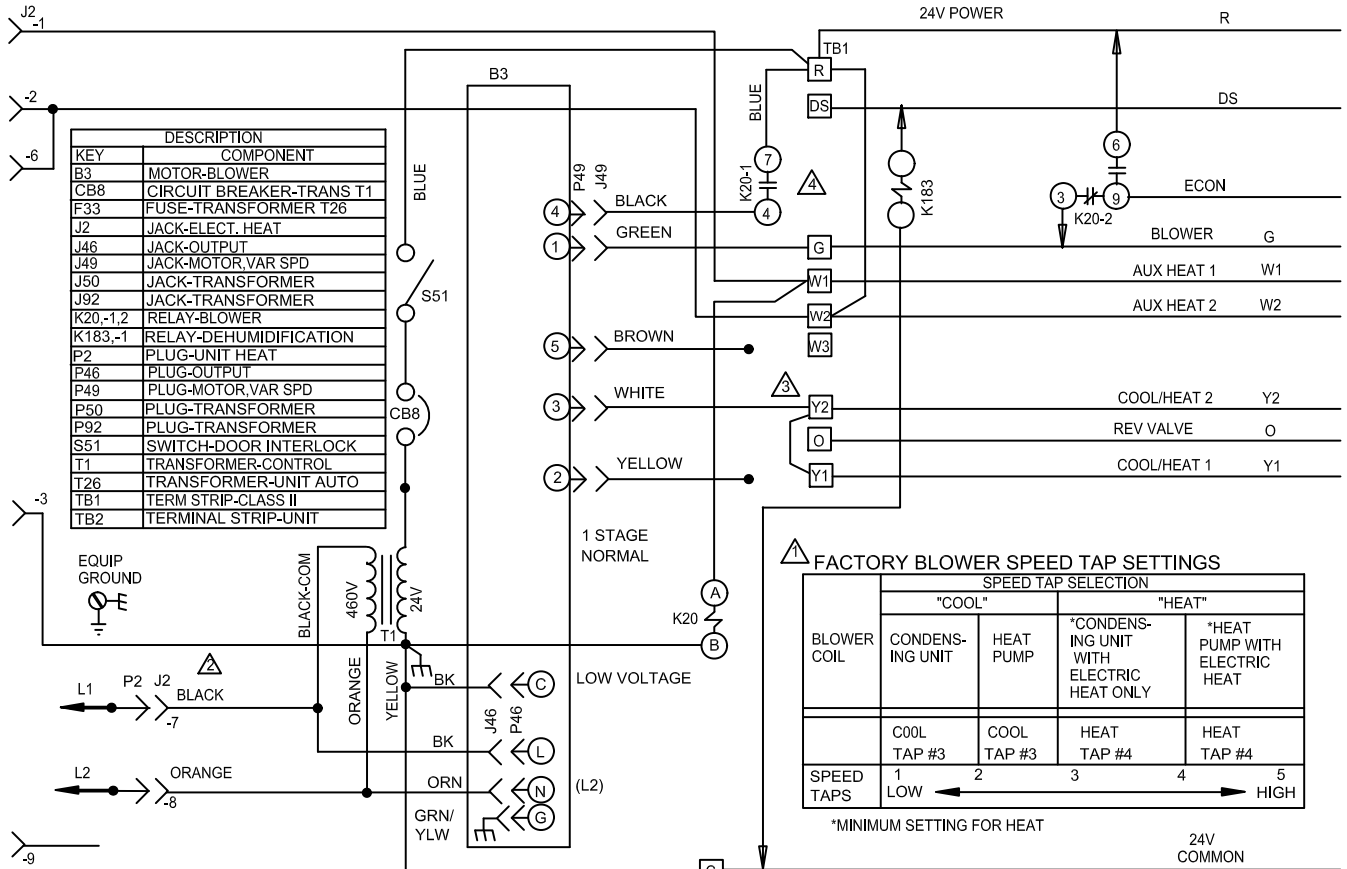

#### FACTORY BLOWER SPEED TAP SETTINGS

BLOWER COIL	SPEED TAP SELECTION			
	"COOL"		"HEAT"	
	CONDENS- ING UNIT	HEAT PUMP	*CONDENS- ING UNIT WITH ELECTRIC HEAT ONLY	*HEAT PUMP WITH ELECTRIC HEAT
	COOL TAP #3	COOL TAP #3	HEAT TAP #4	HEAT TAP #4
SPEED TAPS	1	2	3	4
	LOW			HIGH

\*MINIMUM SETTING FOR HEAT

24V  
COMMON

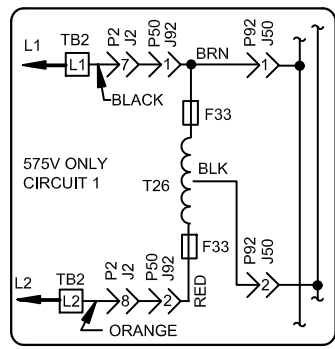
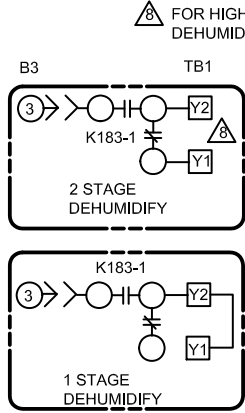
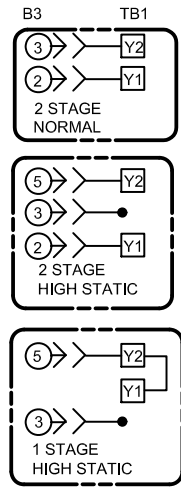

— DENOTES OPTIONAL COMPONENTS  
 — LINE VOLTAGE FIELD WIRING  
 — CLASS II VOLTAGE FIELD WIRING

- ⚠ REFER TO FACTORY BLOWER SPEED TAP SELECTION CHART FOR BLOWER SPEED INFORMATION AND UNIT INSTRUCTIONS FOR ADDITIONAL BLOWER SETTINGS
- ⚠ USE COPPER CONDUCTORS ONLY. REFER TO UNIT NAMEPLATE FOR MINIMUM CIRCUIT AMPACITY AND MAXIMUM OVERCURRENT PROTECTION SIZE
- ⚠ JUMPER "Y1" TO "Y2" IS FOR SINGLE STAGE COOLING. REMOVE JUMPER "Y1" TO "Y2" FOR TWO STAGE COOLING.
- ⚠ REMOVE R TO W2 JUMPER ON TWO STAGE NON HEAT PUMP APPLICATIONS

## 460V - Single Phase

# B-ECB29-2.5, -4, -5, -6, 4CB, 5CB, 6CB - 208/230V SINGLE PHASE - SEQUENCE OF OPERATION

- 1- When there is a call for heat, W1 of the thermostat energizes the electric heat relay K35 with 24VAC.
- 2- When K35-1 closes, the blower is energized on heating speed.
- 3- Assuming the N.C. primary (S15) and secondary (S20) limit switches are closed, electric heat element HE1 is energized.

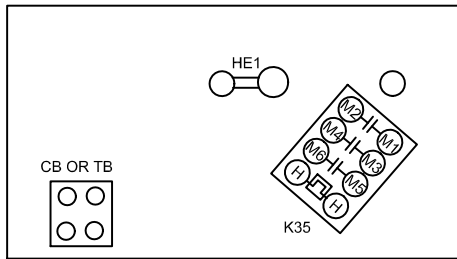

KEY	DESCRIPTION	COMPONENT
CB1	CIRCUIT BREAKER-ELECT HEAT	
HE1	ELEMENT-ELECTRIC HEAT 1	
K32,-1,2	RELAY-ELECTRIC HEAT	
P2	PLUG-ELECTRIC HEAT	
S15	SWITCH-LIMIT, PRIMARY, ELECT HEAT	
S20	SWITCH-LIMIT, SECONDARY, ELECT HEAT	
TB2	TERMINAL STRIP-UNIT	

- NOTE: USE COPPER CONDUCTORS ONLY
- ⚠ REFER TO UNIT NAMEPLATE FOR MINIMUM CIRCUIT AMPACITY AND MAXIMUM OVERCURRENT PROTECTION SIZE.
  - ⚠ CONNECT POWER WIRES FROM UNIT LABELED L1 AND L2 TO TB2 TERMINAL STRIP ON HEATER PLATE
  - ⚠ EQUIPMENT GROUND IS LOCATED IN INDOOR UNIT

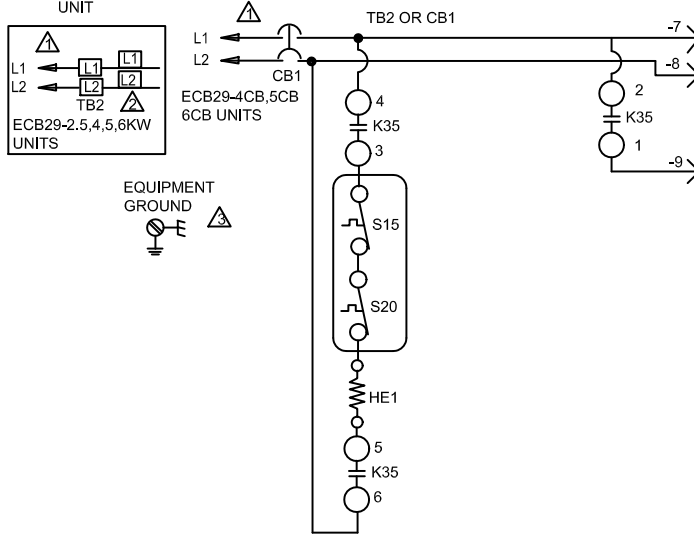

— LINE VOLTAGE FIELD INSTALLED

HEATING-ELECTRIC	
ECB29-2.5, 4, 5, 6, 4CB, 5CB, 6CB-6P	
Supersedes	
0714	Form No. <b>537764-01</b>

© 2011

Litho U.S.A.

# C-ECB29-8, 8CB 208/230V SINGLE PHASE - SEQUENCE OF OPERATION

- 1- When there is a call for heat, W1 of the thermostat energizes the electric heat relays K32 and K33 with 24VAC.
- 2- When K32-1 closes, the blower is energized on heating speed.
- 3- When K32-2 and K32-3 close, assuming N.C. primary (S15) and the secondary (S20) limit switches are closed, electric heat element HE1 is energized.
- 4- When K33-1 and K33-2 close, assuming N.C. primary (S10) and the secondary (S20) limit switches are closed, electric heat element HE2 is energized.

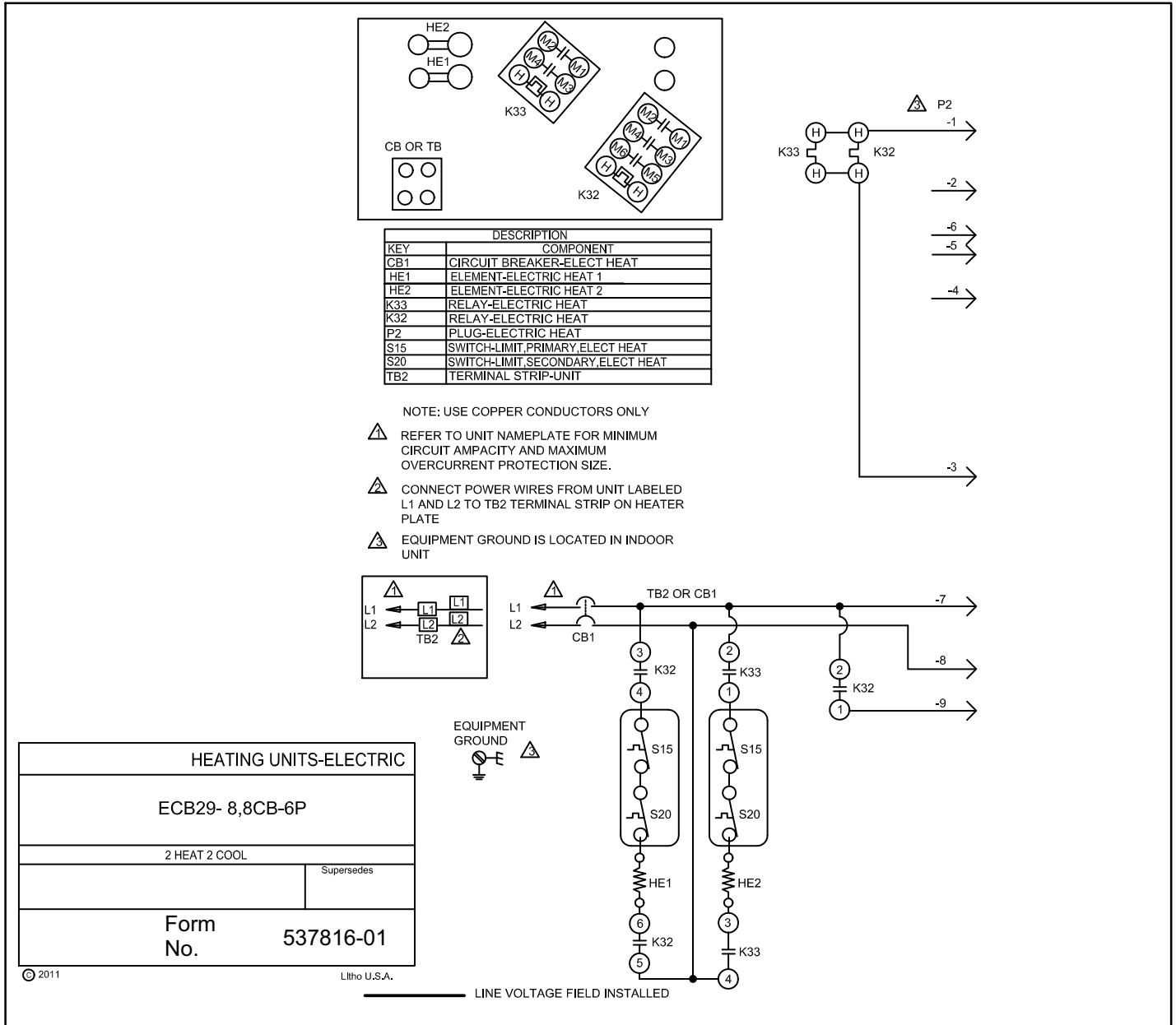

# D-ECB29-9CB, 10, 10CB - 208/230V SINGLE PHASE - SEQUENCE OF OPERATION

## FIRST STAGE HEAT

- 1- When there is a call for heat, W1 of the thermostat energizes the electric heat relays K32 and K33 with 24VAC.
- 2- When K32-1 closes, the blower is energized on heating speed.
- 3- K32-2 and K32-3 close and assuming the N.C. primary (S15) and secondary (S20) limit switches are closed, electric heat element HE1 is energized.

## SECOND STAGE HEAT

(remove jumper between W2 and R)

- 4- When K33-1 closes, the unit is ready for a second stage heat demand. W2 of the thermostat sends a second stage heat demand, energizing the electric heat relay K34 with 24VAC.
- 5- When K34-1 and K34-2 close, assuming the N.C. primary (S15) and secondary (S20) limit switches are closed, electric heat element HE2 is energized.

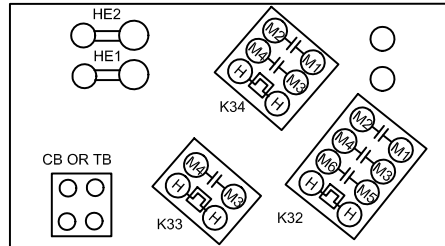

KEY	DESCRIPTION
CB1	CIRCUIT BREAKER-ELECT HEAT
HE1	ELEMENT-ELECTRIC HEAT 1
HE2	ELEMENT-ELECTRIC HEAT 2
K32	RELAY-ELECTRIC HEAT
K33	RELAY-ELECTRIC HEAT
K34	RELAY-ELECTRIC HEAT
P2	PLUG-ELECTRIC HEAT
S15	SWITCH-LIMIT, PRIMARY, ELECT HEAT
S20	SWITCH-LIMIT, SECONDARY, ELECT HEAT
TB2	TERMINAL STRIP-UNIT

- NOTE: USE COPPER CONDUCTORS ONLY
- ⚠ REFER TO UNIT NAMEPLATE FOR MINIMUM CIRCUIT AMPACITY AND MAXIMUM OVERCURRENT PROTECTION SIZE.
  - ⚠ CONNECT POWER WIRES FROM UNIT LABELED L1 AND L2 TO TB2 TERMINAL STRIP ON HEATER PLATE
  - ⚠ EQUIPMENT GROUND IS LOCATED IN INDOOR UNIT

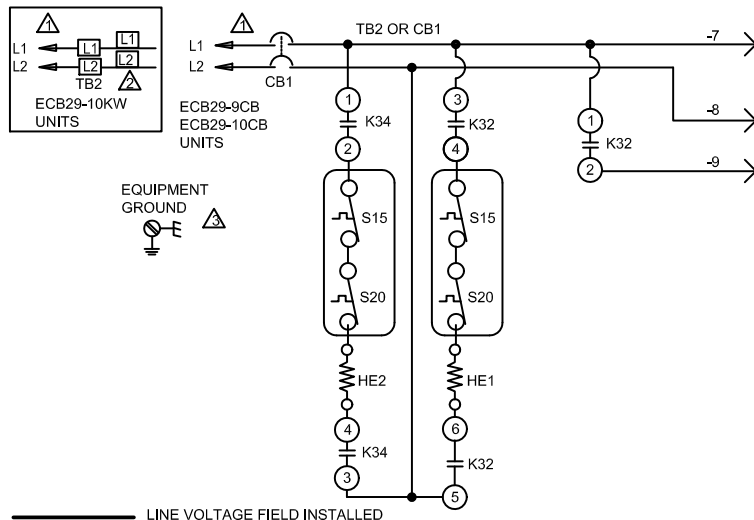
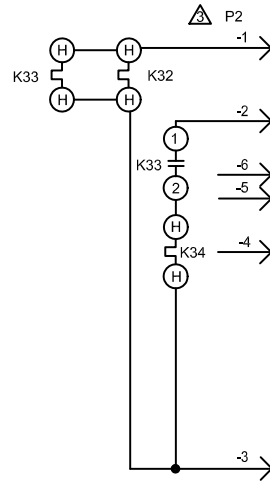

HEATING UNITS-ELECTRIC	
ECB29-9CB, 10, 10CB-7P	
2 HEAT 2 COOL	
Supersedes	
0615	Form No. 537770-02

# E-ECB29-12.5CB, -15CB - 208/230V SINGLE PHASE - SEQUENCE OF OPERATION

## FIRST STAGE HEAT

- 1- When there is a call for heat, W1 of the thermostat energizes electric heat relays K32 and K33 with 24VAC.
- 2- When K32-1 closes, the blower is energized on heating speed.
- 3- When K32-2 and K32-3 close, assuming the N.C. primary (S15) and secondary (S20) limit switches are closed, electric heat element HE1 is energized.

## SECOND STAGE HEAT

(remove jumper between W2 and R)

- 4- When K33-1 closes, the unit is ready for a second stage heat demand. When K33-2 and K33-3 close, assuming the N.C. primary (S15) and secondary (S20) limit switches are closed, electric heat element HE2 is energized.
- 5- W2 of the thermostat sends a second stage heat demand, energizing electric heat relay K34 with 24VAC.
- 6- When K34-1 and K34-2 close, assuming the N.C. primary (S15) and secondary (S20) limit switches are closed, heating element HE3 is energized.

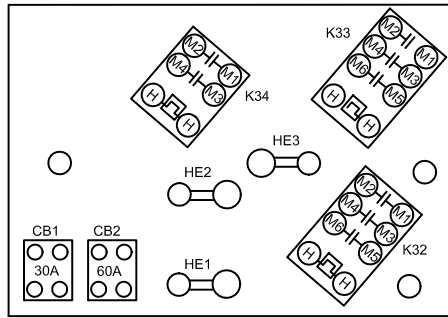

DESCRIPTION	
KEY	COMPONENT
CB1	CIRCUIT BREAKER-ELECT HEAT
CB2	CIRCUIT BREAKER-ELECT HEAT
HE1	ELEMENT-ELECTRIC HEAT 1
HE2	ELEMENT-ELECTRIC HEAT 2
HE3	ELEMENT-ELECTRIC HEAT 3
K32	RELAY-ELECTRIC HEAT
K33	RELAY-ELECTRIC HEAT
K34	RELAY-ELECTRIC HEAT
P2	PLUG-ELECTRIC HEAT
S15	SWITCH-LIMIT, PRIMARY, ELECT HEAT
S20	SWITCH-LIMIT, SECONDARY, ELECT HEAT

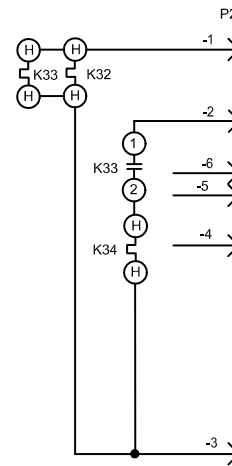

⚠ REFER TO UNIT NAMEPLATE FOR MINIMUM CIRCUIT AMPACITY AND MAXIMUM OVERCURRENT PROTECTION SIZE.  
 — LINE VOLTAGE FIELD INSTALLED  
 ← DENOTES OPTIONAL COMPONENTS

NOTE: USE COPPER CONDUCTORS ONLY

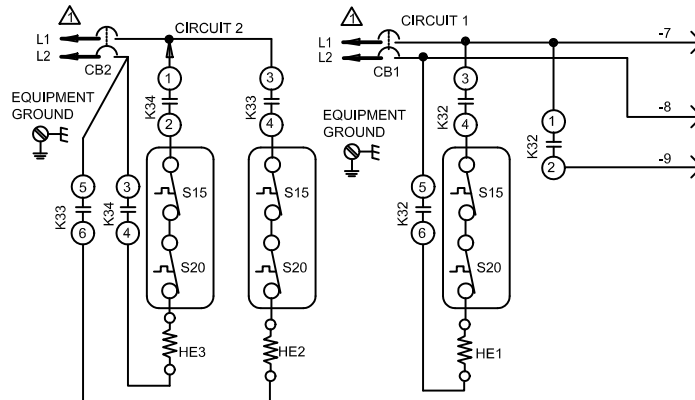

HEATING UNITS-ELECTRIC	
ECB29-12.5CB-7P ECB29-15CB-7P	
2 HEAT 2 COOL	
Supersedes	
Form No.	537787-02

© 2011

Litho U.S.A.

# F-ECB29-20CB - 208/230V SINGLE PHASE - SEQUENCE OF OPERATION

## FIRST STAGE HEAT

- 1- When there is a call for heat, W1 of the thermostat energizes the electric heat relays.
- 2- When K32-1 closes, the blower is energized on heating speed.
- 3- When K32-2 and K32-3 close, assuming the N.C. primary (S15) and secondary (S20) limit switches are closed, electric heat element HE1 is energized.
- 4- When K33-2 and K32-3 close, assuming the N.C. primary (S15) and secondary (S20) limit switches are closed, electric heat element HE2 is energized.

## SECOND STAGE HEAT

(remove jumper between W2 and R)

- 5- W2 of the thermostat sends a second stage heat demand, energizing the electric heat relays K34 and K35 with 24VAC. When K34-2 and K34-3 close, assuming the N.C. primary (S15) and secondary (S20) limit switches are closed, heating element HE3 is energized. When K35-2 and K35-3 close, assuming the N.C. primary (S15) and secondary (S20) limit switches are closed, electric heat element HE4 is energized.

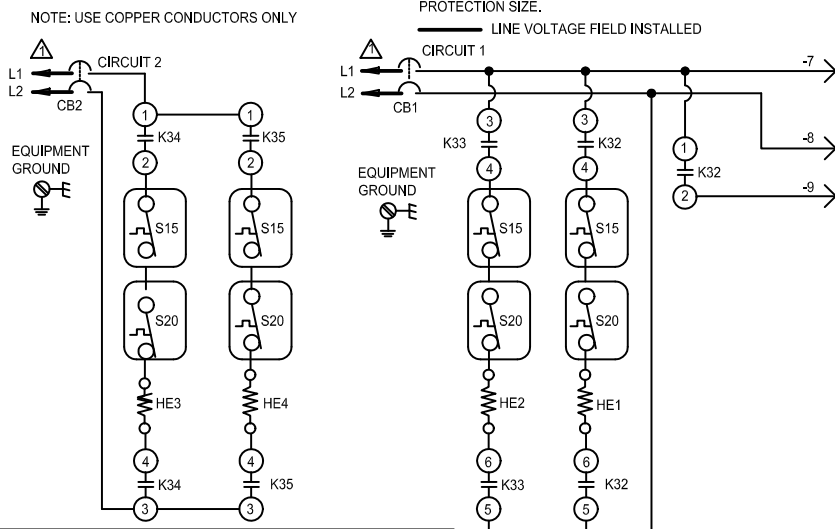
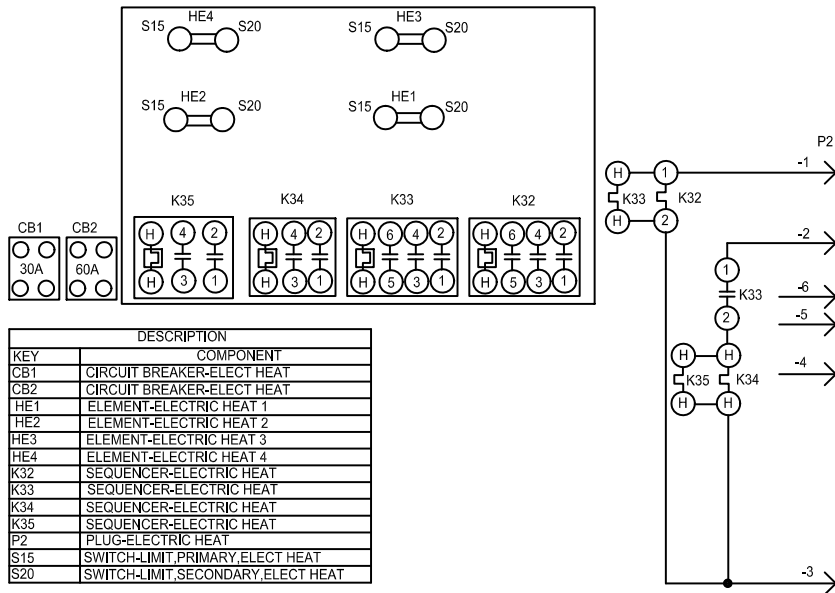

HEATING UNITS-ELECTRIC	
ECB29-20CB-9P	
2 HEAT 2 COOL	
	Supersedes
Form No.	537760-02

# G-ECB29-25CB - 208/230V SINGLE PHASE - SEQUENCE OF OPERATION

## FIRST STAGE HEAT

- 1- When there is a call for heat, W1 of the thermostat energizes the electric heat relays K32 and K34 with 24VAC.
- 2- When K32-1 closes, the blower is energized on heating speed.
- 3- When K32-2 and K32-3 close, assuming the N.C. primary (S15) and secondary (S20) limit switches are closed, electric heat element HE1 is energized.
- 4- When K34-2 and K34-3 close, assuming the N.C. primary (S15) and secondary (S20) limit switches are closed, electric heat element HE2 is energized.

## SECOND STAGE HEAT

*(remove jumper between W2 and R)*

- 5- When K34-1 closes, the unit is ready for a second stage heat demand. W2 of the thermostat sends a second stage heat demand, energizing the electric heat relays K33 and K117 with 24VAC.

- 6- When K33-2, K33-3, K117-1 and K117-2 close, assuming primary (S15) and secondary (S20) limit switches are closed, electric heat elements HE3 and HE6 are energized.

## THIRD STAGE HEAT

*(remove jumper between W3 and R, if using third stage)*

- 7- When K33-1 closes, the unit is ready for a third stage heat demand. W3, if available, of the thermostat sends a third stage heat demand, energizing the electric heat relays K35 and K116 with 24VAC.
- 8- When K35-1, K35-2, K116-1 and K116-2 close, assuming the N.C. primary (S15) and secondary (S20) limit switches are closed, electric heat elements HE4 and HE5 are energized.

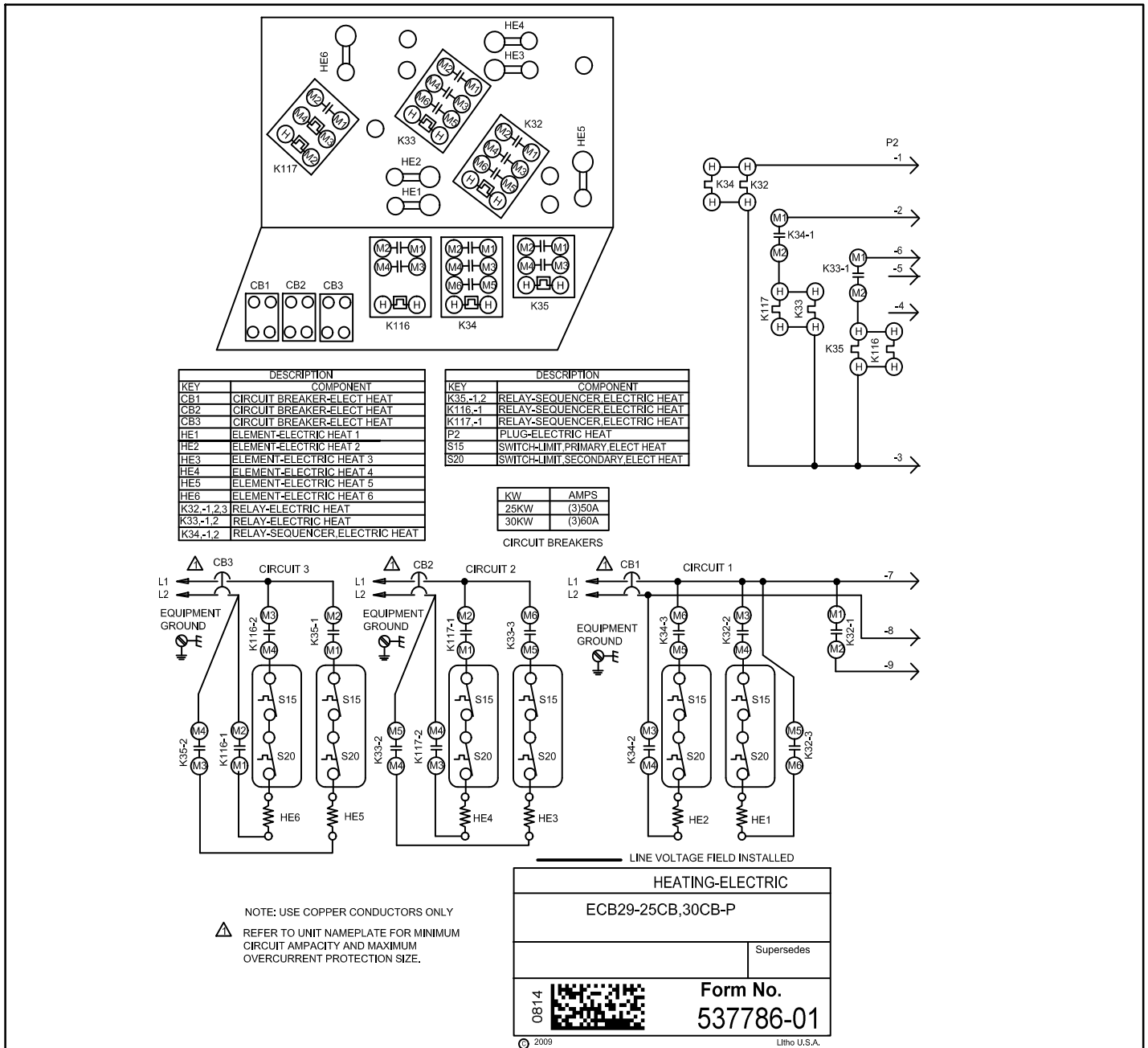

# H-ECB29 -8, -10 - 208/230V THREE PHASE - SEQUENCE OF OPERATION

- 1- When there is a call for heat, W1 of the thermostat energizes the electric heat contactor K1.
- 2- When K1 contacts M1 and M2 close, the blower is energized on heating speed.
- 3- When K1 contactor closes, assuming the N.C. primary (S15) and secondary (S20) limit switches are closed, electric heat elements HE1, HE2, and HE3 are energized.

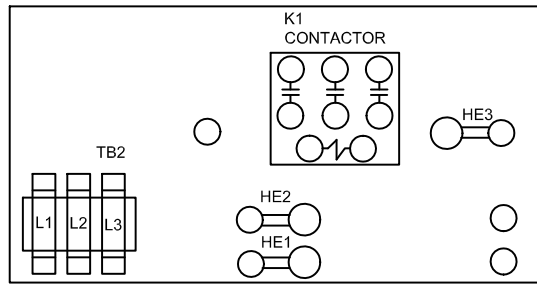

DESCRIPTION	
KEY	COMPONENT
CB1	CIRCUIT BREAKER-ELECT HEAT
HE1	ELEMENT-ELECTRIC HEAT 1
HE2	ELEMENT-ELECTRIC HEAT 2
HE3	ELEMENT-ELECTRIC HEAT 3
K1	CONTACTOR
P2	PLUG-ELECTRIC HEAT
S15	SWITCH-LIMIT, PRIMARY, ELECT HEAT
S20	SWITCH-LIMIT, SECONDARY, ELECT HEAT
TB2	TERMINAL STRIP-ELECTRIC HEAT

NOTE: USE COPPER CONDUCTORS ONLY

- ⚠ CONNECT POWER WIRES FROM HEATER, LABELED L1, L2, AND L3 TO TB2 TERMINAL STRIP INSIDE INDOOR UNIT
- ⚠ REFER TO UNIT NAMEPLATE FOR MINIMUM CIRCUIT AMPACITY AND MAXIMUM OVERCURRENT PROTECTION SIZE.
- ⚠ EQUIPMENT GROUND IS LOCATED IN INDOOR UNIT

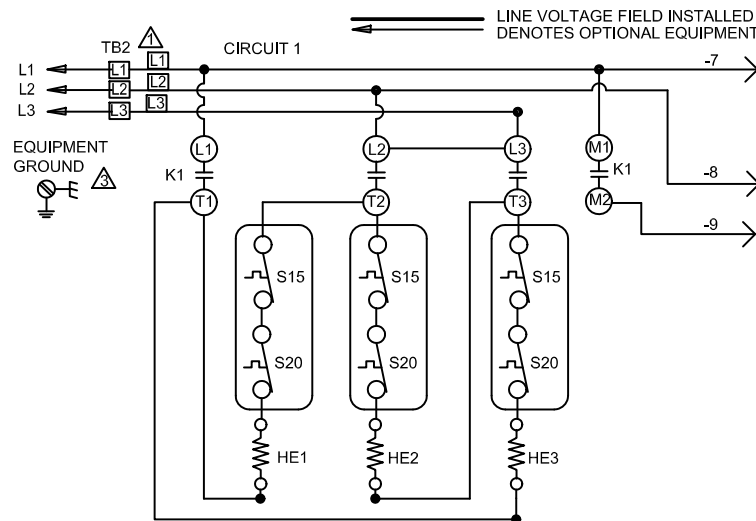
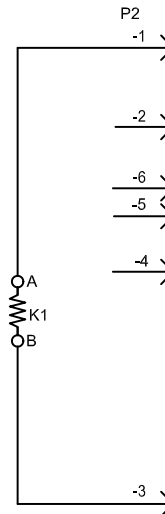

HEATING-ELECTRIC	
ECB29-8,10-4-Y	
Supersedes	
0714	Form No. <b>537772-01</b>

© 2009

Litho U.S.A.

# I-ECB29 -15CB - 208/230V THREE PHASE - SEQUENCE OF OPERATION

- 1- When there is a call for heat, W1 of the thermostat energizes the electric heat contactor K1.
- 2- When K1 contacts M1 and M2 close, the blower is energized on heating speed.
- 3- When K1 contactor closes, assuming the N.C. primary (S15) and secondary (S20) limit switches are closed, electric heat elements HE1, HE2, and HE3 are energized.

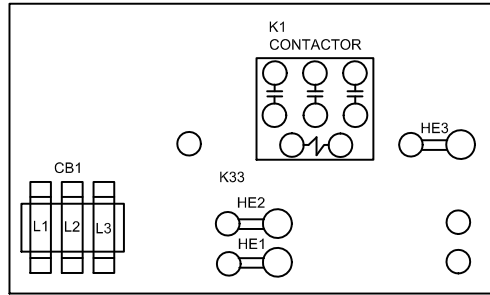

KEY	DESCRIPTION	COMPONENT
CB1	CIRCUIT BREAKER-ELECT HEAT	
HE1	ELEMENT-ELECTRIC HEAT 1	
HE2	ELEMENT-ELECTRIC HEAT 2	
HE3	ELEMENT-ELECTRIC HEAT 3	
K1	CONTACTOR	
P2	PLUG-ELECTRIC HEAT	
S15	SWITCH-LIMIT, PRIMARY, ELECT HEAT	
S20	SWITCH-LIMIT, SECONDARY, ELECT HEAT	

- NOTE: USE COPPER CONDUCTORS ONLY
- ⚠ REFER TO UNIT NAMEPLATE FOR MINIMUM CIRCUIT AMPACITY AND MAXIMUM OVERCURRENT PROTECTION SIZE.
  - ⚠ EQUIPMENT GROUND IS LOCATED IN INDOOR UNIT

NOTE-USE 50 AMP CIRCUIT BREAKER

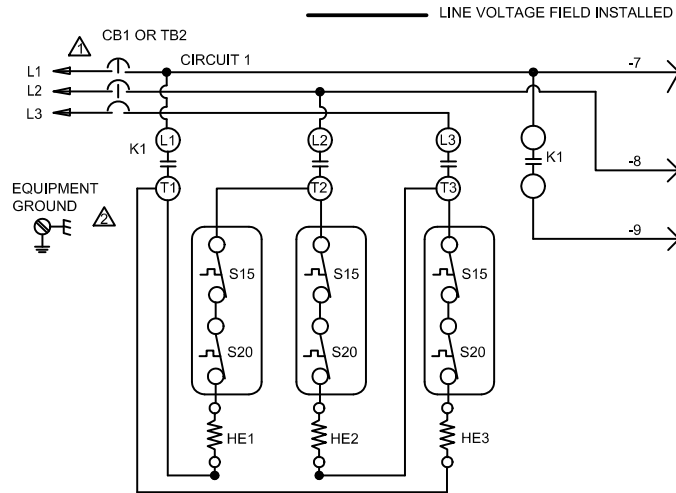
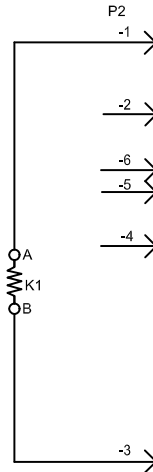

HEATING-ELECTRIC	
ECB29-15CB-4-Y	
Supersedes	
Form No.	<b>537771-01</b>

© 2011

Litro U.S.A.

# J-ECB29-20CB, -25CB - 208/230V THREE PHASE - SEQUENCE OF OPERATION

## FIRST STAGE HEAT

- 1- When there is a call for heat, W1 of the thermostat energizes the electric heat contactor K1 with 24VAC.
- 2- When K1-1 closes, the blower is energized on heating speed.
- 3- When K1 contactor closes, assuming the N.C. primary (S15) and secondary (S20) limit switches are closed, electric heat elements HE1, HE2 and HE3 are energized.

## SECOND STAGE HEAT

(remove jumper between W2 and R)

- 4- W2 of the thermostat sends a second stage heat demand, energizing the electric heat contactor K2 with 24VAC.
- 5- When K2-1 closes, the blower (if not energized) is energized on heating speed.
- 6- When K2 contactor contacts close, assuming the N.C. primary (S15) and secondary (S20) limit switches are closed, electric heat elements HE4, HE5, and HE6 are energized.

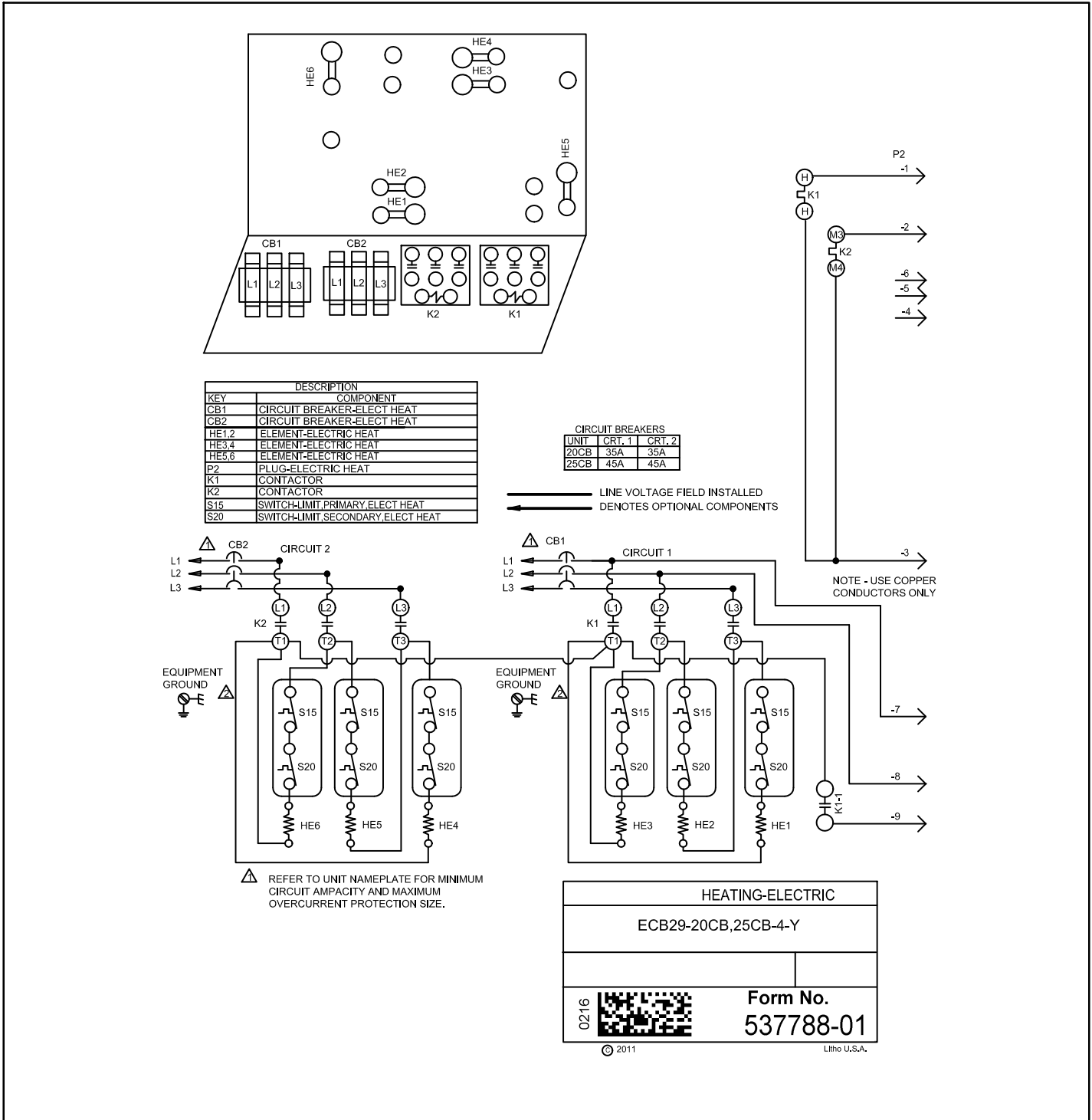

# K-ECB29-10, -15, -20 and -25CB - 460V THREE PHASE - SEQUENCE OF OPERATION

## FIRST STAGE HEAT

- 1- When there is a call for heat, W1 of the thermostat energizes the electric heat relays K32 and K34 with 24VAC.
- 2- When K32-1 closes, the blower is energized on heating speed.
- 3- When K32-1 and K32-2 closes, assuming the N.C. primary (S15) and secondary (S20) limit switches are closed, electric heat elements HE 1 and HE2 are energized.
- 4- When K34-1 closes, assuming the N.C. primary (S15) and secondary (S20) limit switches are closed, electric heat element HE3 is energized.

## SECOND STAGE HEAT

(remove jumper between W2 and R)

- 5- When K34-2 closes, the unit is ready for a second stage heat demand. W2 of the thermostat sends a second stage heat demand, energizing the electric heat relays K33 and K35 with 24VAC.
- 6- When K33-1 closes, the blower (if not energized) is energized on heating speed and economizer heat relay K43 is energized (see 208/230VAC CB schematic).
- 7- When K33-1, K35-1, and K35-2 contacts close, assuming the N.C. primary (S15) and secondary (S20) limit switches are closed, electric heat elements HE4, HE5, and HE6 are energized.

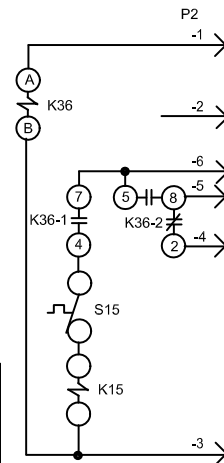
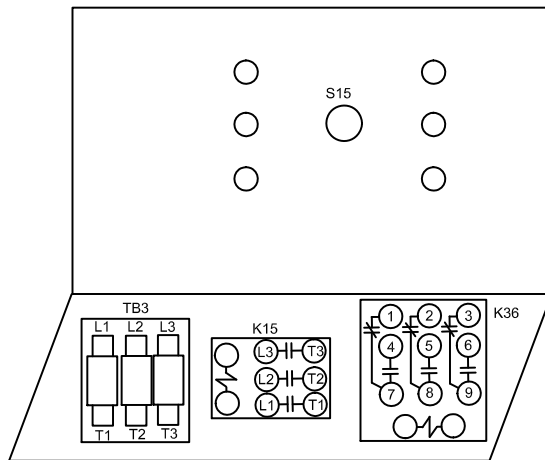

△ FUSE SIZE CHART

UNIT	VOLTAGE	FUSE SIZE
ECB29-10	G	20A
	J	—
ECB29-15	G	25A
	J	—
ECB29-20	G	35A
	J	25A
ECB29-25	G	40A
	J	35A

KEY	DESCRIPTION
	COMPONENT
F3	FUSE-ELECTRIC HEAT
HE1	ELEMENT-ELECTRIC HEAT 1
K15,-1	CONTACTOR-ELECTRIC HEAT
K36,-1,2,3	RELAY-HEAT BLOWER
P2	PLUG-ELECTRIC HEAT
S15	SWITCH-LIMIT, PRIMARY ELECT HEAT
S20	SWITCH-LIMIT, SECONDARY ELECT HEAT
TB3	TERMINAL STRIP-ELECTRIC HEAT

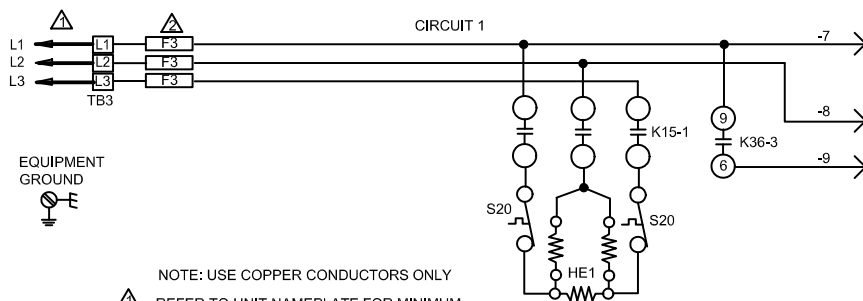

NOTE: USE COPPER CONDUCTORS ONLY  
 △ REFER TO UNIT NAMEPLATE FOR MINIMUM CIRCUIT AMPACITY AND MAXIMUM OVERCURRENT PROTECTION SIZE.

LINE VOLTAGE FIELD INSTALLED	
HEATING-ELECTRIC	
ECB29-10,15,20,25-G	
ECB29-20,25-J	
AECB29-10,15,20-G	
1009	Supersedes
New Form No.	
531,708W	



## L-CBA27UHE with DEHUMIDIFICATION RELAY K183

### Operation Sequence

- 1-. If there is no dehumidification demand when 24 volts is applied to the system, the thermostat will send 24 volts to the K183 dehumidification relay coil. The normally-open relay contacts 5 and 9 will close and contacts 1 and 9 will open.
- 2-. If the total system static is higher than 0.49 in. w.g., a higher indoor blower speed may be needed to satisfy supply air requirements.
- 3-. The lower the indoor blower speed during dehumidification demands, without freezing the indoor coil, the better moisture removal will be. In Humiditrol® applications, this lower speed will increase the temperature rise on the Humiditrol® coil.
- 4-. When more than one motor tap is energized, built in logic gives the highest speed tap precedence.
- 5-. On a dehumidification call, the thermostat will remove 24 volt output from the "D" terminal; the "Y2" terminal (if available) becomes activated with 24 volts. This will de-energize K183 dehumidification relay and output 24 volts from Y2.

**NOTE - For any of the following configurations, refer to figure wiring diagram for proper system indoor blower fan speed tap selection.**

### Single Stage Systems

**Y1 cooling demand from the room thermostat with no dehumidification demand**—24 volts passes to the Y1 terminal on the coil blower. The factory jumper from Y1 and Y2 will direct the 24 volt signal through the closed set of contacts to the selected indoor blower cooling speed (factory set on Tap # 3 - white wire). Systems with total system statics between 0.50 and 0.80 in. w.g. may require a motor speed change.

**Y1 cooling demand with dehumidification demand**—K183 relay de-energizes. Contacts 5 and 9 open and isolate the cooling tap speed on the motor from the system. The room thermostat will still be calling for a Y1 demand, so 24 volts will still output from the Y1 and G terminals. The Y1 signal (factory jumpered to Y2 on the indoor unit's 24 volt terminal strip) will be isolated from the indoor blower motor by the opening of contacts 5 to 9 but the G signal will still be able to provide 24 volt power to the continuous indoor blower speed (factory set on Tap # 1 - green wire). Systems with total system statics between 0.50 and 0.80 in. w.g. may require a motor speed change.

### Two Stage Systems

**NOTE - Factory jumper wire between Y1 and Y2 on the indoor unit 24 volt terminal strip must be removed for two-stage systems.**

**Y1 cooling demand from the room thermostat with no dehumidification demand**—24 volts passes to the Y1 terminal on the coil blower. The Y1 demand will be isolated from the cooling tap speed on the indoor blower motor by removal of the jumper between Y1 and Y2 on the indoor unit's terminal strip on systems where the total system static is less than 0.50 in. w.g. The room thermostat outputs Y1 and G on a Y1 demand. The G signal from the room thermostat will still provide 24 volt power to the continuous indoor blower speed (factory set on Tap # 1 - green wire).

Systems with total system statics between 0.50 and 0.80 in. w.g. will require the yellow wires from the K183 relay terminal 1 to be connected to Y1 on the unit's indoor terminal strip and Tap # 2 (yellow from the indoor blower motor). The Y1 input from the indoor unit will allow the indoor blower motor to run on Tap # 2 - yellow wire.

The G signal from the room thermostat will still provide 24 volt power to the continuous indoor blower speed (factory set on Tap # 1 - green wire).

**Y2 cooling demand from the room thermostat with no dehumidification demand**—24 volts passes to the Y2 terminal on the coil blower. The Y2 demand will pass through closed relay contacts 5 and 9 to the selected indoor blower cooling speed (factory set on Tap # 3 - white wire). Systems with total system statics between 0.50 and 0.80 in. w.g. may require a motor speed change.

**Y1 or Y1/Y2 cooling demand with dehumidification demand**—K183 relay de-energizes and the room thermostat Y2 energizes. K183 relay contacts 5 and 9 will open and isolate the cooling blower speed on the motor from the system. The room thermostat will still be calling for a Y1, Y2, and G demand, so 24 volts will still be output to the terminal strip in the indoor coil blower. Y1 is not wired to the K183 relay, Y2 will send 24 volts through the K183 relay 9 to 1 closed contacts to the yellow wire that is not connected to the motor in systems where the total system static is less than 0.50 in. w.g. The G signal will still provide 24 volt power to motor Tap # 1 - Green wire. Indoor blower motor will run on Tap # 1 - Green wire. Systems with total system statics between 0.50 and 0.80 in. w.g. may require a motor speed change.

Systems with total system statics between 0.50 and 0.80 in. w.g. will require the yellow wires from the K183 relay terminal 1 to be connected to Y1 on the unit's indoor terminal strip and Tap # 2 - yellow from the indoor blower motor. The Y1 input from the indoor unit will allow the indoor blower motor to run on Tap # 2 - Yellow wire. The Y2 demand will go through K183 relay contacts 9 to 1 to indoor blower motor speed Tap # 2 - Yellow wire. The G signal will still provide 24 volt power to motor Tap # 1 - Green wire. The indoor blower motor will run on Tap # 2 - Yellow wire.

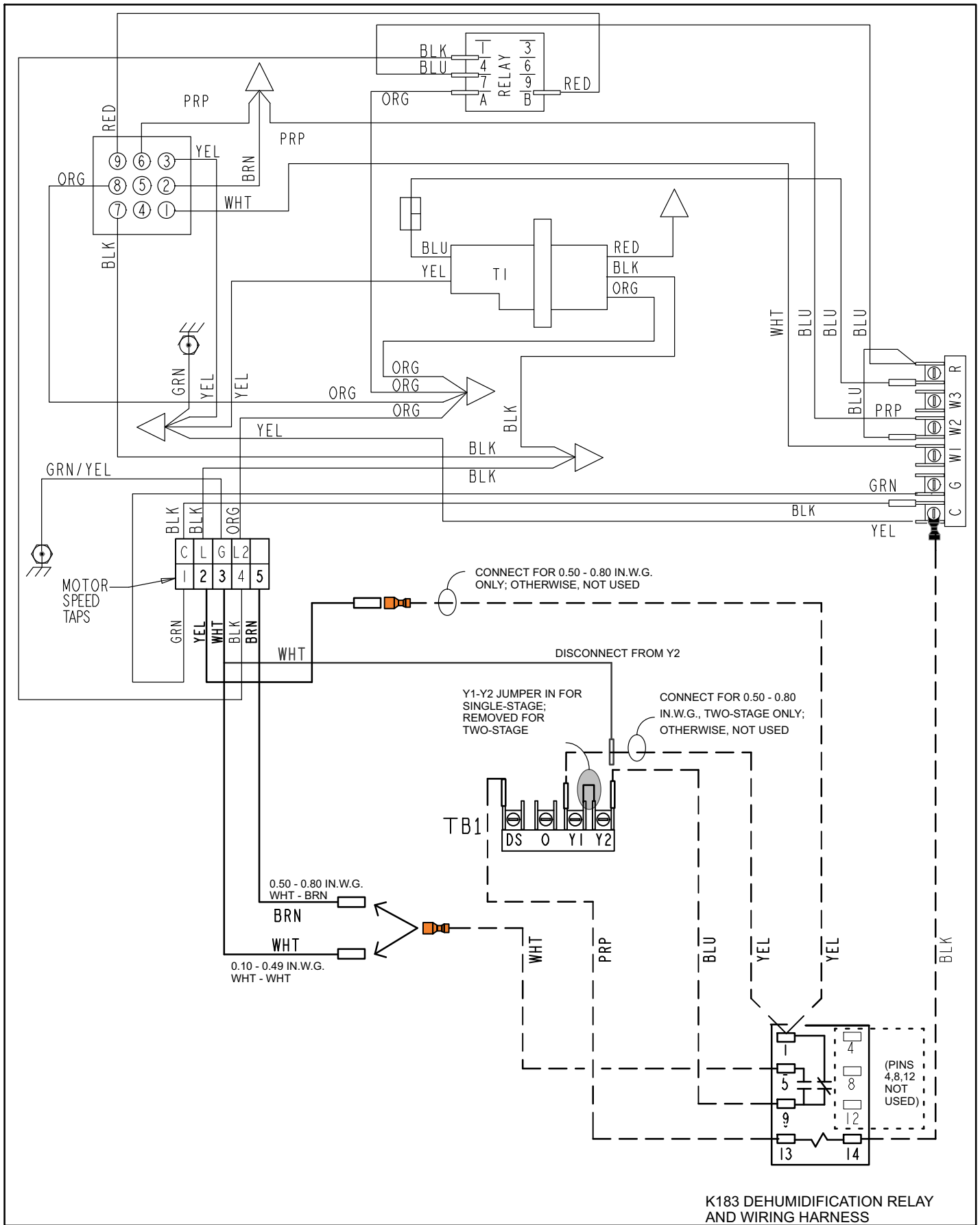

K183 DEHUMIDIFICATION RELAY AND WIRING HARNESS

See unit nameplate for manufacturer and address.

©2024

508460-01

4/2024

## R-454B

# USER'S INFORMATION MANUAL

**LG/LD 024, 036, 048, 060, 072, 074**

(2, 3, 4, 5, and 6 Tons)

**LG/LD 078, 092, 102, 120, 152**

(6-1/2, 7-1/2, 8-1/2, 10 and 12-1/2 Tons)

**LG/LD 156, 180, 210, 240, 300, 302, 360**

(13, 15, 17-1/2, 20 and 30 Tons)

## ROOFTOP UNITS

### Safety

- 1 - Keep unit area clear and free of combustible materials, gasoline and other flammable vapors and liquids.
- 2 - Do not obstruct air flow to unit. Unit must receive an unobstructed flow of combustion and ventilating air.

### WARNING



Danger of explosion and fire. Failure to follow safety warnings exactly could result in dangerous operation, serious injury, death or property damage.

### CAUTION

As with any mechanical equipment, contact with sharp sheet metal edges can result in personal injury. Take care while handling this equipment and wear gloves and protective clothing.

### WARNING

Improper installation, adjustment, alteration, service or maintenance can cause property damage, personal injury or loss of life. Installation and service must be performed by a licensed professional HVAC installer or equivalent, service agency, or the gas supplier.

### WARNING

To prevent serious injury or death:

- 1-Lock-out / tag-out before performing maintenance.
- 2-If system power is required (e.g., smoke detector maintenance), disable power to blower, remove fan belt where applicable, and ensure all controllers and thermostats are set to the "OFF" position before performing maintenance.
- 3-Always keep hands, hair, clothing, jewelry, tools, etc., away from moving parts.

### WARNING



Danger of electrical shock, explosion and fire. Improper servicing could result in dangerous operation, serious injury, death or property damage.

**READ ALL INSTRUCTIONS IN THIS MANUAL  
AND RETAIN FOR FUTURE REFERENCE**

FBR113270



### WARNING

#### FIRE OR EXPLOSION HAZARD

Failure to follow safety warnings exactly could result in serious injury, death, or property damage.



### WHAT TO DO IF YOU SMELL GAS:

- Do not try to light any appliance.
- Extinguish any open flames.
- Do not touch any electrical switch; do not use any phone in your building.
- Leave the building immediately.
- Immediately call your gas supplier from a neighbor's phone. Follow the gas supplier's instructions.
- If you cannot reach your gas supplier, call the fire department.

**Do not store or use gasoline or other flammable vapors and liquids in the vicinity of this or any other appliance.**

**Installation and service must be performed by a qualified installer, service agency or the gas supplier.**

## LG/LD 024, 036, 048, 060 Parts Arrangement

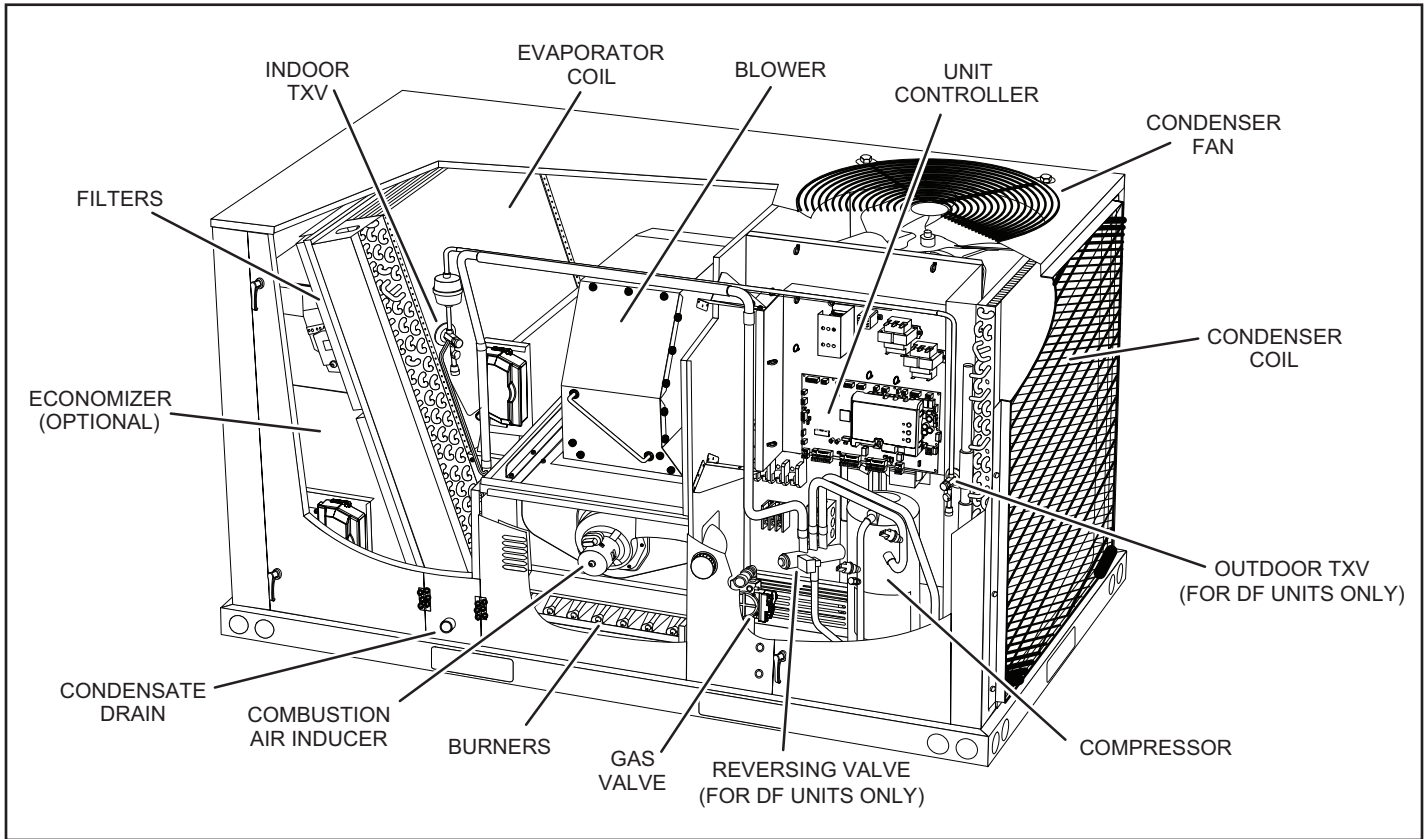

## LG/LD 078, 102, 120, 152 Parts Arrangement

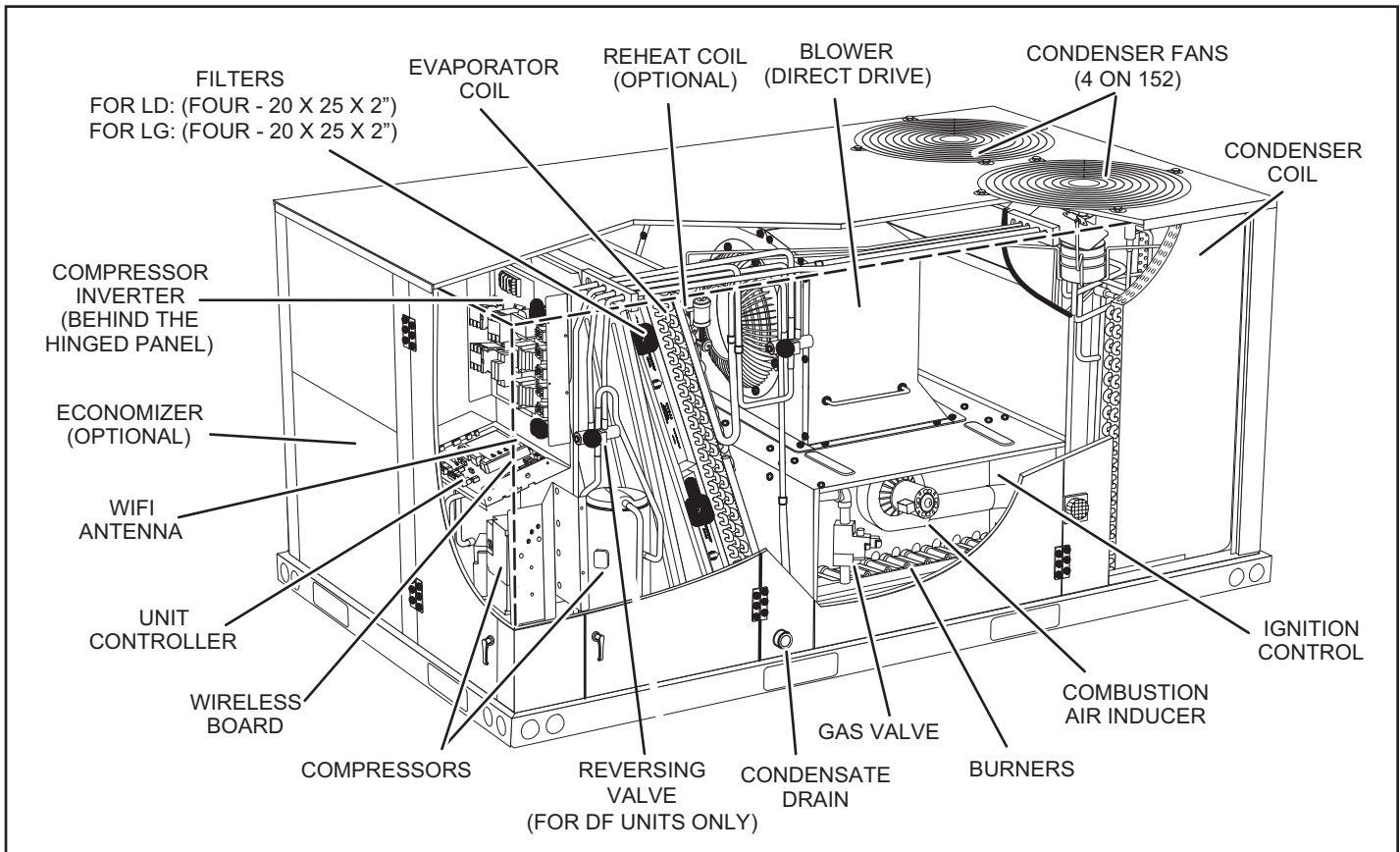

## LG 156, 180, 210, 240, 300, 302, 360 Parts Arrangement

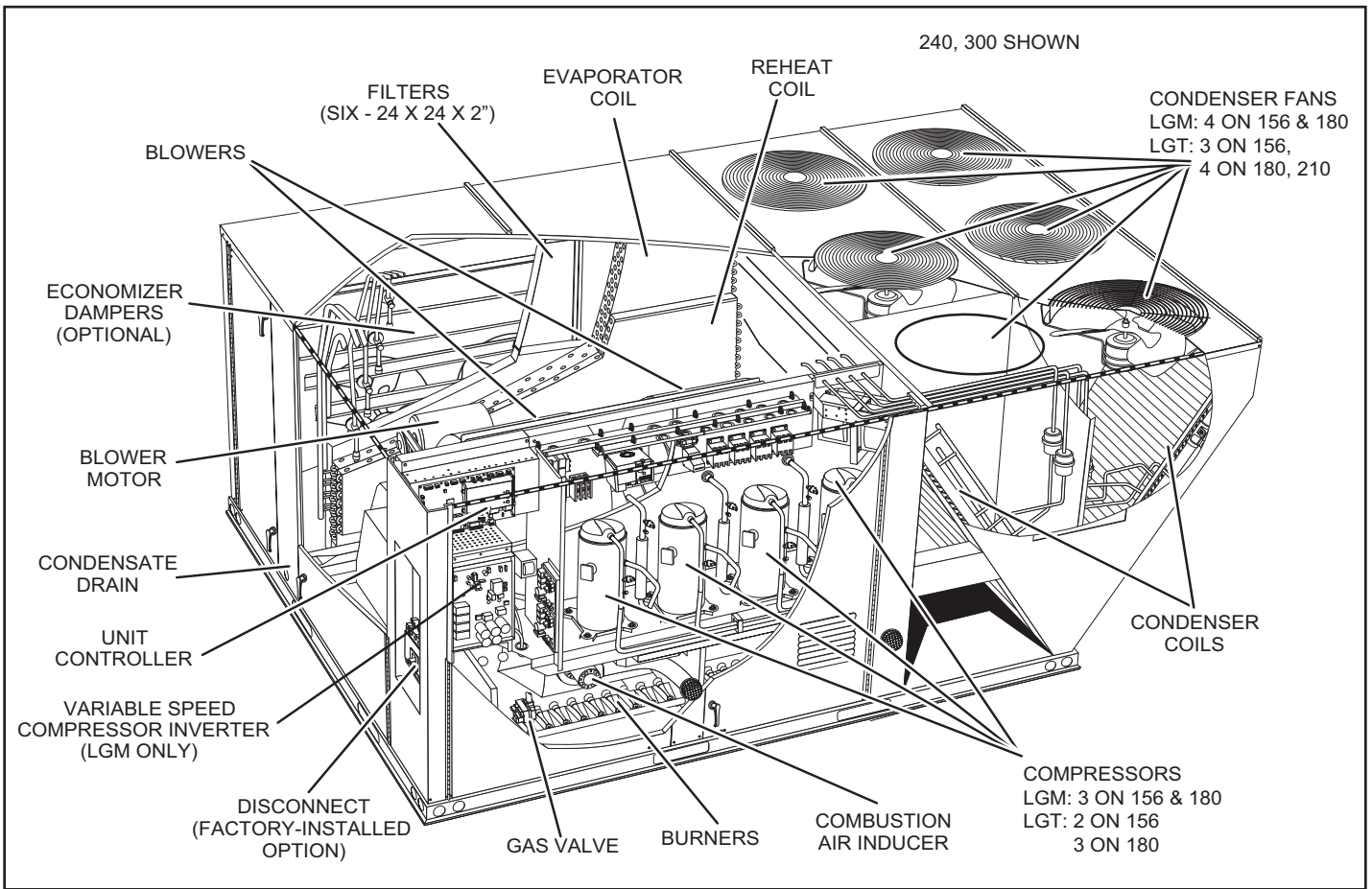

## LD 180, 240, 302 Parts Arrangement

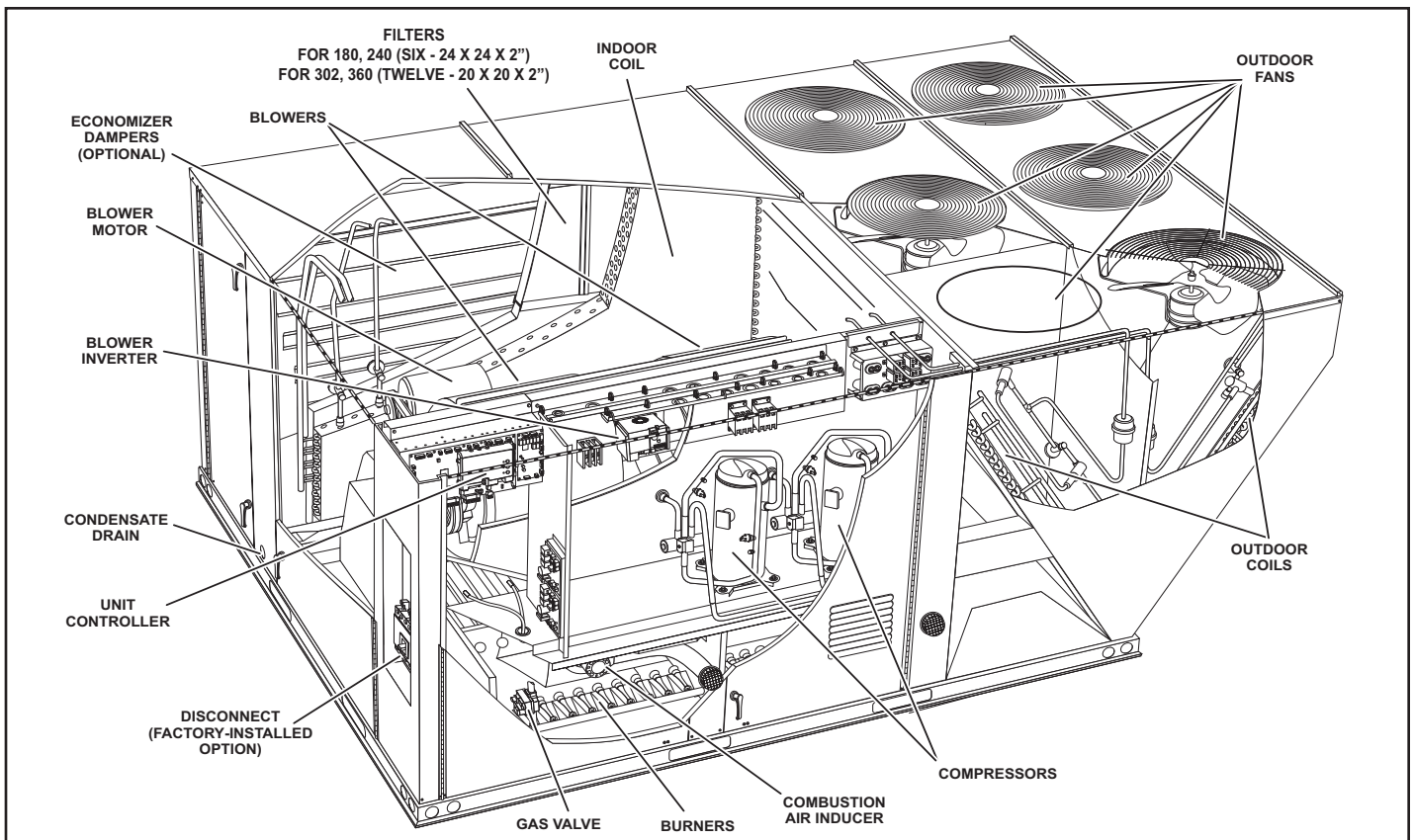

## ⚠ CAUTION

The appliance is not to be used by persons (including children) with reduced physical, sensory or mental capabilities, or lack of experience and knowledge, unless they have been given supervision or instruction

## ⚠ CAUTION

Children should be supervised not to play with the appliance.

## ⚠ CAUTION

Label all wires prior to disconnection when servicing controls. Wiring errors can cause improper and dangerous operation. Verify proper operation after servicing.

## ⚠ WARNING



Electric shock hazard. Can cause injury or death. Before attempting to perform any service or maintenance, turn the electrical power to unit OFF at disconnect switch(es). Unit may have multiple power supplies.

## ⚠ WARNING

Do not use this furnace if any part has been under water. A flood-damaged furnace is extremely dangerous. Attempts to use the furnace can result in fire or explosion. A qualified service agency should be contacted to inspect the furnace and to replace all gas controls, control system parts, electrical parts that have been wet or the furnace if deemed necessary.

## ⚠ WARNING



Danger of explosion. Can cause injury or product or property damage. If overheating occurs or if gas supply fails to shut off, shut off the manual gas valve to the appliance before shutting off electrical supply.

### Unit Operation

#### FOR YOUR SAFETY READ BEFORE LIGHTING

**BEFORE LIGHTING** smell all around the furnace area for gas. Be sure to smell next to the roof because some gas is heavier than air and will settle on the roof.

The gas valve may be equipped with either a gas control lever or gas control knob. Use only your hand to push the lever or turn the gas control knob. Never use tools. If the the lever will not move or the knob will not push in or turn by hand, do not try to repair it. Call a qualified service technician. Force or attempted repair may result in a fire or explosion.

The unit is equipped with an automatic spark ignition system. There is no pilot. In case of a safety shutdown, move thermostat switch to **OFF** and return the thermostat switch to **HEAT**. For logic units and units with electronic tempera-

ture controls, shut off the main disconnect and then turn it on to reset the ignition control.

#### Placing Unit Into Operation

## ⚠ WARNING



Danger of explosion and fire. Can cause injury or product or property damage. You must follow these instructions exactly.

#### Gas Valve Operation

- 1 - Set thermostat to lowest setting.
- 2 - Turn off all electrical power to appliance.
- 3 - This appliance is equipped with an ignition device which automatically lights the burner. Do **not** try to light the burner by hand.
- 4 - Open the heat section access panel.
- 5 - Turn gas valve switch to **OFF**. See Figure 1, Figure 2 or Figure 3.
- 6 - Wait five (5) minutes to clear out any gas. If you then smell gas, **STOP!** Immediately call your gas supplier from a neighbor's phone. Follow the gas supplier's instructions. If you do not smell gas, go to the next step.

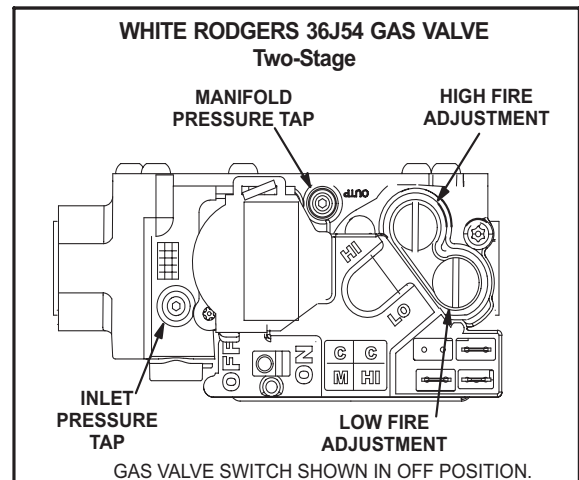

FIGURE 1

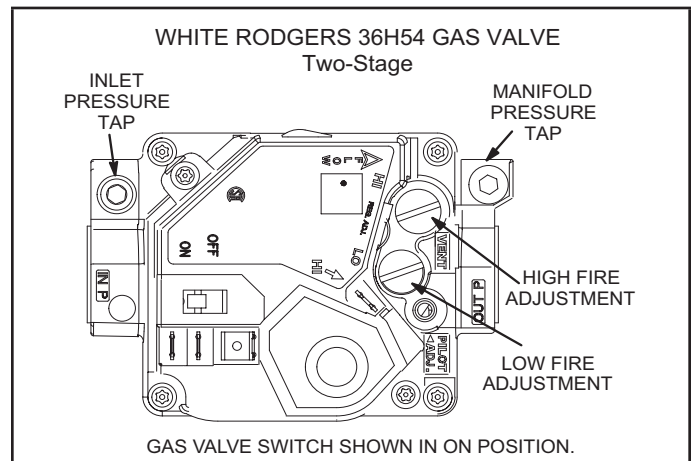
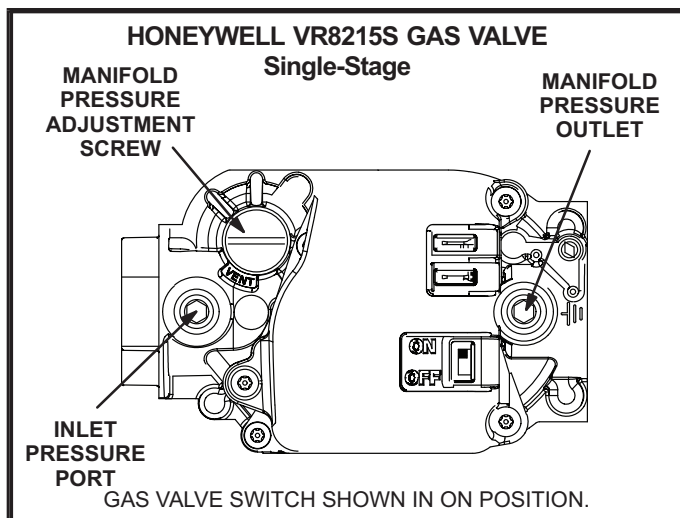

FIGURE 2



**FIGURE 3**

- 7 - Turn gas valve switch to **ON**. See Figure 1, Figure 2 or Figure 3.
- 8 - Close or replace the heat section access panel.
- 9 - Turn on all electrical power to appliance.
- 10 - Set thermostat to desired setting.

**NOTE** - When unit is initially started, steps 1 through 9 may need to be repeated to purge air from gas line.

- 11 - The ignition sequence will start.
- 12 - If the appliance does not light the first time (gas line not fully purged), it will attempt up to two more ignitions before locking out.
- 13 - If lockout occurs, repeat steps 1 through 10.
- 14 - If the appliance will not operate, follow the instructions "Turning Off Gas to Appliance" and call your service technician or gas supplier.

#### Turning Off Gas to Unit

- 1 - If using an electromechanical thermostat, set to the lowest setting.
- 2 - Before performing any service, turn off all electrical power to the appliance.
- 3 - Open or remove the heat section access panel.
- 4 - Turn gas valve switch to **OFF**.
- 5 - Close or replace the heat section access panel.

<b>⚠ WARNING</b>
<b>Danger of explosion. Can cause injury or death. Do not attempt to light manually. Unit has a direct spark ignition system.</b>

#### Burner Flame

<b>⚠ WARNING</b>
<b>Danger of explosion and fire. Can cause injury or product or property damage. Periodically inspect burner flame to ensure proper unit operation.</b>

#### Non-ULNOx Units

The primary air is permanently set for normal operation. The flame will be basically blue with some clear yellow streaking in the end of the flame. Inspect the burner flame periodically during the heating season using the inspection port provided on the burner access panel.

#### ULNOx Units

ULNOx units are not equipped with gas orifices that supply each burner. Instead, a single gas orifice supplies gas to the air/gas elbow. An intake air orifice supplies combustion air to the air/gas elbow. The combustion air blower draws the air/gas mixture from the air/gas elbow into the air/gas plenum box. When the spark ignites the gas, the ignition sensor proves the flame and combustion occurs in the burner premix plate. The burner box liner directs the flames into the burner tube sleeves. Refer to Figure 4.

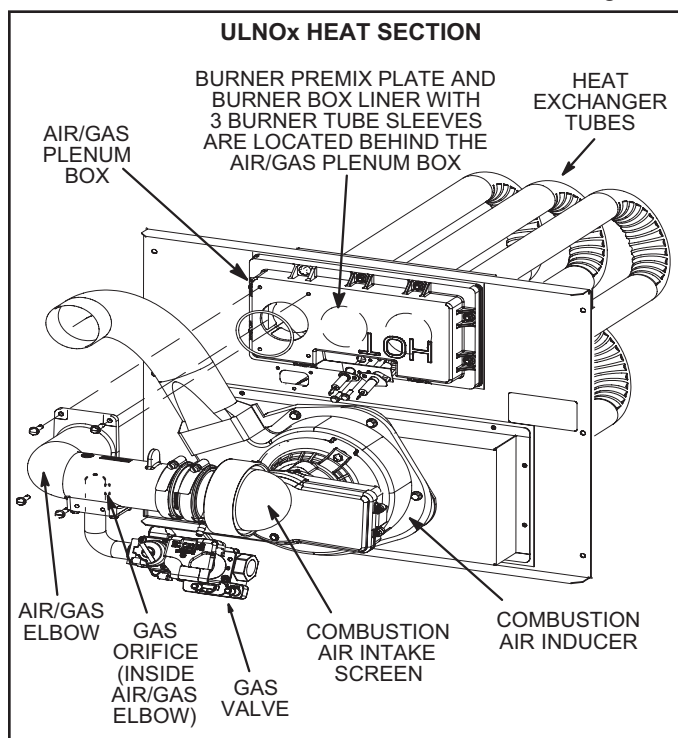

**FIGURE 4**

## Flue Passage and Vent Inspection

Annually, before heating season, inspect the combustion air louvers, vent cap, heat exchanger, burners (non-UL-NOx units only), and combustion air inducer for corrosion, deterioration or deposits of debris. Remove any obstructions or blockage. On UNLOx units, periodically clean lint or other debris from the combustion air intake screen. See Figure 4, Figure 5, Figure 6, or Figure 7.

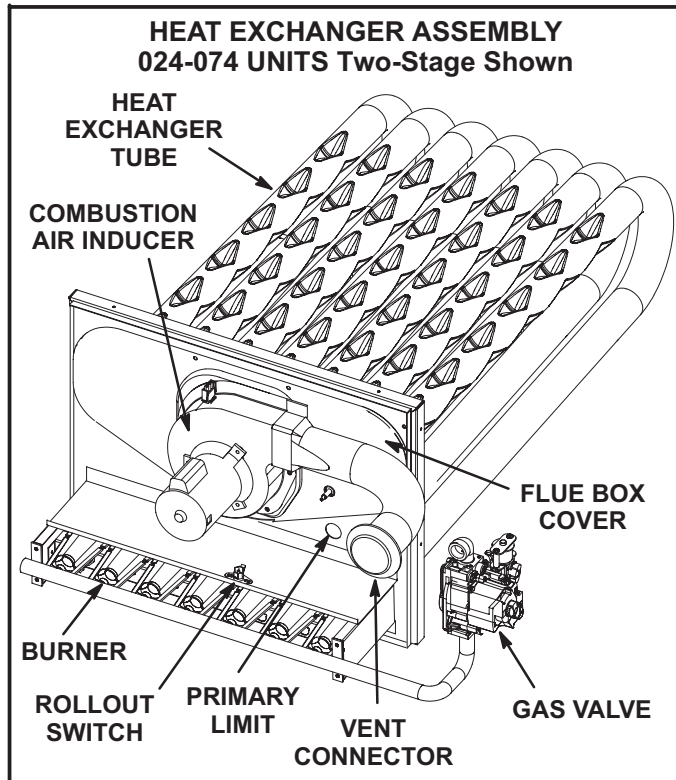

FIGURE 5

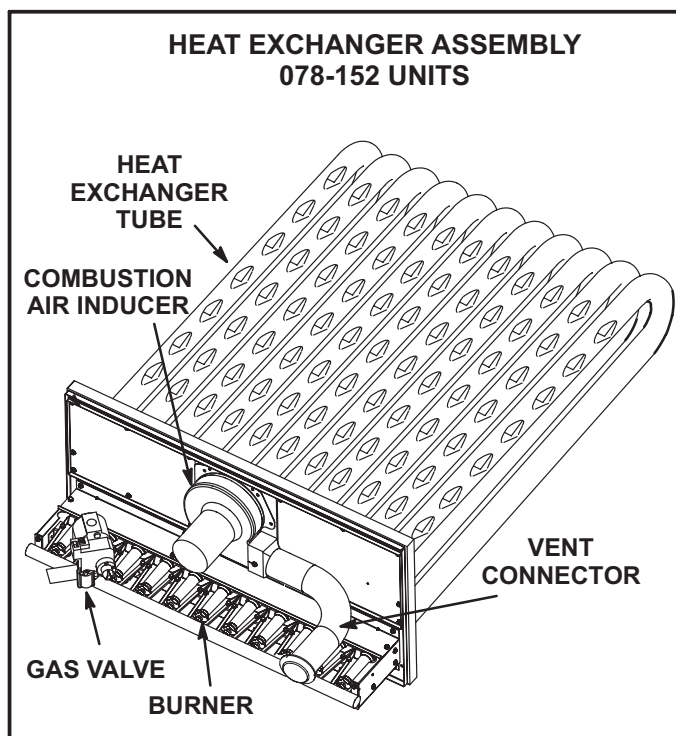

FIGURE 6

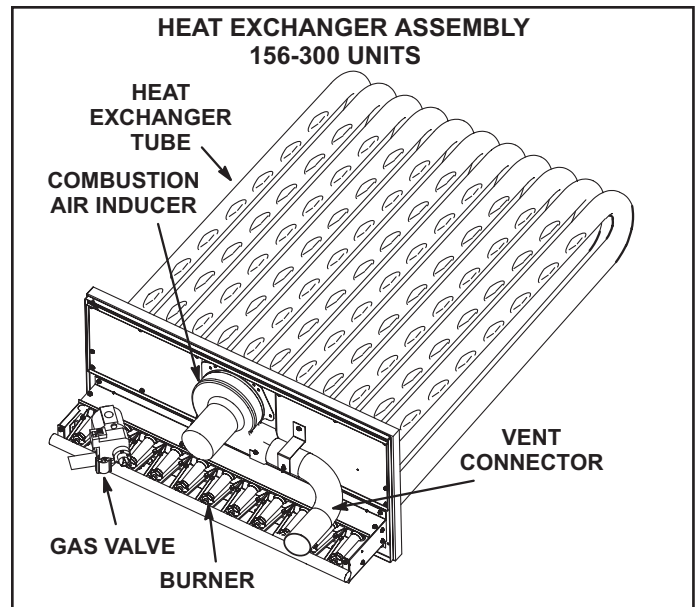

FIGURE 7

## Service

To maintain efficiency and longevity, your equipment must be serviced yearly by a qualified service technician. Failure to provide proof of service can void warranty.

### **CAUTION**

Label all wires prior to disconnection when servicing controls. Wiring errors can cause improper and dangerous operation. Verify proper operation after servicing.

## Servicing Filter

Units are equipped with filters as shown in TABLE 1. Filters should be checked monthly and replaced when necessary. Take note of air flow direction marking on filter frame when reinstalling filters. See Figure 8.

**NOTE** - Replace factory-installed filters within 30 days of initial unit start-up. Refer to local codes or appropriate jurisdiction for approved filters.

### **WARNING**

Units are shipped from the factory with temporary filters. Replace filters before building is occupied. Damage to unit could result if filters are not replaced with approved filters. Refer to appropriate codes.

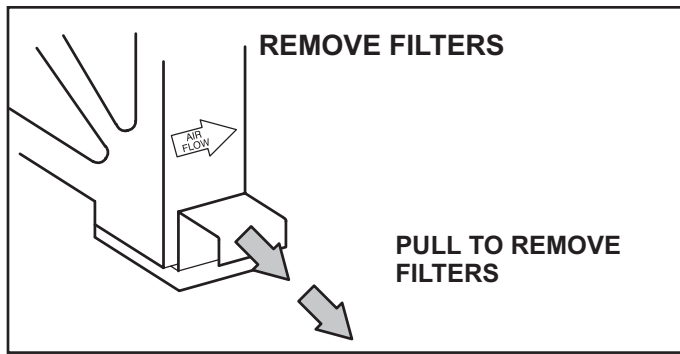

**FIGURE 8**

**TABLE 1  
UNIT FILTERS**

Unit	Qty	Filter Size - inches (mm)
024 - 074	4	20 X 20 X 2 (508 X 508 X 51)
078 - 152	4	20 X 25 X 2 (508 X 635 X 51)
156 - 300	6	24 X 24 X 2 (610 X 610 X 51)
242, 302, 360	12	20 X 20 X 2 (508 X 808 X 51)

**NOTE** - Filters must be ULC approved or equivalent for use in Canada.

**Lubrication**

All motors are lubricated at the factory. No further lubrication is required.

*156-300 Units -*

Blower shaft bearings are prelubricated. For extended bearing life, relubricate at least once every two years with a lithium base grease, such as Alvania 3 (Shell Oil), Chevron BRB2 (Standard Oil) or Regal AFB2 (Texas Oil). Use a hand grease gun for relubrication. Add only enough grease to purge through the bearings so that a bead of grease appears at the seal lip contacts.

**Manifold Pressures - Non-ULNOx Units**

Manifold pressures are shown in TABLE 2. Refer to Figure 1 or Figure 2 to locate pressure ports.

**TABLE 2  
MANIFOLD PRESSURES in.w.g**

Unit	Natural Gas		Propane (LP) Gas	
	1st Stg ± 0.2	2nd Stg ± 0.3	1st Stg ± 0.2	2nd Stg ± 0.3
024,036, 048, 060, 072, 074 Dual Heat	2.0 (0.47)	3.5 (0.87)	5.9 (1.47)	10.5 (2.61)
078-360	1.6 (0.40)	3.7 (0.92)	5.5 (1.47)	10.5 (2.61)

**Burners - Non-ULNOx Units**

Clean the burners as follows:

- 1 - Turn off the electrical power and the gas supply to the unit.
- 2 - Remove the burner compartment access panel.
- 3 - Remove top burner box panel. See Figure 9 or Figure 10.
- 4 - Remove screws securing burners to burner support and lift the entire burner assembly from the orifices. Clean as necessary. Spark gap on ignition electrode must be properly set. Refer to the Heating Adjustment section in the installation instructions.
- 5 - Replace burners and screws securing burner. Replace the top burner box panel.
- 6 - Turn on the electrical power and the gas supply to the unit. Follow the operating instructions attached to the unit and use the inspection port in the access panel to check the flame.

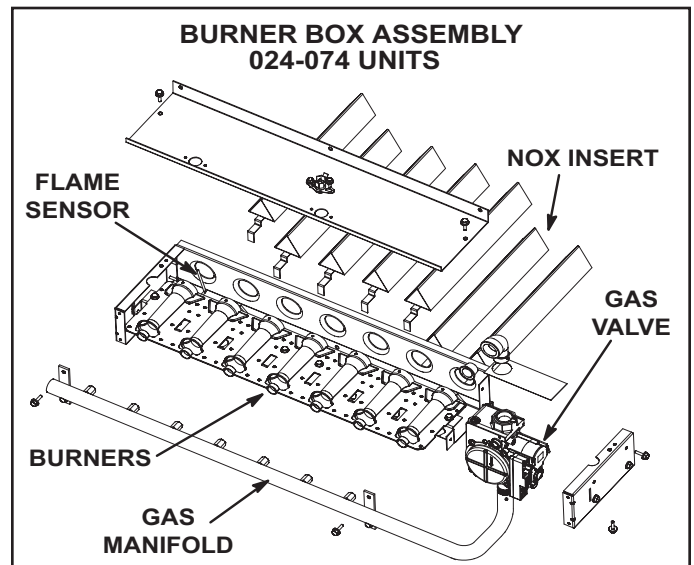

**FIGURE 9**

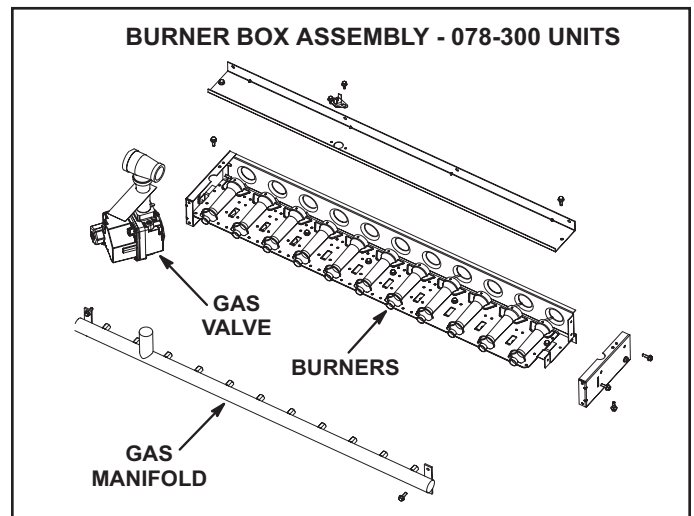

**FIGURE 10**

## Combustion Air Inducer

A combustion air inducer proving switch checks combustion air inducer operation before allowing power to the gas controller. The gas controller will not operate if the inducer is obstructed.

Under normal operating conditions, the combustion air inducer wheel should be checked and cleaned prior to the heating season. However, it should be examined periodically during the heating season to establish an ideal cleaning schedule.

Clean the combustion air inducer as follows:

- 1 - Turn off the electrical power and the gas supply to the unit.
- 2 - On 078-152 units, remove the mullion on the right side of the heat section. On 156-360 units, remove the tube bracket support on the right side of the heat section.
- 3 - Disconnect the pressure switch air tubing from the combustion air inducer port.
- 4 - Remove and retain the screws securing the combustion air inducer to the flue box.
- 5 - Clean the inducer wheel blades with a small brush and wipe off any dust from the housing. Clean accumulated dust from the front of the flue box cover.
- 6 - Return the combustion air inducer motor and the vent connector to their original location. Secure with retained screws. It is recommended that the

combustion air inducer gasket be replaced during reassembly.

- 7 - On 078-152 units, replace the mullion. On 156-360 units, replace the tube bracket support.

- 8 - Use a small brush to clean the combustion air inlet louvers on the heat access panel.

## Flue Passageway and Flue Box

- 1 - Remove the combustion air inducer assembly as described in the Combustion Air Inducer subsection.
- 2 - Remove the flue box cover. Clean the flue box with a wire brush as required.
- 3 - Clean the tubes with a wire brush.
- 4 - Reassemble the unit. The flue box cover gasket and combustion air inducer gasket should also be replaced during reassembly.

## Service Reminder

Call a qualified service technician if the unit is inoperative. Before calling, always check the following to be sure service is required:

- 1 - Be sure electrical disconnect switches are **ON**.
- 2 - Check room thermostat for proper setting.
- 3 - Replace any blown fuses or reset circuit breakers.
- 4 - Gas valve should be **ON**.
- 5 - Air filters should not be plugged, limiting air flow.
- 6 - Make sure all access panels are in place.

## Repair Parts Listing

When ordering repair parts, include the complete model number and serial number listed on the ETL/CSA rating plate - e.g. LGM120U4EH1Y.

### Gas Heat Section Parts

Heat Exchanger  
Combustion Air Assembly  
Combustion Air Proving Switch  
Burner Assembly  
Burner Manifold Assembly  
Main Burner Orifices  
Flame Roll-out Switches  
Auxiliary Limit Controls  
Ignition Electrode Assembly  
Ignition Lead  
Ignition Sensor Assembly  
Sensor Lead  
Combination Gas Valve  
Limit Controls  
Ignition Controller

### Cooling Parts

Compressors  
Condenser Fan Motors  
Condenser Fan Blades  
Condenser Fan Run Capacitors\*  
\*Used only with PSC motor applications  
Condenser Fan Mounting Bracket  
Fan Grille  
Indoor Blower Motors  
Blower Wheel  
Expansion Valve  
Distributor  
Exhaust Fans (Opt.)  
Reversing Valve (LD and reheat units only)

### Electrical Control Parts

Unit Controller  
Compressor Contactors  
Circuit Breakers (Opt.)  
Transformer (Control)  
Transformer (Contactor)  
Blower Contactor  
Limit, Blower Relay  
Heat Relays  
Condenser Fan Relays  
Capacitor CAB  
Relay CAB  
Disconnect Switch (Opt.)  
Defrost Control (LD only)  
Fan Control Board (LD only)

### ULNOx Units

Intake Air Screen  
Intake Air Orifice  
Air/Gas Elbow  
Air/Gas Plenum Box  
Burner Premix Plate  
Burner Box Liner and Tubes  
Inlet Reducer  
Rubber Coupling



©2022 Lennox Industries Inc.  
Dallas, Texas, USA



**THIS MANUAL MUST BE LEFT WITH THE HOMEOWNER FOR FUTURE REFERENCE**

### **⚠ WARNING**

Improper installation, adjustment, alteration, service or maintenance can cause property damage, personal injury or loss of life. Installation and service must be performed by a licensed professional HVAC installer or equivalent, or service agency.

### **⚠ WARNING**

To prevent serious injury or death:

1. Lock-out/tag-out before performing maintenance.
2. If system power is required (e.g., smoke detector maintenance), disable power to blower, remove fan belt where applicable, and ensure all controllers and thermostats are set to the "OFF" position before performing maintenance.
3. Always keep hands, hair, clothing, jewelry, tools, etc. away from moving parts.

# INSTALLATION INSTRUCTIONS

## Merit® Series ML17XP1 Units

HEAT PUMP  
508263-01  
6/2022

### General

This ML17XP1 outdoor heat pump **with all-aluminum coil** is designed for use with HFC-410A refrigerant only. This unit must be installed with an approved indoor air handler or coil. For AHRI Certified system match-ups and expanded ratings, visit [www.LennoxPros.com](http://www.LennoxPros.com). These instructions are intended as a general guide and do not supersede local codes in any way. Consult authorities having jurisdiction before installation.

### NOTICE!

Charging information is given on the charging procedure sticker on the unit access panel. For more in-depth information, consult the Installation and Service Procedures manual, available on [LennoxPros.com](http://LennoxPros.com) or through the Technical Support department at 800-453-6669.

### ⚠ CAUTION

As with any mechanical equipment, contact with sharp sheet metal edges can result in personal injury. Take care while handling this equipment and wear gloves and protective clothing.

**IMPORTANT:** Special procedures are required for cleaning the all-aluminum coil in this unit. See page 15 in this instruction for information.

## STEP 1 – SETTING THE UNIT – Clearances

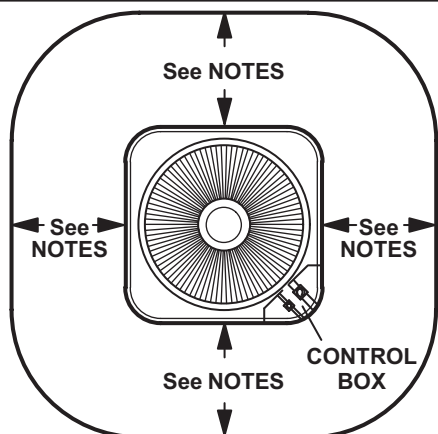

### NOTES -

Service clearance of 30 in. (762 mm) must be maintained on one of the sides adjacent to the control box.

Clearance to one of the other three sides must be 36 in. (914 mm).

Clearance to one of the remaining two sides may be 12 in. (305 mm) and the final side may be 6 in. (152 mm).

A clearance of 24 in. must be maintained between two units.

48 in. (1219 mm) clearance required on top of unit.



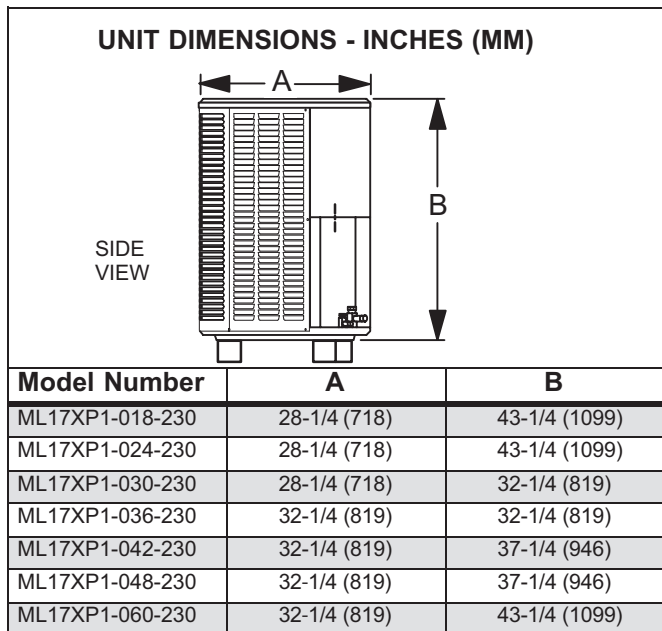

**FIGURE 1. Unit Dimensions**

**STEP 1 – SETTING THE UNIT  
(Continued) – Unit Placement**

**NOTICE!**

**Roof Damage!**  
This system contains both refrigerant and oil. Some rubber roofing material may absorb oil, causing the rubber to degrade. Failure to follow this notice could result in damage to roof surface.

**! IMPORTANT**

This unit must be matched with an indoor coil as specified with AHRI. For AHRI Certified system match-ups and expanded ratings, visit [www.LennoxPros.com](http://www.LennoxPros.com). Coils previously charged with HCFC-22 must be flushed.

**! WARNING**

To prevent personal injury, as well as damage to panels, unit or structure, observe the following:  
While installing or servicing this unit, carefully stow all removed panels so that the panels will not cause injury to personnel, objects or nearby structures. Also, take care to store panels where they will not be subject to damage (e.g., being bent or scratched).  
While handling or stowing the panels, consider any weather conditions (especially wind) that may cause panels to be blown around and damaged.

**! IMPORTANT**

The Clean Air Act of 1990 bans the intentional venting of refrigerant (CFCs, HCFCs and HFCs) as of July 1, 1992. Approved methods of recovery, recycling or reclaiming must be followed. Fines and/or incarceration may be levied for noncompliance.

**! IMPORTANT**

Exhaust vents from dryers, water heaters and furnaces should be directed away from the outdoor unit. Prolonged exposure to exhaust gases and the chemicals contained within them may cause condensation to form on the steel cabinet and other metal components of the outdoor unit. This will diminish unit performance and longevity

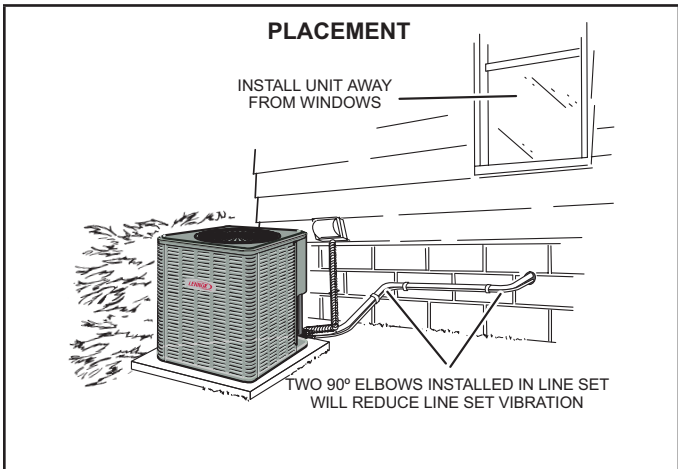

**FIGURE 2**

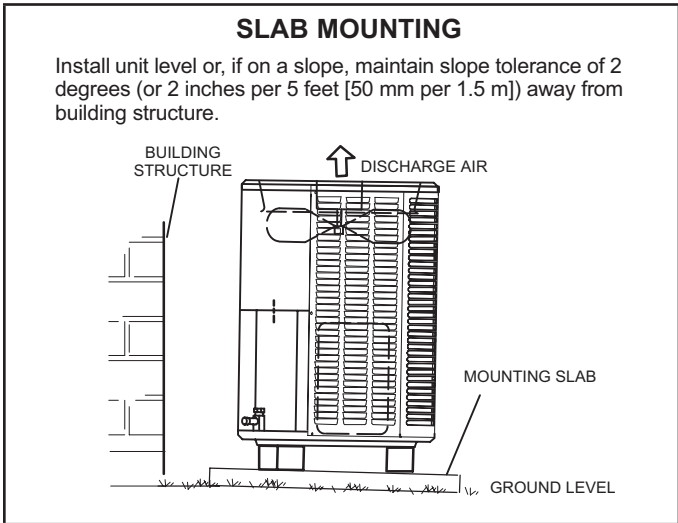

**FIGURE 3**

**! IMPORTANT**

This model is designed for use in check / expansion valve systems only. An indoor expansion valve approved for use with HFC-410A refrigerant must be ordered separately and installed prior to operating the system.

**NOTE** - An optional Unit Stand-Off Kit (94J45) is available for this unit. Black high-density polyethylene feet raise unit off of mounting surface away from damaging moisture. Four feet are furnished per order number.

## STEP 2 – REFRIGERANT PIPING

### IMPORTANT

If this unit is being matched with an approved line set or indoor unit coil that was previously charged with mineral oil, or if it is being matched with a coil which was manufactured before January of 1999, the coil and line set must be flushed prior to installation. Take care to empty all existing traps. Polyol ester (POE) oils are used in Lennox units charged with HFC-410A refrigerant. Residual mineral oil can act as an insulator, preventing proper heat transfer. It can also clog the expansion device and reduce system performance and capacity. Failure to properly flush the system per this instruction and the detailed Installation and Service Procedures manual will void the warranty.

Flush the existing line set per the following instructions. For more information, refer to the Installation and Service Procedures manual available on LennoxPros.com. CAUTION - DO NOT attempt to flush and re-use existing line sets or indoor coil when the system contains contaminants (i.e., compressor burn out).

If a new line set is being installed, size the piping per table 1.

TABLE 1

REFRIGERANT LINE SET – INCHES (MM)					
Model	Valve Field Connections		Recommended Line Set		
	Liquid Line	Vapor Line	Liquid Line	Vapor Line	L15 Line Sets
-018	3/8 in. (10 mm)	3/4 in. (19 mm)	3/8 in. (10 mm)	3/4 in. (19 mm)	L15-41 15 ft. - 50 ft. (4.6 m - 15 m)
-024					
-030					
-036	3/8 in. (10 mm)	7/8 in. (22 mm)	3/8 in. (10 mm)	7/8 in. (22 mm)	L15-65 15 ft. - 50 ft. (4.6 m - 15 m)
-042					
-048					
-060	3/8 in. (10 mm)	1-1/8 in. (28 mm)	3/8 in. (10 mm)	1-1/8 in. (28 mm)	Field Fabricated

NOTE - Some applications may require a field-provided 7/8" to 1-1/8" adapter.

**NOTE** - When installing refrigerant lines longer than 50 feet, refer to the Refrigerant Piping Design and Fabrication Guidelines manual available on LennoxPros.com (Corp. 9351-L9), or contact the Technical Support Department Product Application group for assistance.

**NOTE** - For new or replacement line set installation, refer to Service and Application Note - Corp. 9112-L4 (C-91-4).

### WARNING



When using a high pressure gas such as nitrogen to pressurize a refrigeration or air conditioning system, use a regulator that can control the pressure down to 1 or 2 psig (6.9 to 13.8 kPa).

### WARNING

Refrigerant can be harmful if it is inhaled. Refrigerant must be used and recovered responsibly. Failure to follow this warning may result in personal injury or death.

### WARNING



Fire, Explosion and Personal Safety hazard. Failure to follow this warning could result in damage, personal injury or death. Never use oxygen to pressurize or purge refrigeration lines. Oxygen, when exposed to a spark or open flame, can cause fire and/or an explosion, that could result in property damage, personal injury or death.

### WARNING

Polyol ester (POE) oils used with HFC-410A refrigerant absorb moisture very quickly. It is very important that the refrigerant system be kept closed as much as possible. DO NOT remove line set caps or service valve stub caps until you are ready to make connections.

### IMPORTANT

Some scroll compressors have an internal vacuum protector that will unload scrolls when suction pressure goes below 20 psig. A hissing sound will be heard when the compressor is running unloaded. Protector will reset when low pressure in system is raised above 40 psig. DO NOT REPLACE COMPRESSOR.

## STEP 2 – REFRIGERANT PIPING – (Continued)

### 1A TYPICAL EXISTING FIXED ORIFICE REMOVAL PROCEDURE (UNCASED COIL SHOWN)

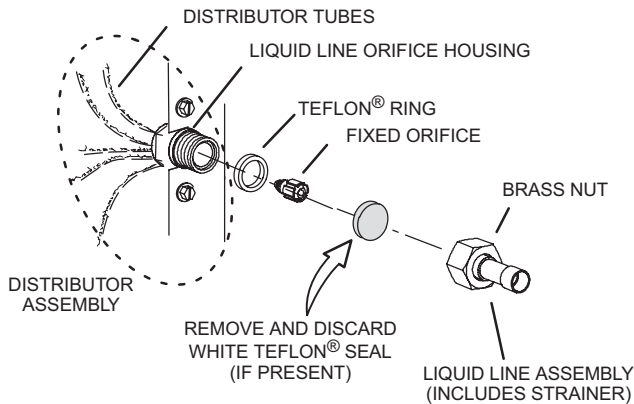

- A - On fully cased coils, remove the coil access and plumbing panels.
- B - Remove any shipping clamps from the liquid line and distributor assembly.
- C - Using two wrenches, disconnect liquid line from liquid line orifice housing. Take care not to twist or damage distributor tubes during this process.
- D - Remove and discard fixed orifice, valve stem assembly (if present) and Teflon® washer as illustrated above.
- E - Use a field-provided fitting to temporarily reconnect the liquid line to the indoor unit's liquid line orifice housing.

### OR 1B TYPICAL EXISTING EXPANSION VALVE REMOVAL PROCEDURE (UNCASED COIL SHOWN)

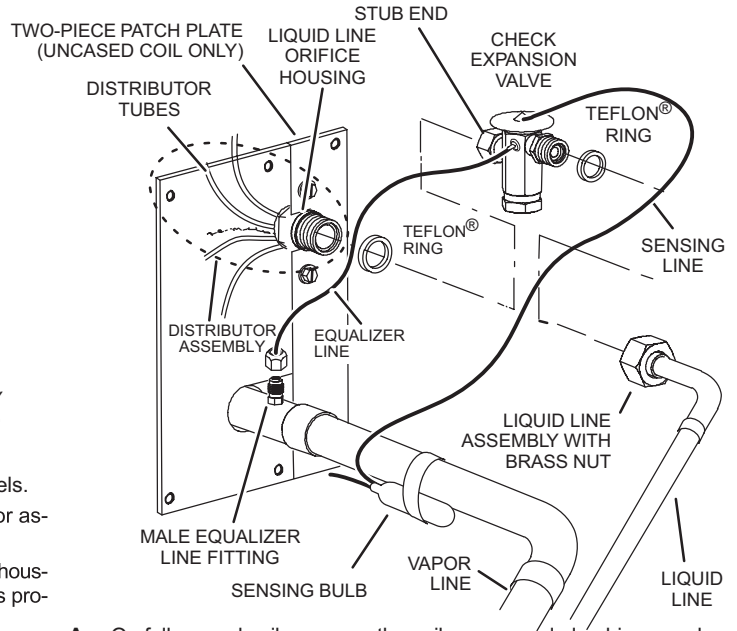

- A - On fully cased coils, remove the coil access and plumbing panels.
- B - Remove any shipping clamps from the liquid line and distributor assembly.
- C - Disconnect the equalizer line from the check expansion valve equalizer line fitting on the vapor line.
- D - Remove the vapor line sensing bulb.
- E - Disconnect the liquid line from the check expansion valve at the liquid line assembly.
- F - Disconnect the check expansion valve from the liquid line orifice housing. Take care not to twist or damage distributor tubes during this process.
- G - Remove and discard check expansion valve and the two Teflon® rings.
- H - Use a field-provided fitting to temporarily reconnect the liquid line to the indoor unit's liquid line orifice housing.

### 2 CONNECT GAUGES AND EQUIPMENT FOR FLUSHING PROCEDURE

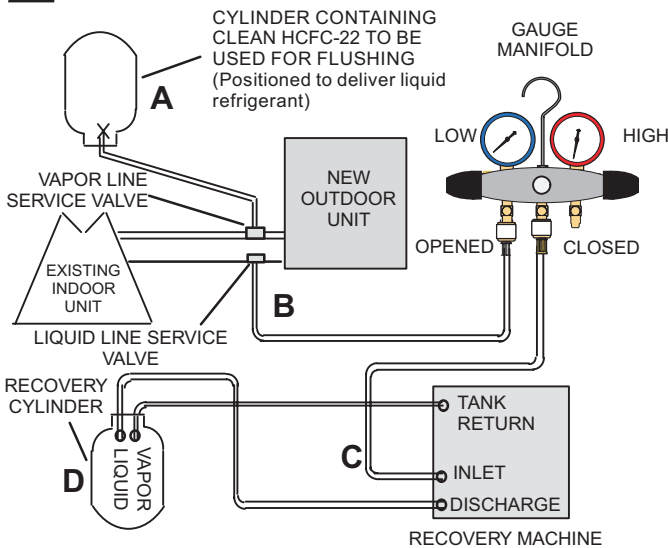

- A - HCFC-22 cylinder with clean refrigerant (positioned to deliver liquid refrigerant) to the vapor service valve.
- B - HCFC-22 gauge set (low side) to the liquid line valve.
- C - HCFC-22 gauge set center port to inlet on the recovery machine with an empty recovery tank connected to the gauge set.
- D - Connect recovery tank to recovery machine per machine instructions.

### 3 FLUSHING LINE SET

The line set and indoor unit coil must be flushed with at least the same amount of clean refrigerant that previously charged the system. Check the charge in the flushing cylinder before proceeding.

- A - Set the recovery machine for liquid recovery and start the recovery machine. Open the gauge set valves to allow the recovery machine to pull a vacuum on the existing system line set and indoor unit coil.
- B - Position the cylinder of clean HCFC-22 for delivery of liquid refrigerant and open its valve to allow liquid refrigerant to flow into the system through the vapor line valve. Allow the refrigerant to pass from the cylinder and through the line set and the indoor unit coil before it enters the recovery machine.
- C - After all of the liquid refrigerant has been recovered, switch the recovery machine to vapor recovery so that all of the HCFC-22 vapor is recovered. Allow the recovery machine to pull the system down to 0.
- D - Close the valve on the inverted HCFC-22 drum and the gauge set valves. Pump the remaining refrigerant out of the recovery machine and turn the machine off.

FIGURE 4

## STEP 2 – REFRIGERANT PIPING – Brazing Procedures

### 1 CUT AND DEBUR

Cut ends of the refrigerant lines square (free from nicks or dents) and debur the ends. The pipe must remain round. Do not crimp end of the line.

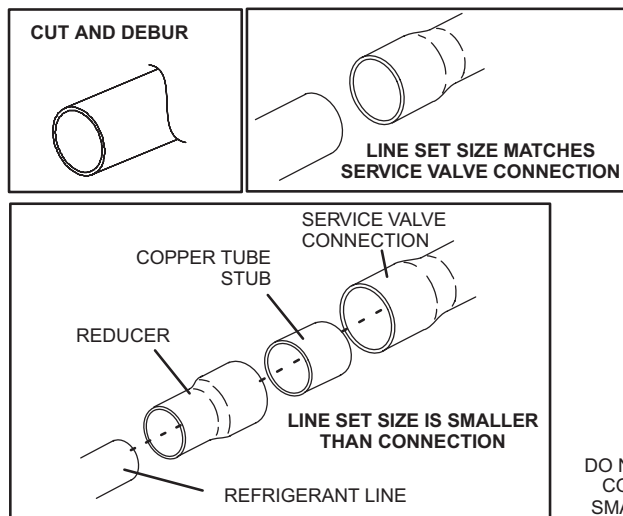

### 2 CAP AND CORE REMOVAL

Remove service cap and core from both the vapor and liquid line service ports.

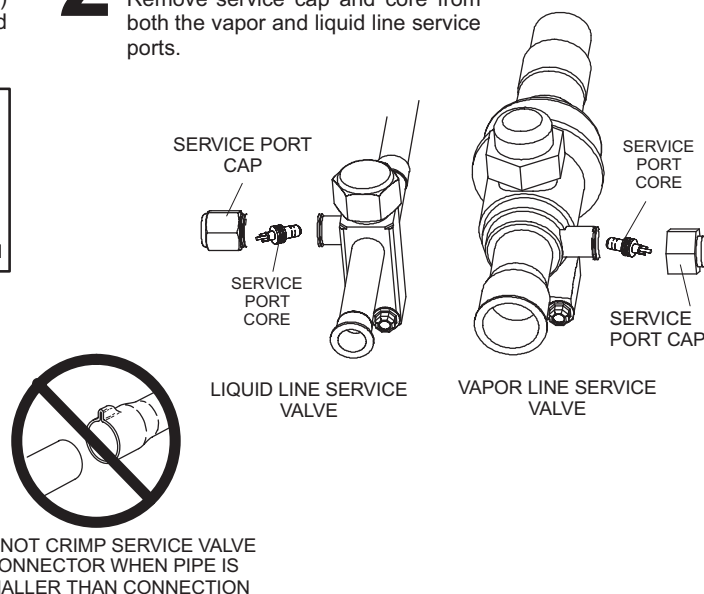

### 3 ATTACH THE MANIFOLD GAUGE SET FOR BRAZING LIQUID AND VAPOR LINE SERVICE VALVES

Flow regulated nitrogen (at 1 to 2 psig) through the low-side refrigeration gauge set into the liquid line service port valve, and out of the vapor line service port valve.

- A - Connect gauge set low pressure side to liquid line service valve (service port).
- B - Connect gauge set center port to bottle of nitrogen with regulator.
- C - Remove core from valve in vapor line service port to allow nitrogen to escape.

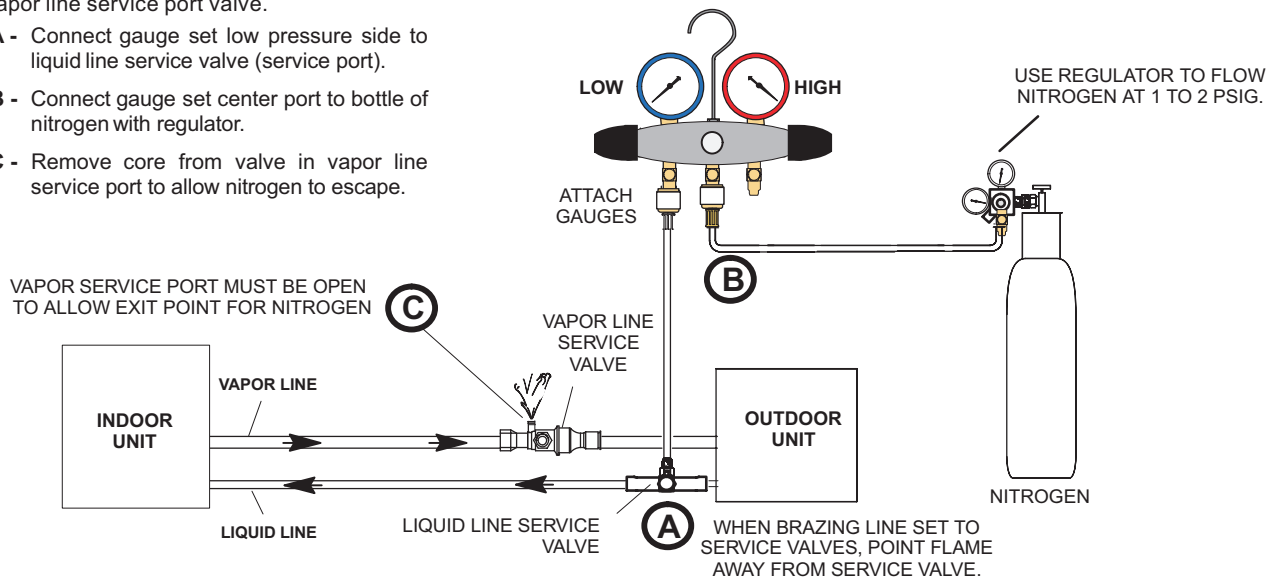

FIGURE 5

### ⚠ CAUTION

Brazing alloys and flux contain materials which are hazardous to your health. Avoid breathing vapors or fumes from brazing operations. Perform operations only in well-ventilated areas. Wear gloves and protective goggles or face shield to protect against burns. Wash hands with soap and water after handling brazing alloys and flux.

### ⚠ WARNING



Danger of fire. Bleeding the refrigerant charge from only the high side may result in pressurization of the low side shell and suction tubing. Application of a brazing torch to a pressurized system may result in ignition of the refrigerant and oil mixture. Check the high and low pressures before applying heat.

## 4 WRAP SERVICE VALVES

To help protect service valve seals during brazing, wrap water-saturated cloths around service valve bodies and copper tube stubs. Use additional water-saturated cloths underneath the valve body to protect the base paint.

## 5 FLOW NITROGEN

Flow regulated nitrogen (at 1 to 2 psig) through the refrigeration gauge set into the valve stem port connection on the liquid service valve and out of the vapor valve stem port. See steps 3A, 3B and 3C on manifold gauge set connections.

## 6 BRAZE LINE SET

Wrap both service valves with water-saturated cloths as illustrated here and as mentioned in step 4, before brazing to line set. Cloths must remain water-saturated throughout the brazing and cool-down process.

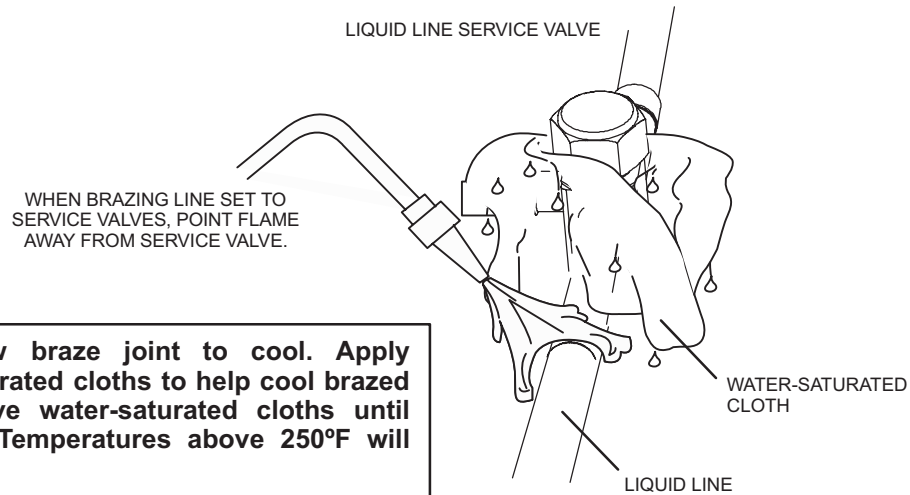

**IMPORTANT — Allow braze joint to cool. Apply additional water-saturated cloths to help cool brazed joint. Do not remove water-saturated cloths until piping has cooled. Temperatures above 250°F will damage valve seals.**

### WARNING



**FIRE, PERSONAL INJURY, OR PROPERTY DAMAGE** may result if you do not wrap a water-saturated cloth around both liquid and suction line service valve bodies and copper tube stub while brazing the line set! The braze, when complete, must be quenched with water to absorb any residual heat.



Do not open service valves until refrigerant lines and indoor coil have been leak-tested and evacuated. Refer to Installation and Service Procedures manual found on [LennoxPros.com](http://LennoxPros.com).

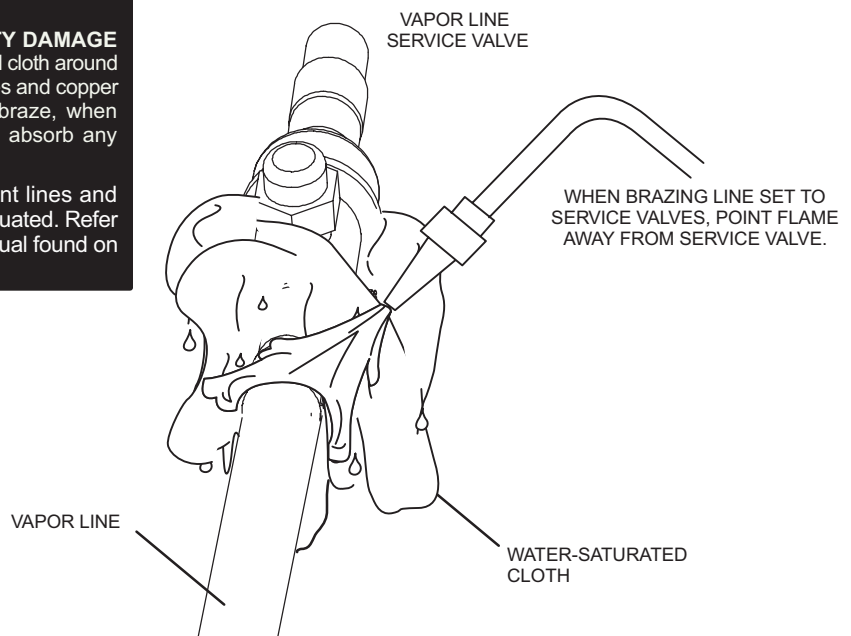

## 7 PREPARATION FOR NEXT STEP

After all connections have been brazed, disconnect manifold gauge set from service ports. Apply additional water-saturated cloths to both services valves to cool piping. Once piping is cool, remove all water-saturated cloths.

FIGURE 6

## STEP 2 – REFRIGERANT PIPING – Install Indoor Expansion Valve

This outdoor unit is designed for use in systems that include an expansion valve metering device (purchased separately) at the indoor coil. See the ML17XP1 Product Specifications bulletin (EHB) for approved expansion valve kit match-ups and application information. The check expansion valve unit can be installed internal or external to the indoor coil. In applications where an uncased coil is being installed in a field-provided plenum, install the check/expansion valve in a manner that will provide access for future field service of the expansion valve. Refer to below illustration for reference during installation of expansion valve unit.

### INDOOR EXPANSION VALVE INSTALLATION

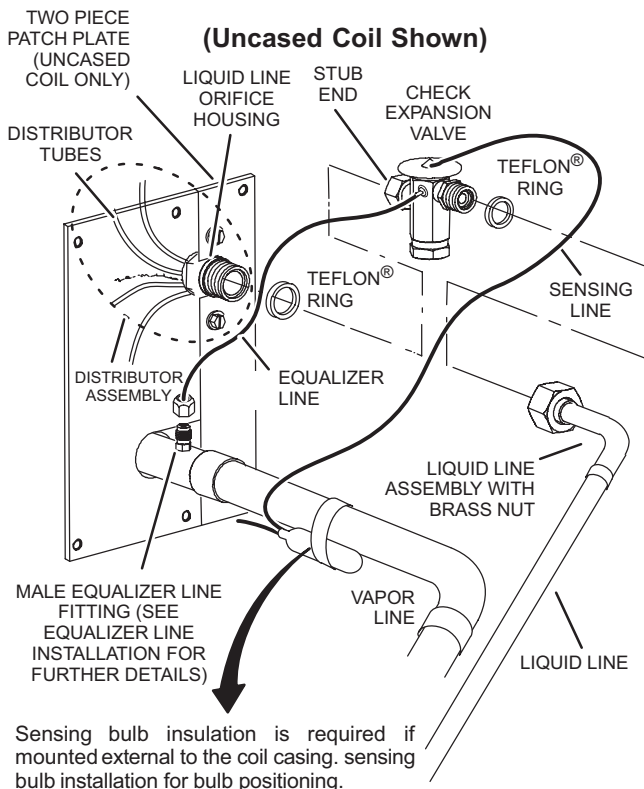

- 3 - Install one of the provided Teflon® rings around the stubbed end of the check expansion valve and lightly lubricate the connector threads and expose surface of the Teflon® ring with refrigerant oil.
- 4 - Attach the stubbed end of the check expansion valve to the liquid line orifice housing. Finger tighten and use an appropriately sized wrench to turn an additional 1/2 turn clockwise as illustrated in the figure above, or tighten to 20 ft-lb.
- 5 - Place the remaining Teflon® washer around the other end of the check expansion valve. Lightly lubricate connector threads and expose surface of the Teflon® ring with refrigerant oil.
- 6 - Attach the liquid line assembly to the check expansion valve. Finger tighten and use an appropriately sized wrench to turn an additional 1/2 turn clockwise as illustrated in the figure above or tighten to 20 ft-lb.

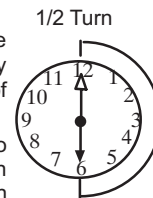

### SENSING BULB INSTALLATION

- 1 - Attach the vapor line sensing bulb in the proper orientation as illustrated to the right using the clamp and screws provided.

**NOTE** - Though it is preferred to have the sensing bulb installed on a horizontal run of the vapor line, installation on a vertical run of piping is acceptable if necessary.

**NOTE** - Confirm proper thermal contact between vapor line and check/expansion bulb before insulating the sensing bulb once installed.

- 2 - Connect the equalizer line from the check expansion valve to the equalizer vapor port on the vapor line. Finger tighten the flare nut plus 1/8 turn (7 ft-lbs) as illustrated below.

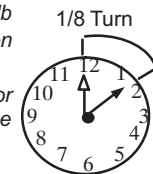

### EQUALIZER LINE INSTALLATION

- 1 - Remove and discard either the flare seal cap or flare nut with copper flare seal bonnet from the equalizer line port on the vapor line as illustrated in the figure below.
- 2 - Remove the field-provided fitting that temporarily reconnected the liquid line to the indoor unit's distributor assembly.

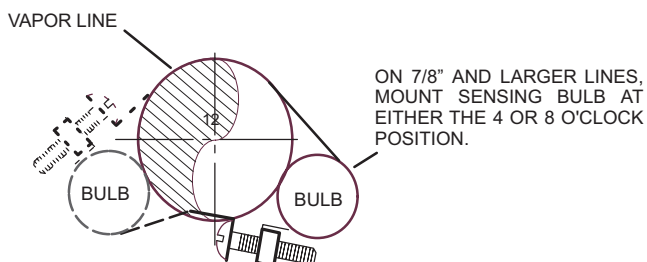
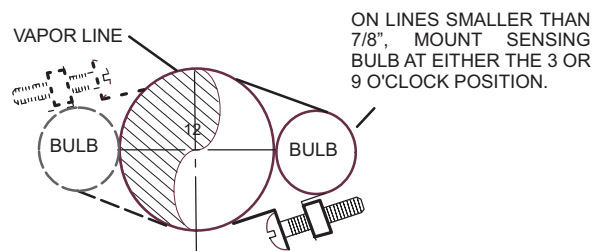
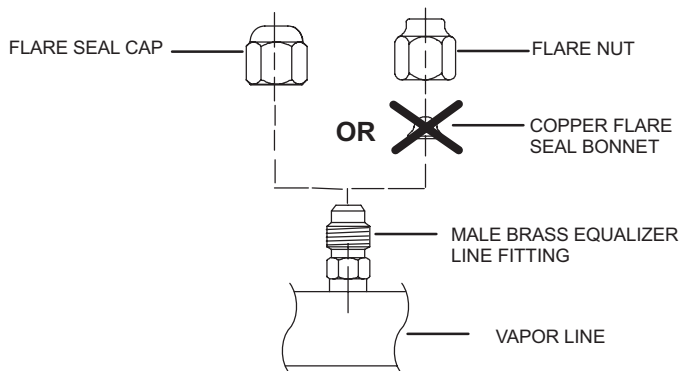

**NOTE** - NEVER MOUNT THE SENSING BULB ON BOTTOM OF LINE.

FIGURE 7

## STEP 3 – LEAK TEST AND EVACUATION

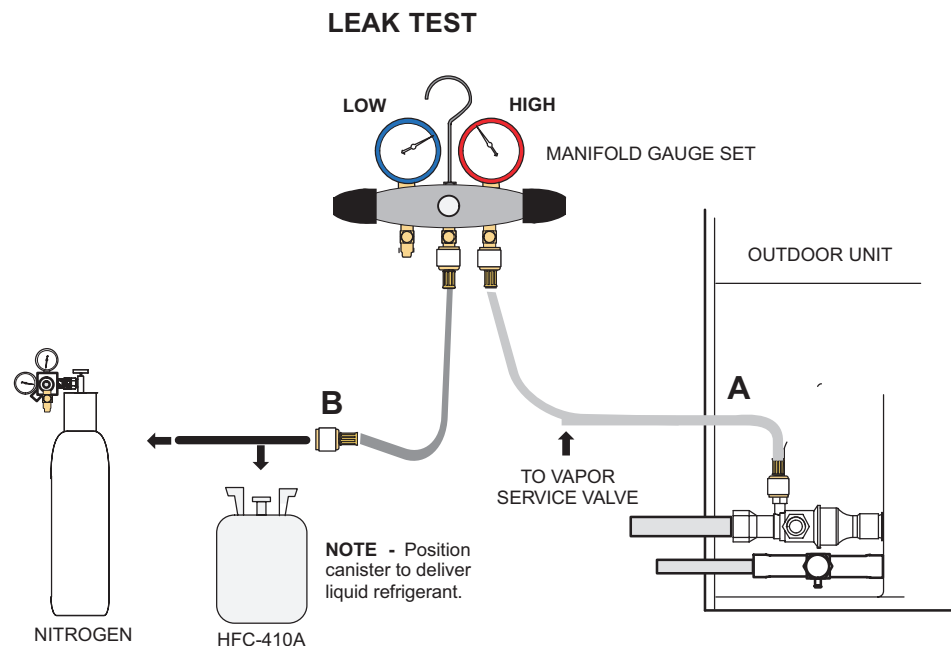

### 1 CONNECT GAUGE SET

**A** - Connect the high pressure hose of an HFC-410A manifold gauge set to the vapor valve service port.

**NOTE** - Normally, the high pressure hose is connected to the liquid line port. However, connecting it to the vapor port better protects the manifold gauge set from high pressure damage.

**B** - With both manifold valves closed, connect the cylinder of HFC-410A refrigerant to the center port of the manifold gauge set.

**NOTE** - Later in the procedure, the HFC-410A container will be replaced by the nitrogen container.

### 2 TEST FOR LEAKS

After the line set has been connected to the indoor and outdoor units, check the line set connections and indoor unit for leaks. Use the following procedure to test for leaks:

**A** - With both manifold valves closed, connect the cylinder of HFC-410A refrigerant to the center port of the manifold gauge set. Open the valve on the HFC-410A cylinder (vapor only).

**B** - Open the high pressure side of the manifold to allow HFC-410A into the line set and indoor unit. Weigh in a trace amount of HFC-410A. [A trace amount is a maximum of two ounces (57 g) refrigerant or three pounds (31 kPa) pressure.] Close the valve on the HFC-410A cylinder and the valve on the high pressure side of the manifold gauge set. Disconnect the HFC-410A cylinder.

**C** - Connect a cylinder of nitrogen with a pressure regulating valve to the center port of the manifold gauge set.

**D** - Adjust nitrogen pressure to 150 psig (1034 kPa). Open the valve on the high side of the manifold gauge set in order to pressurize the line set and the indoor unit.

**E** - After a few minutes, open one of the service valve ports and verify that the refrigerant added to the system earlier is measurable with a leak detector.

**F** - After leak testing, disconnect gauges from service ports.

**FIGURE 8**

### 3 CONNECT GAUGE SET

**NOTE** - Remove cores from service valves (if not already done).

- A - Connect low side of manifold gauge set with 1/4 SAE in-line tee to vapor line service valve
- B - Connect high side of manifold gauge set to liquid line service valve
- C - Connect available micron gauge connector on the 1/4 SAE in-line tee.
- D - Connect the vacuum pump (with vacuum gauge) to the center port of the manifold gauge set. The center port line will be used later for both the HFC-410A and nitrogen containers.

**NOTE** - Position canister to deliver liquid refrigerant.

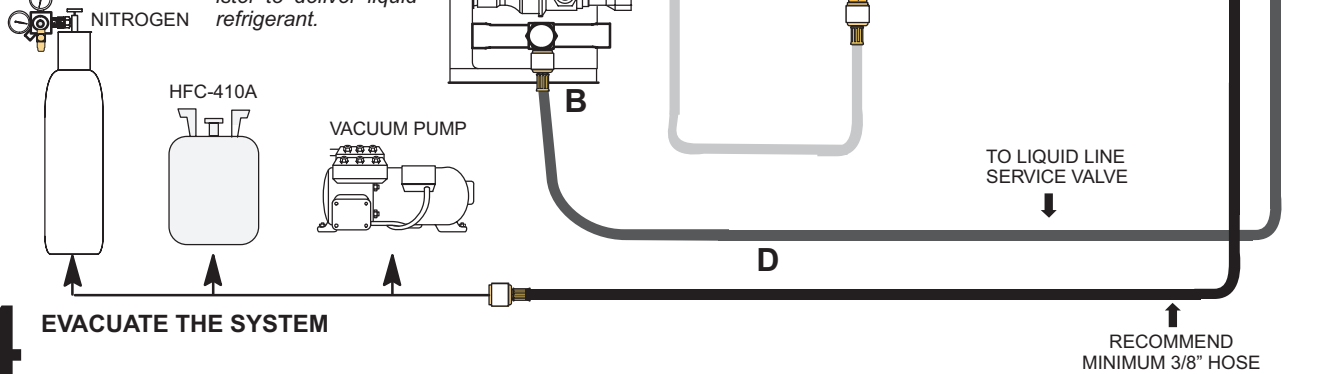

### 4 EVACUATE THE SYSTEM

- A - Open both manifold valves and start the vacuum pump.
- B - Evacuate the line set and indoor unit to an **absolute pressure** of 23,000 microns (29.01 inches of mercury).
  - NOTE** - During the early stages of evacuation, it is desirable to close the manifold gauge valve at least once. A rapid rise in pressure indicates a relatively large leak. If this occurs, **repeat the leak testing procedure**.
  - NOTE** - The term **absolute pressure** means the total actual pressure above absolute zero within a given volume or system. Absolute pressure in a vacuum is equal to atmospheric pressure minus vacuum pressure.
- C - When the absolute pressure reaches 23,000 microns (29.01 inches of mercury), perform the following:
  - Close manifold gauge valves.
  - Close valve on vacuum pump.
  - Turn off vacuum pump.
  - Disconnect manifold gauge center port hose from vacuum pump.
  - Attach manifold center port hose to a nitrogen cylinder with pressure regulator set to 150 psig (1034 kPa) and purge the hose.
  - Open manifold gauge valves to break the vacuum in the line set and indoor unit.
  - Close manifold gauge valves.
- D - Shut off the nitrogen cylinder and remove the manifold gauge hose from the cylinder. Open the manifold gauge valves to release the nitrogen from the line set and indoor unit.
- E - Reconnect the manifold gauge to the vacuum pump, turn the pump on, and continue to evacuate the line set and indoor unit until the absolute pressure does not rise above 500 microns (29.9 inches of mercury) within a 20-minute period after shutting off the vacuum pump and closing the manifold gauge valves.
- F - When the absolute pressure requirement above has been met, disconnect the manifold hose from the vacuum pump and connect it to a cylinder of HFC-410A positioned to deliver liquid refrigerant. Open the manifold gauge valve 1 to 2 psig in order to release the vacuum in the line set and indoor unit.
- G - Perform the following:
  - Close manifold gauge valves.
  - Shut off HFC-410A cylinder.
  - Reinstall service valve cores by removing manifold hose from service valve. Quickly install cores with core tool while maintaining a positive system pressure.
  - Replace stem caps and finger tighten them, then tighten an additional one-sixth (1/6) of a turn as illustrated.

**WARNING !**

**Possible equipment damage.**

**Avoid deep vacuum operation. Do not use compressors to evacuate a system. Extremely low vacuum can cause internal arcing and compressor failure. Damage caused by deep vacuum operation will void warranty.**

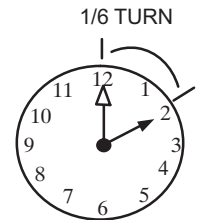

FIGURE 9

## STEP 4 – ELECTRICAL – Circuit Sizing and Wire Routing

In the U.S.A., wiring must conform with current local codes and the current National Electric Code (NEC). In Canada, wiring must conform with current local codes and the current Canadian Electrical Code (CEC).

Refer to the furnace or air handler installation instructions for additional wiring application diagrams and refer to unit nameplate for minimum circuit ampacity and maximum overcurrent protection size.

### 24VAC TRANSFORMER

Use the transformer provided with the furnace or air handler for low-voltage control power (24VAC - 40 VA minimum)

## ⚠ WARNING



Electric Shock Hazard. Can cause injury or death. Unit must be properly grounded in accordance with national and local codes.

Line voltage is present at all components when unit is not in operation on units with single-pole contactors. Disconnect all remote electric power supplies before opening access panel. Unit may have multiple power supplies.

## ⚠ WARNING

Fire Hazard. Use of aluminum wire with this product may result in a fire, causing property damage, severe injury or death. Use copper wire only with this product.

## ⚠ WARNING

Failure to use properly sized wiring and circuit breaker may result in property damage. Size wiring and circuit breaker(s) per Product Specifications bulletin (EHB) and unit rating plate.

## ⚠ WARNING

ELECTROSTATIC DISCHARGE (ESD)  
Precautions and Procedures

Electrostatic discharge can affect electronic components. Take care during unit installation and service to protect the unit's electronic controls. Precautions will help to avoid control exposure to electrostatic discharge by putting the unit, the control and the technician at the same electrostatic potential. Touch hand and all tools on an unpainted unit surface before performing any service procedure to neutralize electrostatic charge.

### SIZE CIRCUIT AND INSTALL SERVICE DISCONNECT SWITCH

Refer to the unit nameplate for minimum circuit ampacity, and maximum fuse or circuit breaker (HACR per NEC). Install power wiring and properly sized disconnect switch.

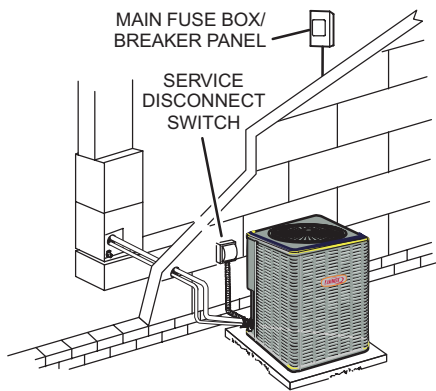

**NOTE** - Units are approved for use only with copper conductors. Ground unit at disconnect switch or connect to an earth ground.

### INSTALL THERMOSTAT

Install room thermostat (ordered separately) on an inside wall approximately in the center of the conditioned area and 5 feet (1.5m) from the floor. It should not be installed on an outside wall or where it can be affected by sunlight or drafts.

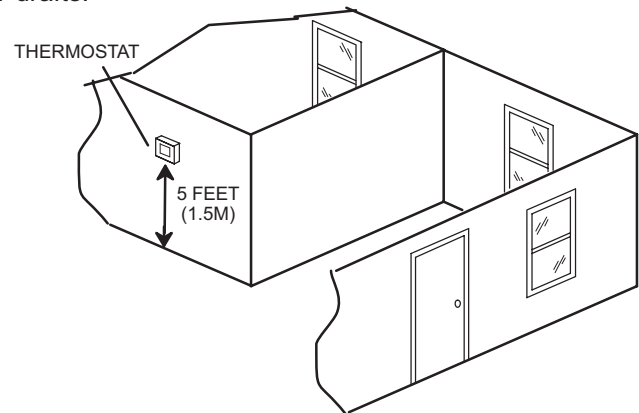

**NOTE** - 24VAC, Class II circuit connections are made in the control panel.

FIGURE 10

## STEP 4 – ELECTRICAL – (Continued) – High Voltage and Field Control Wiring

The following illustration provides an example of control wiring connections when using a standard thermostat.

### ROUTING HIGH VOLTAGE, GROUND AND CONTROL WIRING

#### HIGH VOLTAGE / GROUND WIRES

Any excess high voltage field wiring should be trimmed and secured away from any low voltage field wiring. To facilitate a conduit, a cutout is located in the bottom of the control panel. Connect conduit to the control panel using a proper conduit fitting.

#### TYPICAL CONTROL WIRING

Install low voltage wiring from outdoor to indoor unit and from thermostat to indoor unit as illustrated.

**A -** Run 24VAC control wires through hole with grommet.

**NOTE -** Do not bundle any excess 24VAC control wires inside control panel.

**B -** Make 24VAC thermostat wire connections to CMC1.

**NOTE -** For proper voltages, select thermostat wire (control wires) gauge per table below.

WIRE RUN LENGTH	AWG#	INSULATION TYPE
LESS THAN 100' (30 METERS)	18	TEMPERATURE RATING
MORE THAN 100' (30 METERS)	16	35°C MINIMUM.

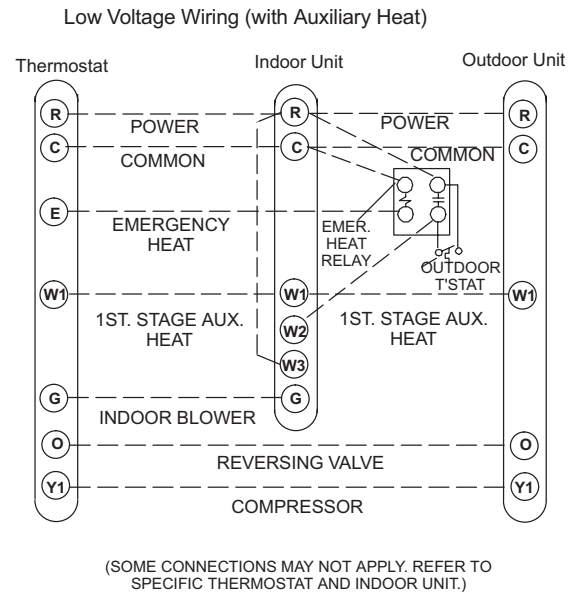
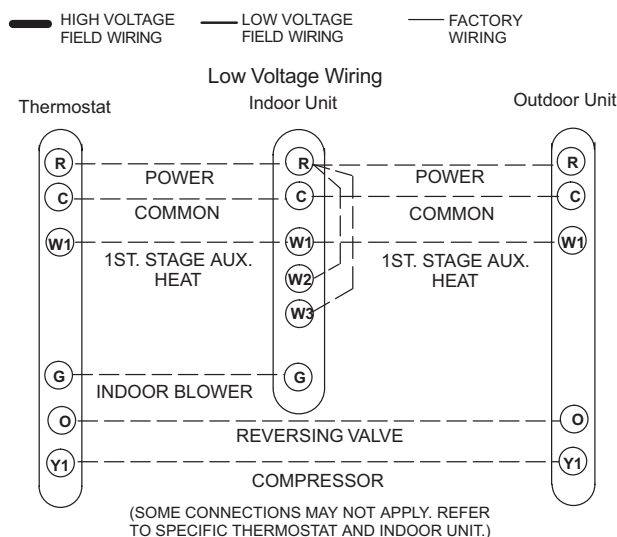

**NOTE -** Wire tie provides low voltage wire strain relief and maintains separation of field-installed low and high voltage circuits.

FIGURE 11

## STEP 5 – UNIT START-UP

### ⚠ IMPORTANT

If unit is equipped with a crankcase heater, it should be energized 24 hours before unit start-up to prevent compressor damage as a result of slugging.

- 1 - Rotate fan to check for binding.
- 2 - Inspect all factory- and field-installed wiring for loose connections.
- 3 - After evacuation is complete, open the liquid line and vapor line service valve stems to release the refrigerant charge (contained in outdoor unit) into the system.
- 4 - Replace the stem caps and tighten to the value listed in table 2.
- 5 - Check voltage supply at the disconnect switch. The voltage must be within the range listed on the unit's nameplate. If not, do not start the equipment until you have consulted with the power company and

the voltage condition has been corrected.

- 6 - Connect manifold gauge set for testing and charging.
- 7 - Set the thermostat for a cooling demand. Turn on power to the indoor indoor unit and close the outdoor unit disconnect switch to start the unit.
- 8 - Recheck voltage while the unit is running. Power must be within range shown on the unit nameplate.
- 9 - Check system for sufficient refrigerant using the procedures outlined under *Checking Refrigerant Charge*.

#### OPERATING MANIFOLD GAUGE SET AND SERVICE VALVES

The liquid and vapor line service valves are used for removing refrigerant, flushing, leak testing, evacuating, checking charge and charging.

Each valve is equipped with a service port which has a factory-installed valve stem. Figures 12 and 13 provide information on how to access and operate both angle- and ball-type service valves.

## Torque Requirements

When servicing or repairing heating, ventilating and air conditioning components, ensure the fasteners are appropriately tightened. Table 2 lists torque values for fasteners.

**TABLE 2  
TORQUE REQUIREMENTS**

Parts	Recommended Torque	
Service valve cap	8 ft.-lb.	11 NM
Sheet-metal screws	16 in.-lb.	2 NM
Machine screws #10	28 in.-lb.	3 NM
Compressor bolts	90 in.-lb.	10 NM
Gauge port seal cap	8 ft.-lb.	11 NM

## **▲ IMPORTANT**

To prevent stripping of the various caps used, the appropriately sized wrench should be used and fitted snugly over the cap before tightening.

## Using Manifold Gauge Set

When checking the system charge, only use a manifold gauge set that features low loss anti-blow back fittings.

Manifold gauge set used with HFC-410A refrigerant systems must be capable of handling the higher system operating pressures. The gauges should be rated for use with pressures of 0 - 800 psig on the high side and a low side of 30" vacuum to 250 psig with dampened speed to 500 psi. Gauge hoses must be rated for use at up to 800 psig of pressure with a 4000 psig burst rating.

## OPERATING BALL-TYPE SERVICE VALVE

- 1 - Remove stem cap with an appropriately sized wrench.
- 2 - Use an appropriately sized wrench to open. To open valve, rotate stem counterclockwise 90°. To close, rotate stem clockwise 90°.

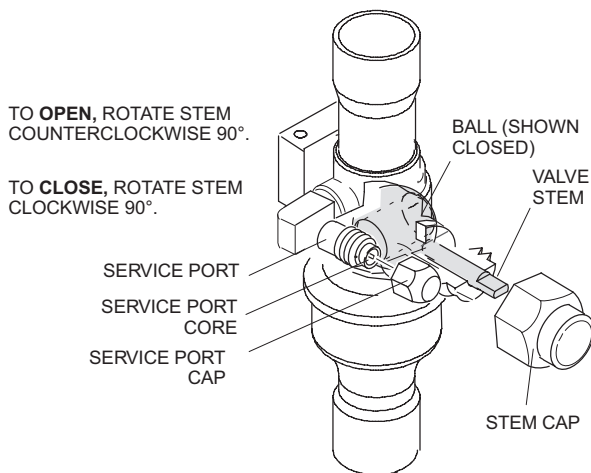

**FIGURE 12**

## OPERATING ANGLE-TYPE SERVICE VALVE

- 1 - Remove stem cap with an appropriately sized wrench.
- 2 - Use a service wrench with a hex-head extension (3/16" for liquid line valve sizes and 5/16" for vapor line valve sizes) to back the stem out counterclockwise as far as it will go.

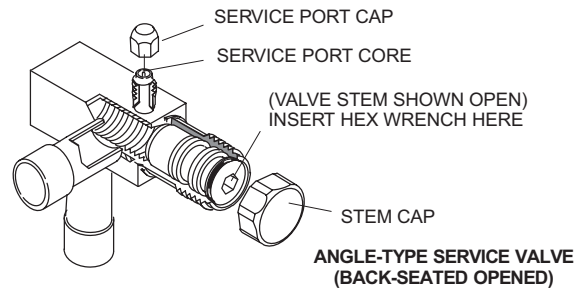

When service valve is **OPEN**, the service port is open to line set, indoor and outdoor unit.

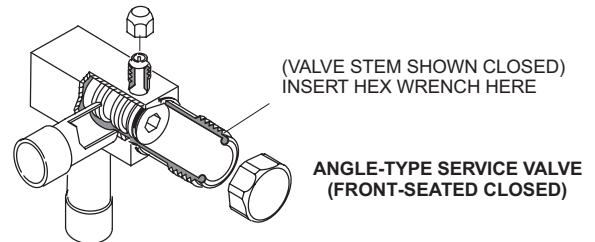

When service valve is **CLOSED**, the service port is open to the line set and indoor unit.

**NOTE** - A label with specific torque requirements may be affixed to the stem cap. If the label is present, use the specified torque.

**FIGURE 13**

## ACCESS SERVICE PORT

A service port cap protects the service port core from contamination and serves as the primary leak seal.

- 1 - Remove service port cap with an appropriately sized wrench.
- 2 - Connect gauge set to service port.
- 3 - When testing is completed, replace service port cap and tighten as follows:
  - With torque wrench, finger tighten and torque cap per table 2.
  - Without torque wrench, finger tighten and use an appropriately sized wrench to turn an additional 1/6 turn clockwise.

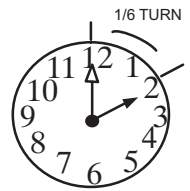

## Reinstall Stem Cap

Stem cap protects the valve stem from damage and serves as the primary seal. Replace the stem cap and tighten as follows:

- With torque wrench, finger tighten and then torque cap per table 2.
- Without torque wrench, finger tighten and use an appropriately sized wrench to turn an additional 1/12 turn clockwise.

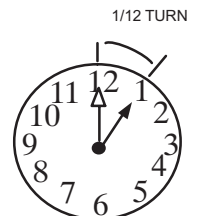

**FIGURE 14**

## Checking Refrigerant Charge

The ML17XP1 unit is factory-charged with enough HFC-410A refrigerant to accommodate a 15-foot length of refrigerant piping. **Charge should be checked and adjusted using the tables provided on the charging procedure sticker on the unit access panel.** Detailed information is given in the ML17XP1 Installation and Service Procedures manual, which is available on LennoxPros.com.

## Defrost System

This section addresses:

- Emergency Heat
- Defrost System Overview
- Defrost Control Connections, Jumper Settings and Features
- Operational Mode Overview (Calibration, Normal and Defrost)
- Defrost Cycle Actuation

### EMERGENCY HEAT (AMBER LIGHT)

An emergency heat function is designed into some room thermostats. This feature is applicable when isolation of the outdoor unit is required, or when auxiliary electric heat is staged by outdoor thermostats. When the room thermostat is placed in the emergency heat position, the outdoor unit control circuit is isolated from power and field-provided relays bypass the outdoor thermostats. An amber indicating light simultaneously comes on to remind the homeowner that he is operating in the emergency heat mode.

Emergency heat is usually used during an outdoor unit shutdown, but it should also be used following a power outage if power has been off for over an hour and the outdoor temperature is below 50°F (10°C). System should be left in the emergency heat mode at least six hours to allow the crankcase heater sufficient time to prevent compressor slugging.

### DEFROST SYSTEM OVERVIEW

The control monitors ambient temperature, outdoor coil temperature, and total run time to determine when a defrost cycle is required. The coil temperature probe is designed with a spring clip to allow mounting to the outside coil tubing. The location of the coil sensor is important for proper defrost operation.

**NOTE** – The demand defrost control accurately measures the performance of the system as frost accumulates on the outdoor coil. This typically will translate into longer running time between defrost cycles as more frost accumulates on the outdoor coil before the demand defrost control initiates defrost cycles.

## DEFROST CONTROL CONNECTIONS, JUMPER SETTINGS AND FEATURES

### Defrost Temperature Termination Jumper Settings (P1)

The demand defrost control selections are: 50, 70, 90 and 100°F (10, 21, 32 and 38°C). The shunt termination pin is factory set at 50°F (10°C). If temperature shunt is not installed, default termination temperature is 90°F (32°C).

#### Test Pins (P1) Function

Placing the jumper on the field test pins (P1) allows the technician to:

- Clear short cycle lockout
- Clear five-strike fault lockout
- Cycle the unit in and out of defrost mode
- Place the unit in defrost mode to clear the coil

#### Compressor Delay Mode (P5)

The demand defrost control has a field-selectable function to reduce occasional sounds that may occur while the unit is cycling in and out of the defrost mode. When a jumper is installed on the **DELAY** pins, the compressor will be cycled off for 30 seconds going in and out of the defrost mode. Units are shipped with jumper installed on **DELAY** pins.

**NOTE** – The 30 second off cycle is **NOT** functional when jumpering the **TEST** pins.

#### HIGH PRESSURE SWITCH (S4)

This unit is equipped with a high pressure switch which is located on the liquid line. The SPST, normally closed pressure switch opens when liquid line pressure rises above the factory setting of 590 + 15 psig and automatically resets at 418 + 15 psig.

#### LOW PRESSURE SWITCH (S87)

This unit is equipped with a low pressure switch which is located on the suction line. The SPST, normally open pressure switch opens when suction line pressure falls below the factory setting of 25 ± 5 psig and closes when pressure rises at 40 ± 5 psig.

## DEMAND DEFROST CONTROL (A108) DIAGNOSTIC LEDs

The state (Off, On, Flashing) of two LEDs on the demand defrost control (DS1 [Red] and DS2 [Green]) indicate diagnostics conditions that are described in table 3.

DS1 and DS2 System Status, Fault and Lockout Codes					
DS2 Green	DS1 Red	Type	Condition/Code	Possible Cause(s)	Solution
OFF	OFF	Status	Power problem	No power (24V) to demand defrost control terminals R and C or demand defrost control failure.	1. Check control transformer power (24V). 2. If power is available to demand defrost control and LED(s) do not light, replace demand defrost control.
Simultaneous SLOW Flash		Status	Normal operation	Unit operating normally or in standby mode.	None required.
Alternating SLOW Flash		Status	5-minute anti-short cycle delay	Initial power up, safety trip, end of room thermostat demand.	None required (jumper <b>TEST</b> pins to override)
Simultaneous FAST Flash		Fault	Ambient Sensor Problem	Sensor being detected open or shorted or out of temperature range. Demand defrost control will revert to time/temperature defrost operation. (System will still heat or cool).	
Alternating FAST Flash		Fault	Coil Sensor Problem	Sensor being detected open or shorted or out of temperature range. Demand defrost control will not perform demand or time/temperature defrost operation. (System will still heat or cool.)	
ON	ON	Fault	Demand Defrost Control Failure	Indicates that demand defrost control has internal component failure. Cycle 24VAC power to demand defrost control. If code does not clear, replace demand defrost control.	
OFF	SLOW Flash	Fault	Low Pressure Fault	<ul style="list-style-type: none"> <li>Restricted air flow over indoor or outdoor coil.</li> <li>Improper refrigerant charge in system.</li> <li>Improper metering device installed or incorrect operation of metering device.</li> <li>Incorrect or improper sensor location or connection to system.</li> </ul>	<ul style="list-style-type: none"> <li>Remove any blockages or restrictions from coils and/or fans. Check indoor and outdoor fan motor for proper current draws.</li> <li>Check system charge using subcooling method.</li> <li>Check system operating pressures and compare to unit subcooling tables in this instruction or located on unit access panel.</li> <li>Make sure all pressure switches and sensors have secure connections to system to prevent refrigerant leaks or errors in pressure and temperature measurements.</li> </ul>
OFF	ON	Lockout	Low Pressure Lockout		
SLOW Flash	OFF	Fault	High Pressure Fault		
ON	OFF	Lockout	High Pressure Lockout		
(Each fault adds 1 strike to that code's counter; 5 strikes per code = LOCKOUT)					

### Homeowners Information

## CAUTION

Before attempting to perform any service or maintenance, turn the electrical power to unit OFF at disconnect switch.

In order to ensure peak performance, your system must be properly maintained. Clogged filters and blocked air-flow prevent your unit from operating at its most efficient level. The system should be inspected and serviced before each cooling and heating season by a licensed professional HVAC service technician (or equivalent).

### Heat Pump Operation

Your new Lennox heat pump has several characteristics that you should be aware of:

- Heat pumps satisfy heating demand by delivering large amounts of *warm* air into the living space. This is quite different from gas- or oil-fired furnaces or an electric furnace which deliver lower volumes of considerably *hotter* air to heat the space.
- Do not be alarmed if you notice frost on the outdoor coil in the winter months. Frost develops on the outdoor coil during the heating cycle when temperatures are below 45°F (7°C). An electronic control activates a defrost cycle

lasting 5 to 15 minutes at preset intervals to clear the outdoor coil of the frost.

- During the defrost cycle, you may notice steam rising from the outdoor unit. This is a normal occurrence. The thermostat may engage auxiliary heat during the defrost cycle to satisfy a heating demand; however, the unit will return to normal operation at the conclusion of the defrost cycle.

### Homeowner Maintenance

The following maintenance may be performed by the homeowner.

- Contact a licensed professional HVAC technician to schedule inspection and maintenance appointments for your equipment before each heating and cooling season.
- Check the indoor unit filter each month and replace the filter, if necessary.
- Have your Lennox dealer show you where your indoor unit filter is located. It will be either at the indoor unit (installed internal or external to the cabinet) or behind a return air grille in the wall or ceiling. Check the filter monthly and clean or replace it as needed. Disposable filters should be replaced with a filter of the same type and size.

- Check the indoor unit drain line for obstructions monthly. The indoor coil is equipped with a drain pan to collect condensate formed as your system removes humidity from the inside air. Have your dealer show you the location of the drain line and how to check for obstructions. (This would also apply to an auxiliary drain, if installed.)
- Check the area around the outdoor unit monthly and remove any obstructions that may restrict airflow to the outdoor unit. This would include grass clippings, leaves, or papers that may have settled around the unit.
- Trim shrubbery away from the unit and periodically check for debris which collects around the unit.
- During the winter months, keep the snow level below the louvered panels.

**NOTE** - The filter and all access panels must be in place any time the unit is in operation. If you are unsure about the filter required for your system, call your Lennox dealer for assistance.

## **IMPORTANT**

**Sprinklers and soaker hoses should not be installed where they could cause prolonged exposure to the outdoor unit by treated water. Prolonged exposure of the unit to treated water (i.e., sprinkler systems, soakers, waste water, etc.) will corrode the surface of the steel and aluminum parts, diminish performance and affect longevity of the unit.**

### **Thermostat Operation**

See the thermostat homeowner manual for instructions on how to operate your thermostat.

### **Pre-Service Check**

If your system fails to operate, check the following before calling for service:

- Verify room thermostat settings are correct.
- Verify that all electrical disconnect switches are ON.
- Check for any blown fuses or tripped circuit breakers.
- Verify unit access panels are in place.
- Verify air filter is clean.

If service is needed, locate and write down the unit model number and have it handy before calling.

### **Extended Power Outage**

The heat pump is equipped with a compressor crankcase heater which protects the compressor during cold weather operation.

If power to your unit has been interrupted for several hours or more, set the room thermostat selector to the EMERGENCY HEAT setting to obtain temporary heat without the risk of serious damage to the heat pump.

In EMERGENCY HEAT mode, all heating demand is satisfied by auxiliary heat; heat pump operation is locked out. After a six-hour compressor crankcase warm-up period, the thermostat can be switched to the HEAT setting and normal heat pump operation may resume.

## **Professional Maintenance**

### **NOTICE !**

**Failure to follow instructions will cause damage to the unit.**

**This unit is equipped with an aluminum coil. Aluminum coils may be damaged by exposure to solutions with a pH below 5 or above 9. The aluminum coil should be cleaned using potable water at a moderate pressure (less than 50psi). If the coil cannot be cleaned using water alone, Lennox recommends use of a coil cleaner with a pH in the range of 5 to 9. The coil must be rinsed thoroughly after cleaning.**

**In coastal areas, the coil should be cleaned with potable water several times per year to avoid corrosive buildup (salt).**

Your heating and air conditioning system should be inspected and maintained twice each year (before the start of the cooling and heating seasons) by a licensed professional HVAC technician. You can expect the technician to check the following items. **These checks may only be conducted by a licensed professional HVAC technician.**

### **Outdoor Unit**

- 1 - Inspect component wiring for loose, worn or damaged connections. Also check for any rubbing or pinching of wires. Confirm proper voltage plus amperage of outdoor unit.
- 2 - Check the cleanliness of outdoor fan and blade condition (cracks) and clean or replace them, if necessary.
- 3 - Inspect base pan drains for debris and clean as necessary.
- 4 - Inspect the condition of refrigerant piping and confirm that pipes are not rubbing copper-to-copper. Also, check the condition of the insulation on the refrigerant lines. Repair, correct, or replace as necessary.
- 5 - Test capacitor. Replace as necessary.
- 6 - Inspect contactor contacts for pitting or burn marks. Replace as necessary.
- 7 - Check outdoor fan motor for worn bearings/bushings. Replace as necessary.
- 8 - Inspect and clean outdoor coils, if necessary and note any damage to coils or signs of leakage.

### **Indoor Unit (Air Handler or Furnace)**

- 1 - Inspect component wiring for loose, worn or damaged connections. Confirm proper voltage plus amperage of indoor unit.
- 2 - Inspect and clean or replace air filters in indoor unit.
- 3 - Check the cleanliness of indoor blower and clean blower, if necessary.

- 4 - Inspect the indoor coil drain pans and condensate drains for rust, debris, obstructions, leaks or cracks. Pour water in pans to confirm proper drainage from the pan through to the outlet of the pipe. Clean or replace as necessary.
- 5 - Inspect and clean indoor coil, if necessary.
- 6 - Inspect the condition of the refrigerant lines and confirm that pipes are not rubbing copper-to-copper. Also, ensure that refrigerant pipes are not being affected by indoor air contamination. Check condition of insulation on the refrigerant lines. Repair, correct, or replace as necessary.
- 7 - Inspect the duct system for leaks or other problems. Repair or replace as necessary.
- 8 - Check for bearing/bushing wear on indoor blower motor. Replace as necessary.

- 9 - If your heat pump is matched with a gas- or oil-fired furnace for auxiliary heating, indoor unit service will also include inspection and cleaning of the burners, and a full inspection of the gas valve, heat exchanger and flue (exhaust) system.

**General System Test with System Operating**

- 1 - Your technician should perform a general system test. He will turn on the air conditioner to check operating functions such as the startup and shutoff operation. He will also check for unusual noises or odors, and measure indoor/outdoor temperatures and system pressures as needed. He will check the refrigerant charge per the charging sticker information on the outdoor unit.
- 2 - Verify that system total static pressure and airflow settings are within specific operating parameters.
- 3 - Verify correct temperature drop across indoor coil.

<b>ML17XP1 Start-Up and Performance Checklist</b>	
Customer _____	Address _____
Indoor Unit Model _____	Serial _____
Outdoor Unit Model _____	Serial _____
Notes: _____	
<b>START UP CHECKS</b>	
Refrigerant Type: _____	
Rated Load Amps: _____	Actual Amps ___ Rated Volts _____ Actual Volts _____
Condenser Fan Full Load Amps _____	Actual Amps: ___
<b>COOLING MODE</b>	
Suction Pressure: _____	Liquid Pressure: _____
Supply Air <b>Temperature:</b> _____ Ambient <b>Temperature:</b> _____ Return Air: <b>Temperature:</b> _____	
System Refrigerant Charge (Refer to manufacturer's information on unit or installation instructions for required subcooling and approach temperatures.)	
Subcooling:	A — B = SUBCOOLING Saturated Condensing Temperature (A) <i>minus</i> Liquid Line Temperature (B)
Approach:	A — B = APPROACH Liquid Line Temperature (A) <i>minus</i> Outdoor Air Temperature (B)
Indoor Coil Temperature Drop (18 to 22°F)	A — B = COIL TEMP DROP Return Air Temperature (A) <i>minus</i> Supply Air Temperature (B)