



10641 Highway 36
Covington, GA
30014

www.sunbeltbuilders.com

t 770.786.3031
f 770.786.3046

Newton County – R.L. Cousins Center

Manning Brothers
210 Sandy Creek Drive
Athens, GA 30607
ph: 706-549-7088
Donna Smallwood
donna@manningbrothers.com

11-4400 Equipment O&M



HOSHIZAKI

Instruction Manual

Modular Crescent Cuber

Models

KM-350MAJ, MWJ

KM-520MAJ, MWJ, MRJ

KM-660MAJ, MWJ, MRJ



hoshizakiamerica.com

Issued: 7-23-2018
Revised: 10-25-2021

⚠ WARNING

Only qualified service technicians should install and service the appliance. To obtain the name and phone number of your local Hoshizaki Certified Service Representative, visit www.hoshizaki.com. No installation or service should be undertaken until the technician has thoroughly read this Instruction Manual. Likewise, the owner/manager should not proceed to operate the appliance until the installer has instructed them on its proper operation. Failure to install, operate, and maintain the appliance in accordance with this manual will adversely affect safety, performance, component life, and warranty coverage and may result in costly water damage. Proper installation is the responsibility of the installer. Product failure or property damage due to improper installation is not covered under warranty.

Hoshizaki provides this manual primarily to assist qualified service technicians in the installation, maintenance, and service of the appliance.

Should the reader have any questions or concerns which have not been satisfactorily addressed, please call, send an e-mail message, or write to the Hoshizaki Technical Support Department for assistance.

Phone: 1-800-233-1940; (770) 487-2331

Fax: 1-800-843-1056; (770) 487-3360

E-mail: techsupport@hoshizaki.com

HOSHIZAKI AMERICA, INC.

618 Highway 74 South

Peachtree City, GA 30269

Attn: Hoshizaki Technical Support Department

NOTE: To expedite assistance, all correspondence/communication **MUST** include the following information:

- Model Number _____
- Serial Number _____
- Complete and detailed explanation of the problem.

IMPORTANT

This manual should be read carefully before the appliance is installed and operated. Read the warnings and guidelines contained in this manual carefully as they provide essential information for the continued safe use and maintenance of the appliance. Retain this manual for any further reference that may be necessary.

CONTENTS

Important Safety Information	4
I. Specifications.....	6
A. Electrical and Refrigerant Data	6
1. KM-350M_J.....	6
2. KM-520M_J	6
3. KM-660M_J	7
B. Dimensions/Connections	8
1. Air-Cooled Models (MAJ)	8
2. Water-Cooled Models (MWJ)	9
3. Remote Models (MRJ).....	10
4. Remote Condenser Unit URC-5F (use with KM-520MRJ or KM-660MRJ)	11
II. Installation and Operating Instructions	12
A. Location	12
B. Checks Before Installation.....	13
C. How to Remove Panels	13
D. Setup.....	14
E. Electrical Connection	15
F. Water Supply and Drain Connections	16
G. Remote Condenser Unit Installation	20
1. Location	20
2. Checks Before Installation	21
3. Setup	21
4. Line Set Size and Refrigerant Charge	21
5. Line Set Installation	22
6. Electrical Connection.....	26
7. Stacking Remote Condenser Unit	27
H. Final Checklist.....	28
1. Pre-Startup	28
2. Post-Startup.....	29
I. Startup.....	30
1. Bin Control Setting	30
2. Appliance Startup and Bin Control Check	33
III. Maintenance	35
A. Maintenance Schedule.....	35
B. Cleaning and Sanitizing Instructions	36
IV. Preparing the Appliance for Periods of Non-Use	38
V. Disposal	40

Important Safety Information

Throughout this manual, notices appear to bring your attention to situations which could result in death, serious injury, damage to the appliance, or damage to property.

⚠ WARNING Indicates a hazardous situation which could result in death or serious injury.

NOTICE Indicates a situation which could result in damage to the appliance or property.

IMPORTANT Indicates important information about the installation, use, and care of the appliance.

⚠ WARNING

The appliance should be destined only to the use for which it has been expressly conceived. Any other use should be considered improper and therefore dangerous. The manufacturer cannot be held responsible for injury or damage resulting from improper, incorrect, and unreasonable use. Failure to install, operate, and maintain the appliance in accordance with this manual will adversely affect safety, performance, component life, and warranty coverage and may result in costly water damage.

To reduce the risk of death, electric shock, serious injury, or fire, follow basic precautions including the following:

- Only qualified service technicians should install and service the appliance.
- The appliance must be installed in accordance with applicable national, state, and local codes and regulations.
- Electrical connection must be hard-wired and must meet national, state, and local electrical code requirements. Failure to meet these code requirements could result in death, electric shock, serious injury, fire, or damage.
- The appliance requires an independent power supply of proper capacity. See the nameplate for electrical specifications. Failure to use an independent power supply of proper capacity can result in a tripped breaker, blown fuse, damage to existing wiring, or component failure. This could lead to heat generation or fire.
- **THE ICEMAKER MUST BE GROUNDED.** Failure to properly ground the icemaker could result in death or serious injury.
- Move the control switch to the "OFF" position and turn off the power supply before servicing. Lockout/Tagout to prevent the power supply from being turned back on inadvertently.
- To reduce the risk of electric shock, do not touch the control switch or mode switch with damp hands.
- Do not make any alterations to the appliance. Alterations could result in electric shock, serious injury, fire, or damage.
- The appliance is not intended for use by persons (including children) with reduced physical, sensory, or mental capabilities, or lack of experience and knowledge, unless they have been given supervision or instruction concerning use of the appliance by a person responsible for their safety.

⚠ WARNING, continued

- Children should be properly supervised around the appliance.
- Do not climb, stand, or hang on the appliance or allow children or animals to do so. Serious injury could occur or the appliance could be damaged.
- Do not use combustible spray or place volatile or flammable substances near the appliance. They might catch fire.
- Keep the area around the appliance clean. Dirt, dust, or insects in the appliance could cause harm to individuals or damage to the appliance.

Additional Warning for Remote Models

- **THE REMOTE CONDENSER UNIT MUST BE GROUNDED.** The power supply and ground connection to the remote condenser unit are supplied from the icemaker. Failure to properly ground the remote condenser unit could result in death or serious injury.
- Wire routing (conduit) and disconnect (if required) must meet national, state, and local electrical code requirements. Failure to meet these code requirements could result in death, electric shock, serious injury, fire, or damage.

NOTICE

- Follow the water supply, drain connection, and maintenance instructions carefully to reduce the risk of costly water damage.
- In areas where water damage is a concern, install in a contained area with a floor drain.
- Install the appliance in a location that stays above freezing. Normal operating ambient temperature must be within 45°F to 100°F (7°C to 38°C).
- Do not leave the appliance on during extended periods of non-use, extended absences, or in sub-freezing temperatures. To properly prepare the appliance for these occasions, follow the instructions in "IV. Preparing the Appliance for Periods of Non-Use."
- Do not place objects on top of the appliance.
- The dispenser unit/ice storage bin is for ice use only. Do not store anything else in the dispenser unit/ice storage bin.

I. Specifications

A. Electrical and Refrigerant Data

The rating label and nameplate provide electrical and refrigerant data. The rating label can be seen by removing the front panel. The nameplate is located on the rear panel. For certification marks, see the nameplate.

We reserve the right to make changes in specifications and design without prior notice.

1. KM-350M_J

Single Phase		
Model Number	KM-350MAJ	KM-350MWJ
AC Supply Voltage	115/60/1	115/60/1
Compressor	115V 7.5RLA 50LRA	115V 6.8RLA 50LRA
Pump	120V 0.4FLA 10W	120V 0.4FLA 10W
Fan	115V 1.0FLA 1/15 HP	--- --- ---
Other	115V 0.15A	115V 0.15A
Maximum Fuse Size	15 AMPS	15 AMPS
Max. HACR Breaker (USA Only)	15 AMPS	15 AMPS
Max. Circuit Breaker (Canada Only)	15 AMPS	15 AMPS
Minimum Circuit Ampacity	15 AMPS	15 AMPS
Design Pressure	HI-467PSI LO-250PSI	HI-427PSI LO-250PSI
Refrigerant	404A 1 LB. 3.4 OZ.	404A 11.6 OZ.

2. KM-520M_J

Single Phase			
Model Number	KM-520MAJ	KM-520MWJ	KM-520MRJ
AC Supply Voltage	115/60/1	115/60/1	115/60/1
Compressor	115V 8.9RLA 54.5LRA	115V 7.8RLA 54.5LRA	115V 8.4RLA 54.5LRA
Pump	120V 0.5FLA 10W	120V 0.5FLA 10W	120V 0.5FLA 10W
Fan	120V 1.0FLA 1/15 HP	--- --- ---	120V 3A MAX
Other	115V 0.15A	115V 0.15A	115V 0.15A
Maximum Fuse Size	20 AMPS	20 AMPS	20 AMPS
Max. HACR Breaker (USA Only)	20 AMPS	20 AMPS	20 AMPS
Max. Circuit Breaker (Canada Only)	20 AMPS	20 AMPS	20 AMPS
Minimum Circuit Ampacity	20 AMPS	20 AMPS	20 AMPS
Design Pressure	HI - 467PSI LO - 250PSI	HI - 427PSI LO - 250PSI	HI - 467PSI LO - 250PSI
Refrigerant	404A 1 LB 10.8 OZ.	404A 12.7 OZ.	R404A Total Refrigerant Charge with Hoshizaki Remote Condenser Unit URC-5F: 4 LB. 2.7 OZ.

3. KM-660M_J

Single Phase			
Model Number	KM-660MAJ	KM-660WJ	KM-660MRJ
AC Supply Voltage	115/60/1	115/60/1	115/60/1
Compressor	115V 13.5RLA 77LRA	115V 11.7RLA 77LRA	115V 12.6RLA 77LRA
Pump	120V 0.5FLA 10W	120V 0.5FLA 10W	120V 0.5FLA 10W
Fan	120V 1.0FLA 1/15 HP	--- --- ---	120V 3A MAX
Other	115V 0.15A	115V 0.15A	115V 0.15A
Maximum Fuse Size	20 AMPS	20 AMPS	20 AMPS
Max. HACR Breaker (USA Only)	20 AMPS	20 AMPS	20 AMPS
Max. Circuit Breaker (Canada Only)	20 AMPS	20 AMPS	20 AMPS
Minimum Circuit Ampacity	20 AMPS	20 AMPS	20 AMPS
Design Pressure	HI - 467PSI LO - 250PSI	HI - 467PSI LO - 250PSI	HI - 467PSI LO - 250PSI
Refrigerant	404A 1 LB. 9.8 OZ.	404A 15.2 OZ.	R404A Total Refrigerant Charge with Hoshizaki Remote Condenser Unit URC-5F: R404A 4 LB. 2.7 OZ.

B. Dimensions/Connections

1. Air-Cooled Models (MAJ)

Units: mm [in.]

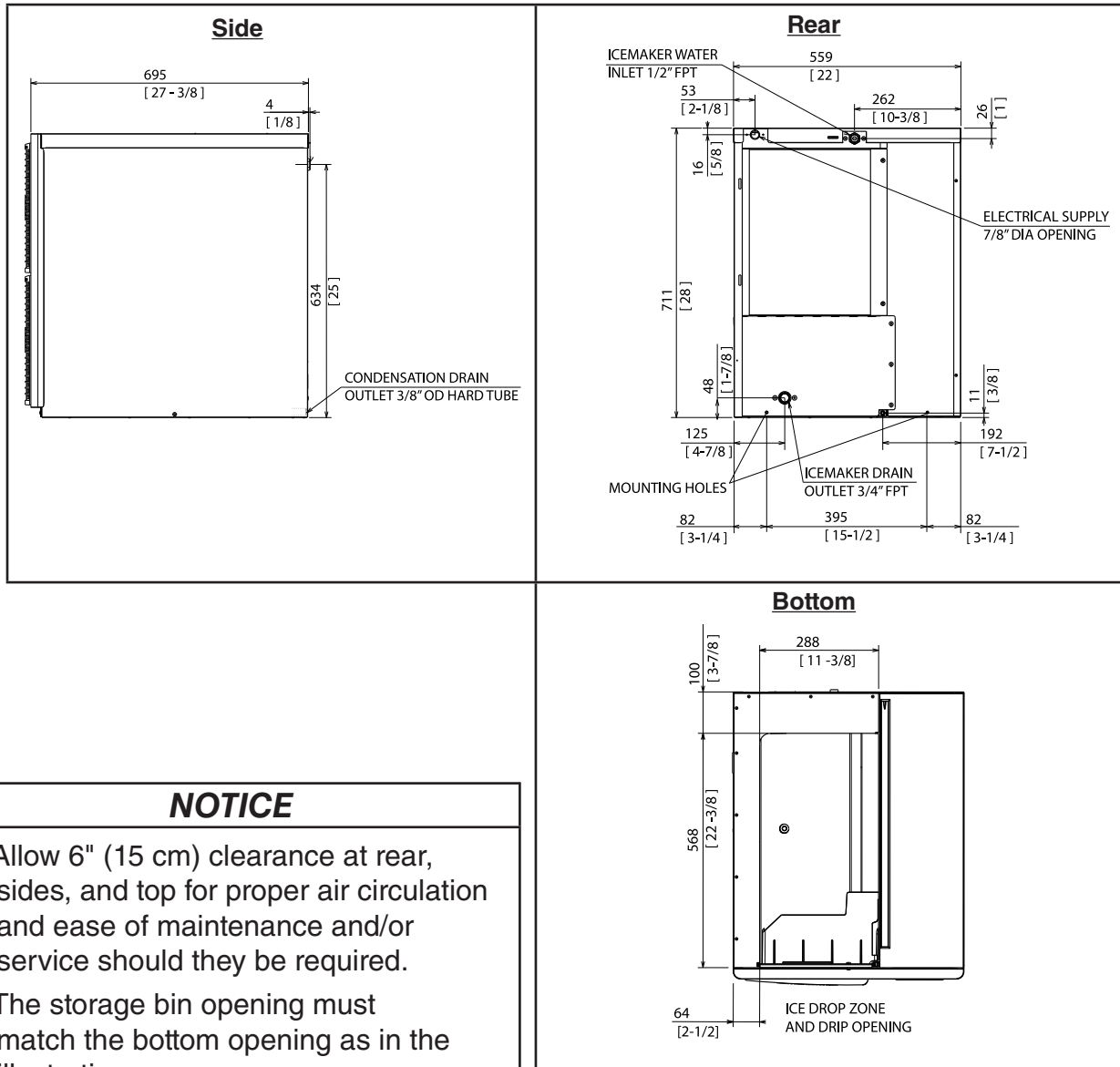

NOTICE

- Allow 6" (15 cm) clearance at rear, sides, and top for proper air circulation and ease of maintenance and/or service should they be required.
- The storage bin opening must match the bottom opening as in the illustration.

2. Water-Cooled Models (MWJ)

Units: mm [in.]

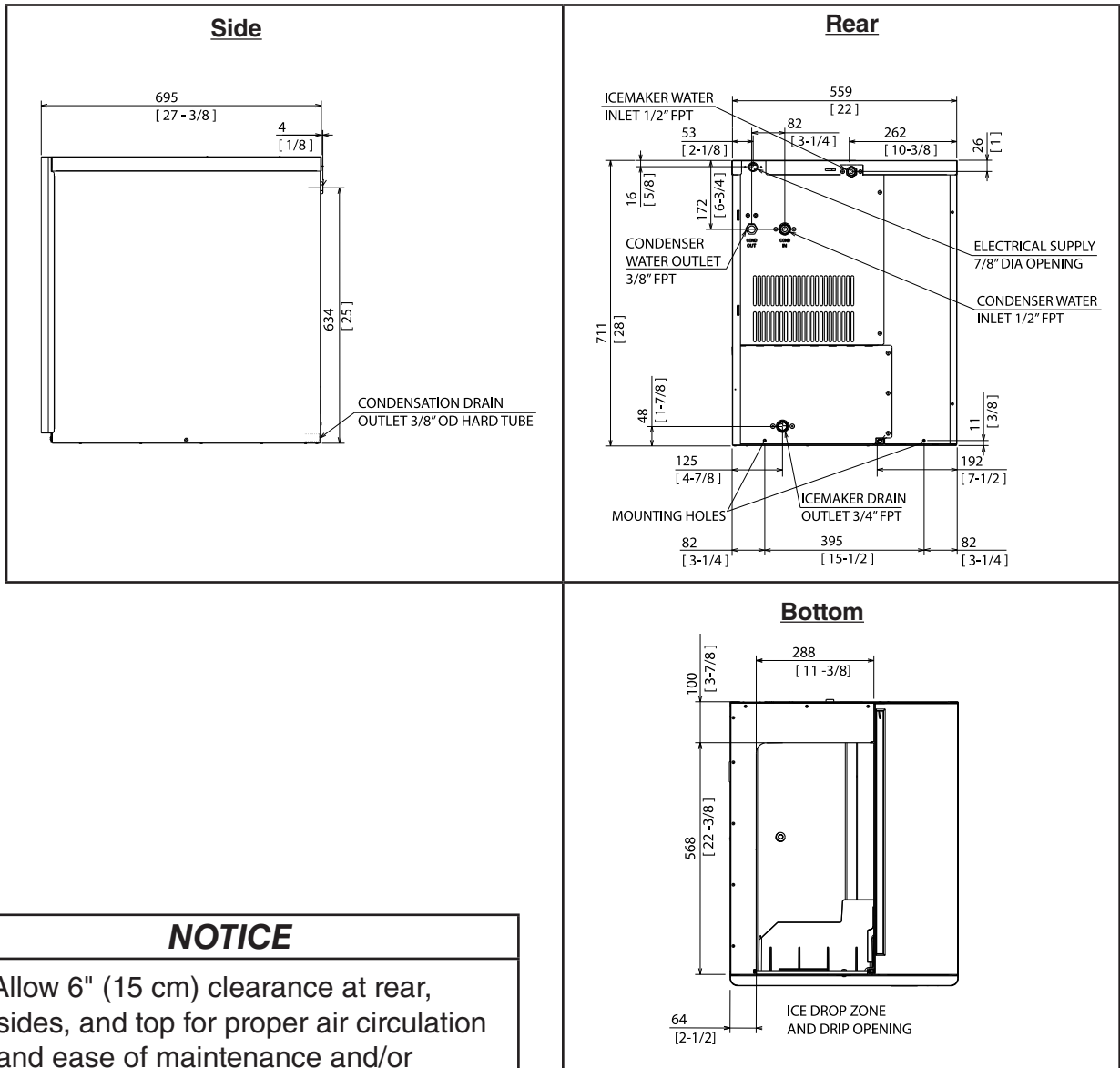

NOTICE

- Allow 6" (15 cm) clearance at rear, sides, and top for proper air circulation and ease of maintenance and/or service should they be required.
- The storage bin opening must match the bottom opening as in the illustration.

3. Remote Models (MRJ)

Units: mm [in.]

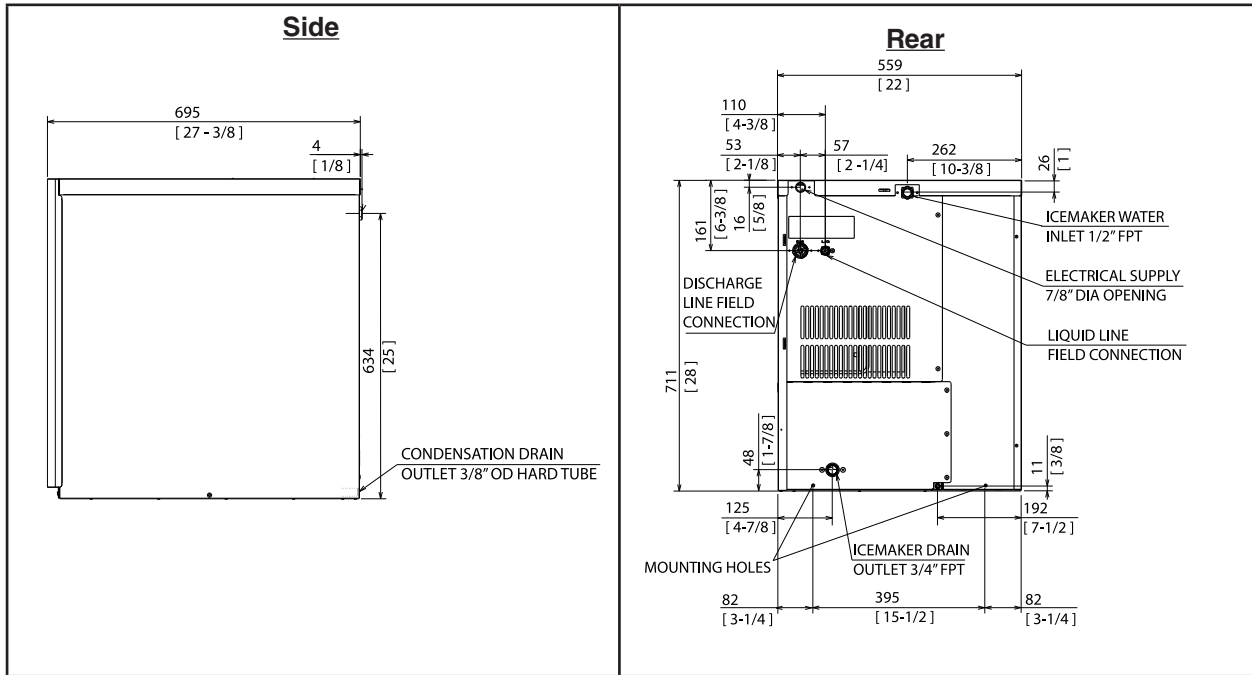

NOTICE

- Allow 6" (15 cm) clearance at rear, sides, and top for proper air circulation and ease of maintenance and/or service should they be required.
- The storage bin opening must match the bottom opening as in the illustration.

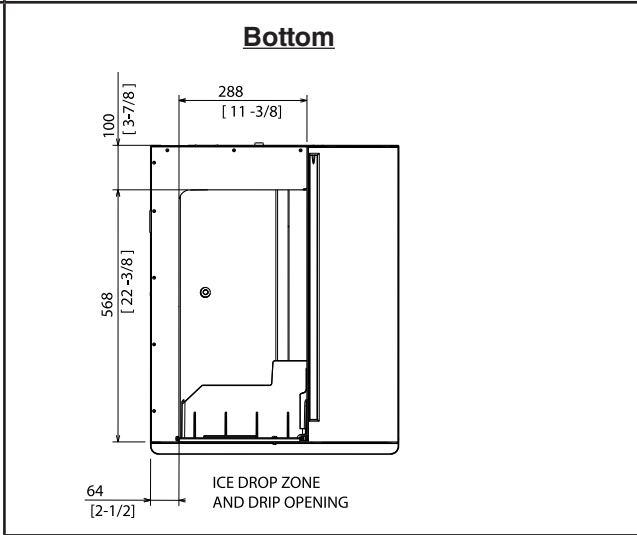

4. Remote Condenser Unit URC-5F (use with KM-520MRJ or KM-660MRJ)

Units: mm [in.]

NOTICE

Allow 24" (61 cm) clearance at front and rear for proper air circulation and ease of maintenance and/or service should they be required.

Icemaker Model	URC-5F Heat of Rejection AT 90°F (32°C) WT 70°F (21°C)
KM-520MRJ	6,200BTU/hr
KM-660MRJ	8,100BTU/hr

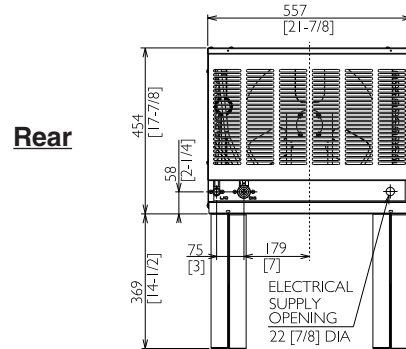
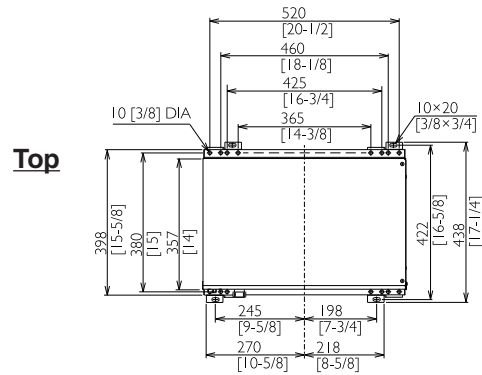

II. Installation and Operating Instructions

⚠ WARNING

- The icemaker must be installed in accordance with applicable national, state, and local codes and regulations.
- Failure to install, operate, and maintain the icemaker in accordance with this manual will adversely affect safety, performance, component life, and warranty coverage and may result in costly water damage.
- **CHOKING HAZARD:** Ensure all components, fasteners, and thumbscrews are securely in place after installation. Make sure that none have fallen into the dispenser unit/ice storage bin.

A. Location

NOTICE

- The icemaker is not intended for outdoor use. Normal operating ambient temperature must be within 45°F to 100°F (7°C to 38°C); Normal operating water temperature must be within 45°F to 90°F (7°C to 32°C). Operation of the icemaker, for extended periods, outside of these normal temperature ranges may affect icemaker performance.
- The icemaker will not work at sub-freezing temperatures. To prevent damage to the water supply line, drain the icemaker if the air temperature is going to go below 32°F (0°C). See "IV. Preparing the Appliance for Periods of Non-Use."

- The icemaker should not be located next to ovens, grills, or other high heat producing equipment.
- Allow 6" (15 cm) clearance at rear, sides, and top for proper air circulation and ease of maintenance and/or service should they be required.
- The location should provide a firm and level foundation for the equipment.

B. Checks Before Installation

- Visually inspect the exterior of the shipping container and immediately report any damage to the carrier. Upon opening the container, any concealed damage should also be immediately reported to the carrier.
- Remove the shipping carton, tape, and packing material. If any are left in the icemaker, it will not work properly.
- See the nameplate on the rear panel, and check that your voltage supplied corresponds with the voltage specified on the nameplate.
- Remove the panels to prevent damage when installing the icemaker. See "II.C. How to Remove Panels."
- Remove the package containing the accessories.
- Remove the protective plastic film from the panels. If the icemaker is exposed to the sun or to heat, remove the film after the icemaker cools.
- Check that the refrigerant lines do not rub or touch lines or other surfaces, and that the fan blade (if applicable) turns freely.
- Check that the compressor is snug on all mounting pads.
- The icemaker can be installed on a dispenser unit or ice storage bin. The ice storage bins listed below are recommended.

Model Number	Bin Width	Recommended Hoshizaki Ice Storage Bin
KM-350M_J	22" or Wider	B-300 Series
KM-520M_J		
KM-660M_J		

For further options, contact your local Hoshizaki distributor.

- **NOTICE!** Remote models must be connected to an appropriate remote condenser unit. The remote condenser units listed below are recommended. Connection to a different remote condenser unit will void the warranty unless Hoshizaki approves a different remote condenser unit for your specific application. For further details, contact your local Hoshizaki distributor.

Model Number	Recommended Hoshizaki Remote Condenser Unit
KM-520MRJ	URC-5F
KM-660MRJ	

C. How to Remove Panels

See Fig. 1

- Front Panel: Remove the screw. Lift up and towards you.
- Top Panel: Lift up at front slightly, push rearward and lift off.
- Right Side Panel: Remove the screw. Slide the right front corner to the right slightly, then push rearward and lift off.
- Front Insulation Panel: Lift up slightly and pull towards you.
- Base Cover: Lift up slightly and pull towards you.

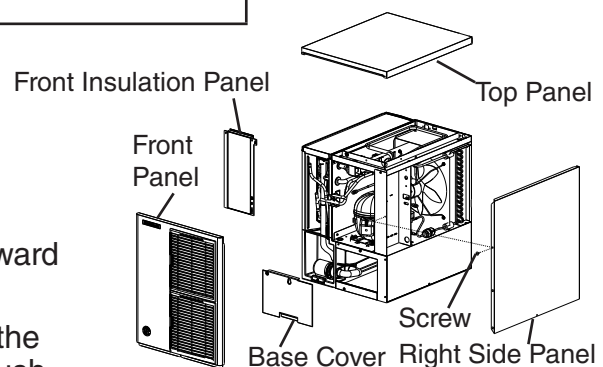

Model Shown: KM-520MAJ

Fig. 1

D. Setup

1. Dispenser Unit/Ice Storage Bin and Icemaker Setup

⚠ WARNING

- The installer must ensure the dispenser unit/ice storage bin is compatible with the icemaker, and the dispenser unit/ice storage bin and icemaker are properly attached and secured.
- Do not allow top kits to interfere with the bin control lens sensing area or the icemaker will not operate properly.

- 1) If mounting the icemaker on top of a dispenser unit, follow the dispenser unit's setup procedure. If mounting the icemaker on top of an ice storage bin, unpack the ice storage bin and attach the 4 adjustable legs provided (bin accessory) to the bottom of the ice storage bin.
 - 2) Position the dispenser unit/ice storage bin in its permanent location.
 - 3) If required, install an adapter kit or top kit. Contact your local Hoshizaki distributor for recommendations.
 - 4) Level the dispenser unit/ice storage bin in both the left-to-right and front-to-rear directions. If using an ice storage bin, adjust the ice storage bin legs to level.
 - 5) Place the icemaker on top of the dispenser unit/ice storage bin.
- 6a) **Dispenser Unit:** Follow the dispenser unit, adapter kit, or top kit instructions for securing the icemaker. If no instructions are available, secure the icemaker using the mounting brackets provided. Rotate the mounting brackets so that they fit flush to the dispenser unit. See Fig. 2a. Secure the mounting brackets to the icemaker with the bolts provided. Secure the mounting brackets to the dispenser unit with self-tapping screws (not provided). **NOTICE! Use care to avoid damage to dispenser unit components when attaching the mounting brackets. For dispenser unit bin control setting see "II.J. Bin Control Check and Setting."**
- 6b) **Ice Storage Bin:** Follow the ice storage bin, adapter kit, or top kit instructions for securing the icemaker. If no instructions are available, secure the icemaker using the 2 mounting brackets and the bolts provided. See Fig. 2b.

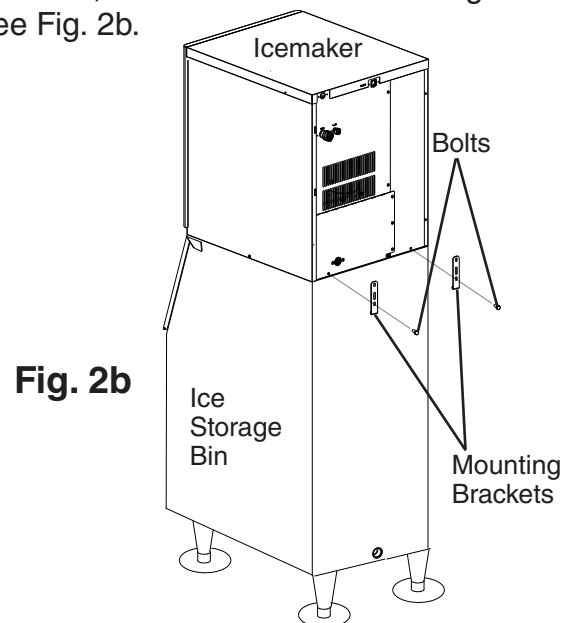
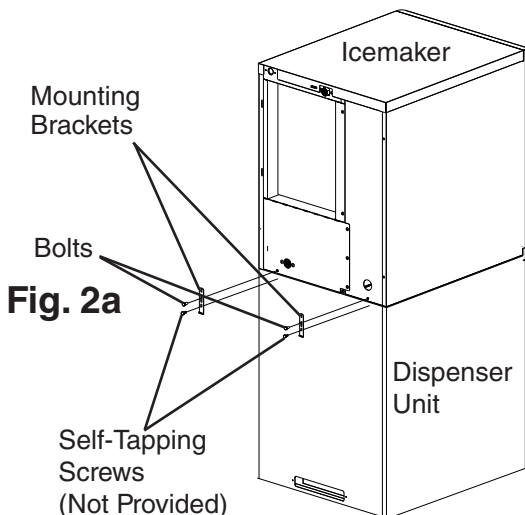

E. Electrical Connection

⚠ WARNING

For All Models

- Electrical connection must be hard-wired and must meet national, state, and local electrical code requirements. Failure to meet these code requirements could result in death, electric shock, serious injury, fire, or damage.
- The icemaker requires an independent power supply of proper capacity. See the nameplate for electrical specifications. Failure to use an independent power supply of proper capacity can result in a tripped breaker, blown fuse, damage to existing wiring, or component failure. This could lead to heat generation or fire.
- **THE ICEMAKER MUST BE GROUNDED.** Failure to properly ground the icemaker could result in death or serious injury.
- Electrical connection must be made in accordance with the instructions on the "WARNING" tag, provided with the pig tail leads. See Fig. 3.

Additional Warnings for Remote Models

- **THE REMOTE CONDENSER UNIT MUST BE GROUNDED.** Power supply and ground connection to the remote condenser unit are supplied from the icemaker. See "II.G.6. Electrical Connection." Failure to properly ground the remote condenser unit could result in death or serious injury.
- To reduce the risk of electric shock, make all remote condenser unit connections before connecting the icemaker power supply.

NOTICE

On remote models, the appliance must have power for a minimum of 4 hours prior to startup to prevent compressor damage.

- Usually an electrical permit and services of a licensed electrician are required.
- The maximum allowable voltage variation is ± 10 percent of the nameplate rating.
- On 115/60/1 models, the white lead must be connected to the neutral conductor of the power source. **NOTICE! Miswiring may result in severe damage to the icemaker.**
- The opening for the power supply connection is 7/8" DIA to fit a 1/2" trade size conduit.

KM-350M_J
KM-520M_J
KM-660M_J

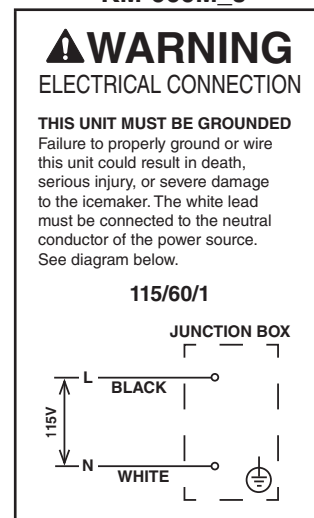

Fig. 3

F. Water Supply and Drain Connections

See Figs. 4 through 6

⚠ WARNING

Water supply and drain connections must be installed in accordance with applicable national, state, and local regulations.

NOTICE

- Normal operating water temperature should be within 45°F to 90°F (7°C to 32°C). Operation of the appliance, for extended periods, outside of this normal temperature range may affect appliance performance.
- Water supply pressure must be a minimum of 10 PSIG and a maximum of 113 PSIG. If the pressure exceeds 113 PSIG, the use of a pressure reducing valve is required.
- To prevent damage to the appliance, do not operate the appliance when the water supply is off, or if the pressure is below 10 PSIG. Do not run the appliance until the proper water pressure is reached.
- External filters, strainers, or softeners may be required depending on water quality. Contact your local Hoshizaki Certified Service Representative or local Hoshizaki distributor for recommendations.

- A plumbing permit and services of a licensed plumber may be required in some areas.
- The icemaker drain line, dispenser unit/ice storage bin drain line, and water-cooled condenser drain line (if applicable) must be run separately. The condensation drain line can be connected to the icemaker drain line or can be run separately.
- Drain lines must have 1/4" fall per foot (2 cm per 1 m) on horizontal runs to get a good flow. A vented tee connection is also required for proper flow.
- Drain lines should not be piped directly to the sewer system. An air gap of a minimum of 2 vertical inches (5 cm) should be between the end of the drain pipes from the icemaker and condensation drain, dispenser unit/ice storage bin, and water-cooled condenser (if applicable) and the floor drain.

1. Icemaker

Icemaker Water Supply Inlet	Minimum Icemaker Water Supply Line Size	Icemaker Drain Outlet	Minimum Icemaker Drain Line Size	Condensation Drain Outlet
1/2" Female Pipe Thread (FPT)	1/4" Nominal ID Copper Water Tubing or Equivalent	3/4" Female Pipe Thread (FPT)	3/4" Nominal ID Hard Pipe or Equivalent	3/8" OD Hard Tube

- An icemaker water supply line shut-off valve and drain valve must be installed.
- Be sure there is sufficient extra water supply line and drain line for the appliance to be pulled out for service.

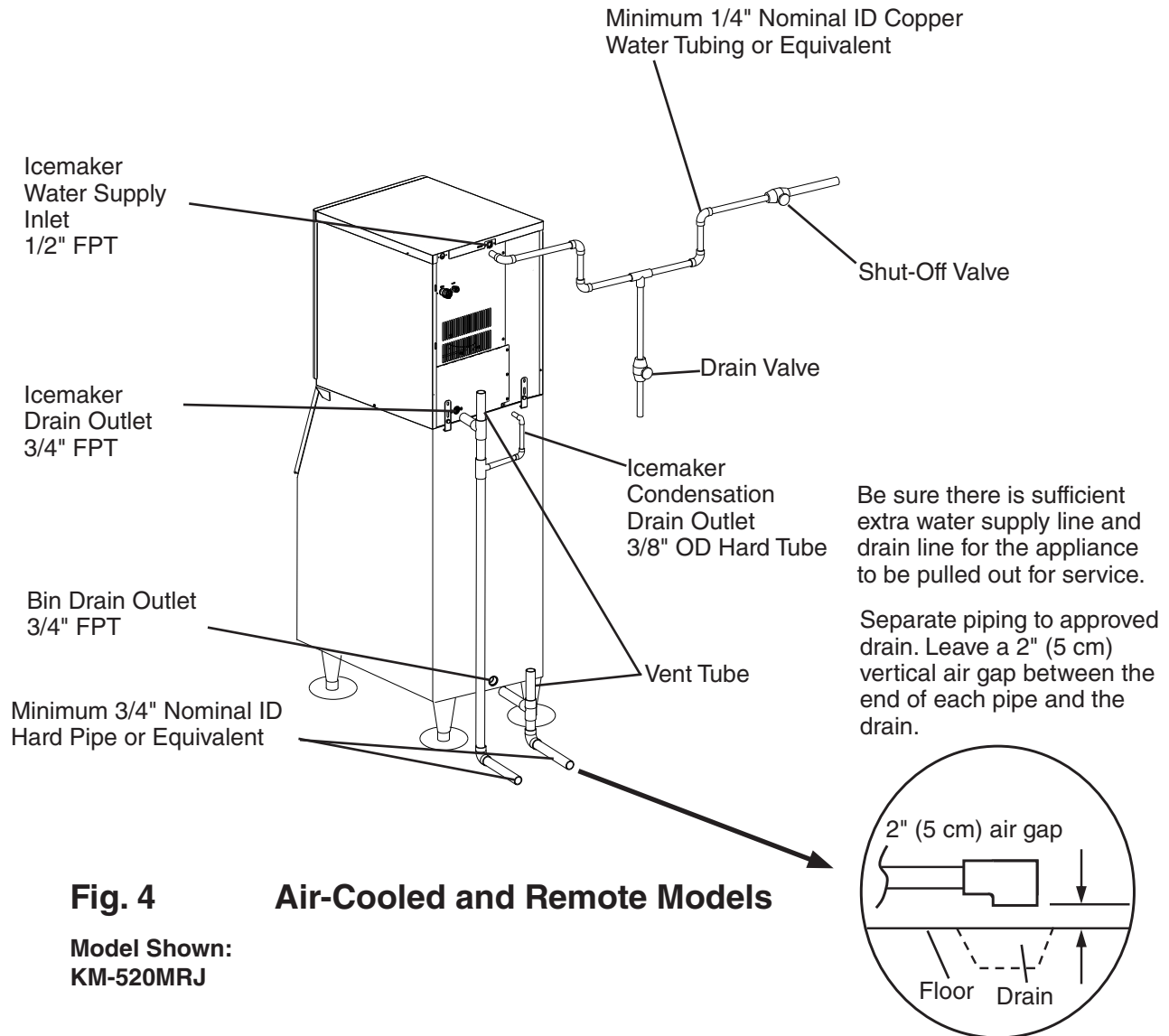

2. Water-Cooled Condenser

a) Connection to an Open Drain System

Condenser Water Supply Inlet	Minimum Condenser Water Supply Line Size	Condenser Drain Outlet	Minimum Condenser Drain Line Size
1/2" Female Pipe Thread (FPT)	1/4" Nominal ID Copper Water Tubing or Equivalent	3/8" Female Pipe Thread (FPT)	1/4" Nominal ID Hard Pipe or Equivalent

- A condenser water supply line shut-off valve and drain valve must be installed.
- In some areas, a back flow preventer may be required in the cooling water circuit.
- In order to maintain the proper high side pressure, the condenser water supply inlet temperature should not drop below 45°F (7°C) and the condenser drain outlet temperature must be in the 104°F to 115°F (40°C to 46°C) range. Once the icemaker installation is complete, confirm the condenser drain outlet temperature 5 minutes after a freeze cycle starts. If the condenser drain outlet temperature is not in the proper range, use a flat blade screwdriver to rotate the adjustment screw on the water-regulating valve until the temperature is in the proper range (rotate counterclockwise to raise temperature or clockwise to lower temperature).

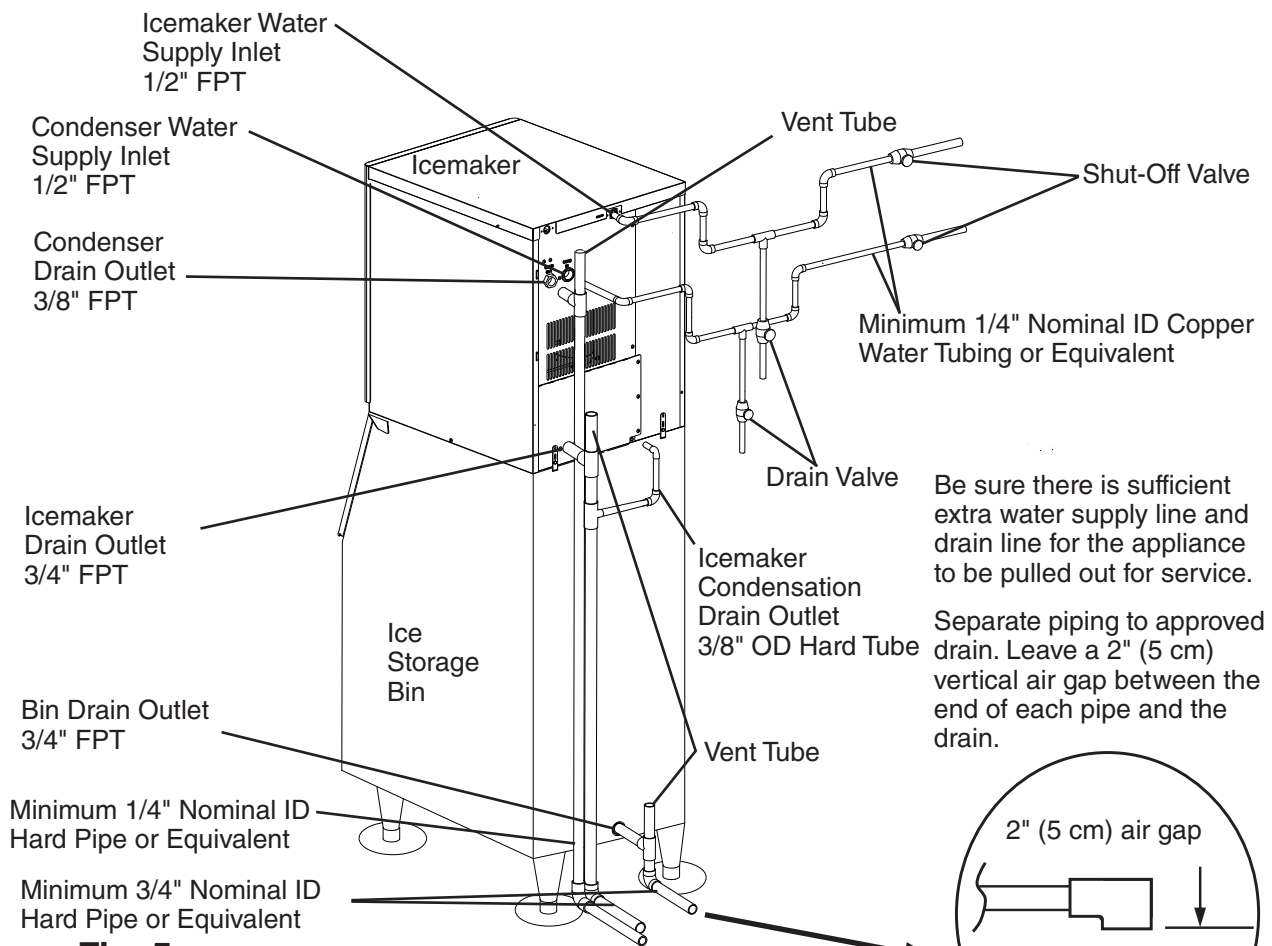

Fig. 5

Model Shown:
KM-520MWJ

Water-Cooled Models Connection to an Open Drain System

b) Connection to a Closed Loop System

Condenser Water Supply Inlet	Minimum Condenser Water Supply Line Size	Condenser Return Outlet	Minimum Condenser Return Line Size
1/2" Female Pipe Thread (FPT)	1/4" Nominal ID Copper Water Tubing or Equivalent	3/8" Female Pipe Thread (FPT)	1/4" Nominal ID Copper Water Tubing or Equivalent

- Shut-off valves and drain valves must be installed at both the condenser water supply inlet and condenser return outlet.
- Minimum water flow to the condenser is 4 GPM.
- The pressure differential between the condenser water supply inlet and condenser return outlet must be no less than 10 PSIG.
- When using a glycol blend, the solution mixture should be less than 30% glycol.
- In order to maintain the proper high side pressure, the condenser water supply inlet temperature should not drop below 45°F (7°C) and the condenser return outlet temperature must be in the 104°F to 115°F (40°C to 46°C) range. Once the icemaker installation is complete, confirm the condenser return outlet temperature 5 minutes after a freeze cycle starts. If the condenser return outlet temperature is not in the proper range, use a flat blade screwdriver to rotate the adjustment screw on the water-regulating valve until the temperature is in the proper range (rotate counterclockwise to raise temperature or clockwise to lower temperature).

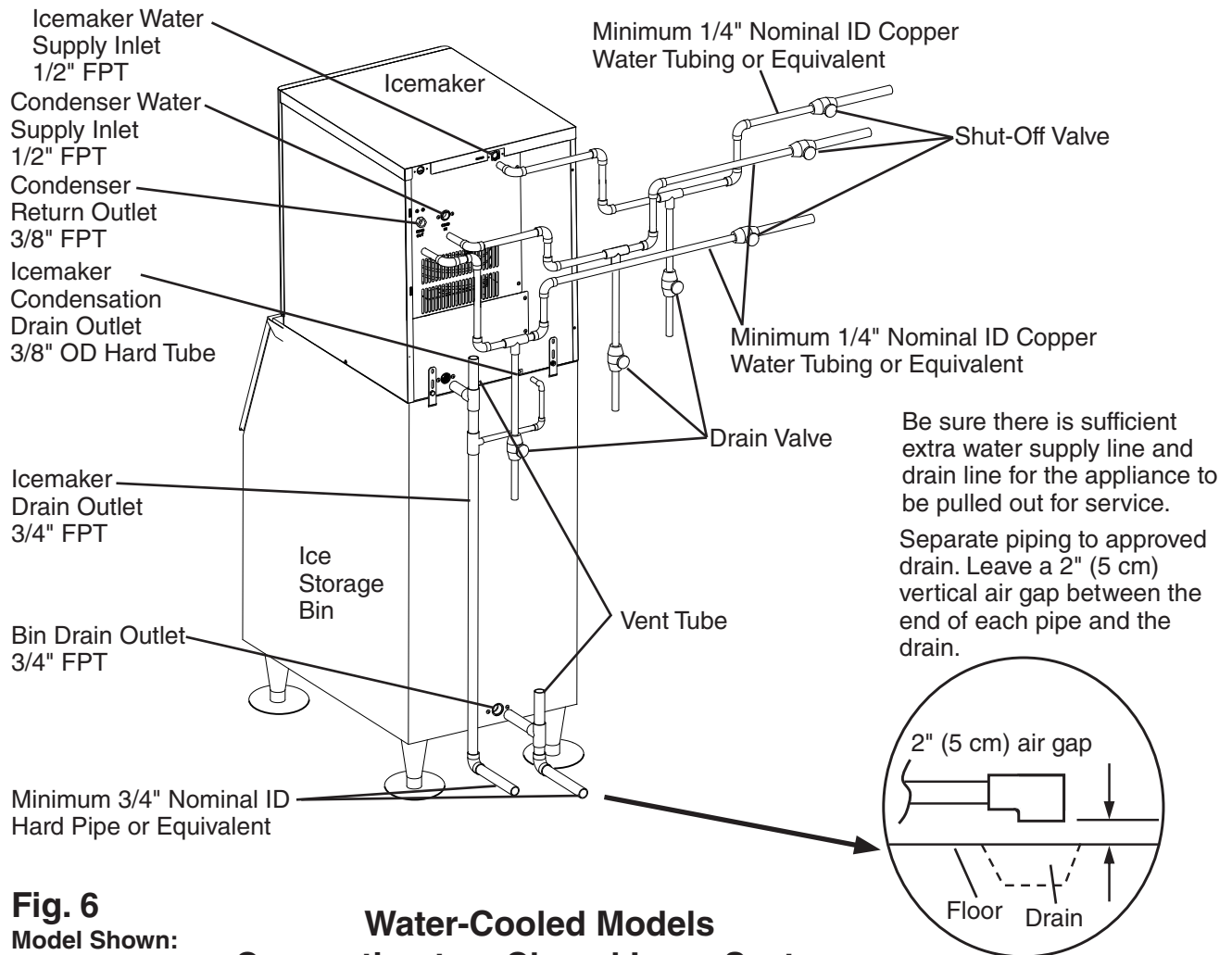

Fig. 6
Model Shown:
KM-660MWJ

Water-Cooled Models
Connection to a Closed Loop System

G. Remote Condenser Unit Installation

⚠ WARNING

- Installation of remote condenser unit must be performed by properly trained and EPA-certified service personnel.
- The remote condenser unit must be installed in accordance with applicable national, state, and local codes and regulations.
- Failure to install the remote condenser unit within these guidelines may adversely affect safety, performance, component life, and warranty coverage.
- Power supply and ground wire to the remote condenser unit are supplied from the icemaker. For details, see section "II.G.6. Electrical Connection."

1. Location

NOTICE

- The remote condenser unit is intended for outdoor use. Normal operating ambient temperature must be within -20°F to $+122^{\circ}\text{F}$ (-29°C to $+50^{\circ}\text{C}$). Operation of the remote condenser unit, for extended periods, outside of this normal temperature range may affect appliance performance.
- The maximum line length for the standard line sizes and refrigerant charge is 66' (20 m). With larger line sizes and/or additional refrigerant, the maximum line length is 100' (30.5 m). For details, see "II.G.4 Line Set Size and Refrigerant Charge."
- The maximum vertical distance between the remote condenser unit and the icemaker is 33' (10 m) above or 10' (3 m) below the icemaker. These distances are measured fitting to fitting. See Fig. 7.

The remote condenser unit must be positioned in a permanent site under the following guidelines:

- A firm and flat site.
- A dry and well ventilated area with 24" (61 cm) clearance at front and rear for proper air circulation and ease of maintenance and/or service should they be required. See Fig. 8.

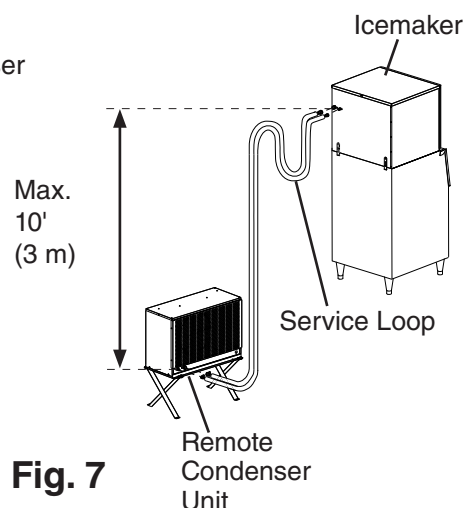
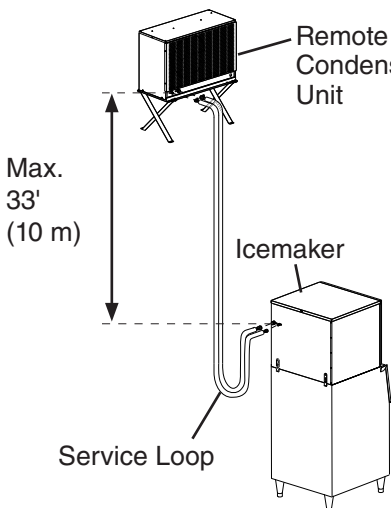

Fig. 7

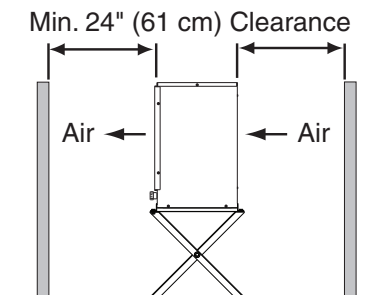

Fig. 8

2. Checks Before Installation

- 1) Remove the shipping carton, tape, and packing material.
- 2) Check that the refrigerant lines do not rub or touch lines or other surfaces, and that the fan blades move freely.

3. Setup

- 1) Assemble 2 sets of legs using the legs, bolts, and nuts provided. See Fig. 9.
- 2) Position 1 of the plates provided between a set of legs and the remote condenser unit, then secure the legs to the remote condenser unit with the bolts and nuts provided. Repeat on the other side with the remaining set of legs.
- 3) The bottom of each leg has a mounting hole. Secure the legs to the permanent site with 4 bolts (not included).

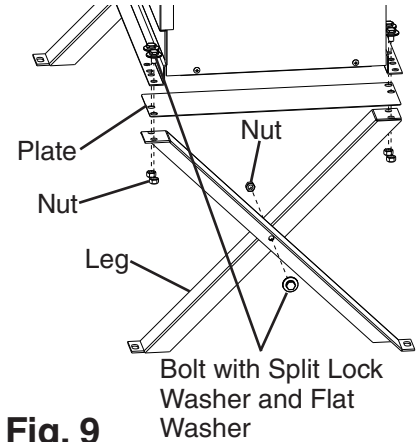

Fig. 9

4. Line Set Size and Refrigerant Charge

NOTICE

The icemaker, line set, and remote condenser unit must contain the same type of refrigerant. Mixing of refrigerants will result in improper operation and possible damage to the refrigeration system.

Line Set Size and Refrigerant Charge							
Hoshizaki Icemaker	Hoshizaki Remote Condenser Unit	Line Set Up to 66' (20 m)			Line Set Greater than 66' (20 m) Maximum 100' (30.5 m)		
		Liquid Line	Discharge Line	Charge Adjustment	Liquid Line	Discharge Line	Charge Adjustment (R-404A)
KM-520MRJ KM-660MRJ	URC-5F	1/4" OD	3/8" OD	Not Applicable	3/8" OD	1/2" OD	Add 16.5 oz. (468 g) to compensate for larger diameter line sizes, then add 0.4 oz. for each foot over 66' (40 g for each meter over 20 m). Write new total charge on icemaker's rating label.

5. Line Set Installation

Precharged factory line sets, available as optional equipment from Hoshizaki America, are recommended. For details, see "II.G.5.a) Factory Line Set Installation." Field fabricated line sets are allowed. For details, see "II.G.5.b) Field Fabricated Line Set Installation."

a) Factory Line Set Installation

- 1) Route the factory line set (see "II.G.4 Line Set Size and Refrigerant Charge" for details) from the remote condenser unit to the icemaker. Leave a service loop behind the icemaker to allow the icemaker to be pulled out for service. See Fig. 10. Factory fabricated line sets are precharged and do not need to be evacuated. If the line set is too long or too short, see "II.G.5.a)(1) Factory Line Set Modification."

NOTICE

- Ensure that there are no traps and no kinks in the line set. The service loop is not considered an oil trap.
- Do not coil extra line set.

- 2) Connect the refrigerant lines to the appropriate male fittings on the remote condenser unit first and then at the icemaker. Make a proper connection as follows:
 - a. Remove the protective covers from the male fitting and female coupling.
 - b. Apply Polyol Ester (POE) refrigerant oil or Parker Super O Lube to the entire male fitting, including O-ring, diaphragm, and threads before making the connection. See Fig. 11. **NOTICE! Do not use thread sealant on the fittings. Use POE refrigerant oil or Parker Super O Lube only. Couplings are one-time use only.**
 - c. Make sure the male fitting and female coupling are properly aligned, then start the connection by hand to ensure that it is not cross threaded.
 - d. Place a backup wrench on the back of the female coupling, then tighten the connection with a wrench until it is tight. At this point, the nut has covered most of the threads on the male fitting. **NOTICE! Failure to use a backup wrench may result in damage to the line set and possible refrigerant leaks.**
 - e. Mark a reference line on the female coupling and the remote condenser unit or icemaker panel. Using a backup wrench on the back of the female coupling, tighten the six-sided nut of the female coupling an additional 1/6 turn. See Fig. 12. **NOTICE! Confirm connection is free of leaks.**
- 3) If you lengthened the line set as outlined in "II.G.5.a)(1) Factory Line Set Modification" and it exceeds 66' (20 m), see "II.G.4. Line Set Size and Refrigerant Charge" for proper charging of the appliance.

(1) Factory Line Set Modification

- 1) Recover the line set charge through the Schrader access ports on the Parker quick connect couplings and store it in an approved container. Do not discharge the refrigerant into the atmosphere. Remove the extra line set length or add extra tubing. When adding extra tubing, insulate the additional copper tubes separately.
- 2) Use an electronic leak detector or soap bubbles to check for leaks. Add a trace of refrigerant to the lines through the Schrader access ports on the Parker quick connect couplings (if using an electronic leak detector), and then raise the pressure using nitrogen gas (140 PSIG). **WARNING! Do not use R-404A as a mixture with pressurized air for leak testing.**
- 3) Evacuate through the Schrader access ports on the Parker quick connect couplings and charge with R-404A refrigerant vapor to a pressure of 15 to 30 PSIG. Go to step 2 in "II.G.5.a) Factory Line Set Installation."

b) Field Fabricated Line Set Installation

⚠ WARNING

- R-404A itself is not flammable at atmospheric pressure and temperatures up to 176°F (80°C).
- R-404A itself is not explosive or poisonous. However, when exposed to high temperatures (open flames), R-404A can be decomposed to form hydrofluoric acid and carbonyl fluoride both of which are hazardous.
- Do not use silver alloy or copper alloy containing arsenic.
- Use an electronic leak detector or soap bubbles to check for leaks. Add a trace of refrigerant to the line set tubing through the service valve access ports (if using an electronic leak detector), and then raise the pressure using nitrogen gas (140 PSIG). Do not use R-404A as a mixture with pressurized air for leak testing.

- 1) Route the copper tube liquid line and copper tube discharge line (see "II.G.4 Line Set Size and Refrigerant Charge" for details) from the remote condenser unit to the icemaker. Leave a service loop behind the icemaker to allow the icemaker to be pulled out for service. See Fig. 10.

Note: • The service loop is not considered an oil trap.

- The maximum line length for the standard line sizes and refrigerant charge is 66' (20 m). With larger line sizes and/or additional refrigerant, the maximum line length is 100' (30.5 m). For details, see "II.G.4 Line Set Size and Refrigerant Charge.

NOTICE

- Ensure that there are no traps and no kinks in the line set. The service loop is not considered an oil trap.
- Do not coil extra line set.

- 2) Remove any extra line set length, then insulate the two copper tubes separately.

- 3) Install (braze) Parker quick connect couplings on each end. OS-QUICK, a universal quick connect coupling kit available as optional equipment from Hoshizaki America, is recommended.

NOTICE

- Before brazing, remove the Schrader valve core from the access port.
- When brazing, protect the coupling by using a wet cloth to prevent the coupling from overheating.
- Braze all fittings while purging with nitrogen gas flowing at a pressure of 3 to 4 PSIG.

- 4) Allow the coupling to cool, then replace the Schrader valve core. Attach the gauge manifold hoses.
- 5) Use an electronic leak detector or soap bubbles to check for leaks. Add a trace of refrigerant to the lines through the Schrader access ports on the Parker quick connect couplings (if using an electronic leak detector), and then raise the pressure using nitrogen gas (140 PSIG). **WARNING! Do not use R-404A as a mixture with pressurized air for leak testing.**
- 6) After checking the line set for leaks, vent the nitrogen charge from the line set.
- 7) Evacuate the line set. Allow the vacuum pump to pull down to a 29.9" Hg vacuum. Evacuating period depends on pump capacity.
- 8a) **Line Set up to 66' (20 m):** After evacuation, charge each line set tube with R-404A vapor to a pressure of 15 to 30 PSIG.
- 8b) **Line Set Over 66' (20 m):** After evacuation, add the appropriate amount of additional R-404A. See "II.G.4 Line Set Size and Refrigerant Charge" for details. Hoshizaki Technical Support is available at 1-800-233-1940 for recommendations.
- 9) Close both gauge manifold valves, remove the gauge manifold hoses, then replace and tighten the access port cap.

- 10) Connect the refrigerant lines to the appropriate male fittings on the remote condenser unit first and then at the icemaker. Make a proper connection as follows:
- Remove the protective covers from the male fitting and female coupling.
 - Apply Polyol Ester (POE) refrigerant oil or Parker Super O Lube to the entire male fitting, including O-ring, diaphragm, and threads, before making the connection. See Fig. 11. **NOTICE! Do not use thread sealant on the fittings. Use POE refrigerant oil or Parker Super O Lube only. Couplings are one-time use only.**
 - Make sure the male fitting and female coupling are properly aligned, then start the connection by hand to ensure that it is not cross threaded.
 - Place a backup wrench on the back of the female coupling, then tighten the connection with a wrench until it is tight. At this point, the nut has covered most of the threads on the male fitting. **NOTICE! Failure to use a backup wrench may result in damage to the line set and possible refrigerant leaks.**
 - Mark a reference line on the female coupling and the remote condenser unit or icemaker panel. Using a backup wrench on the back of the female coupling, tighten the six-sided nut of the female coupling an additional 1/6 turn. See Fig. 12. **NOTICE! Confirm connection is free of leaks.**

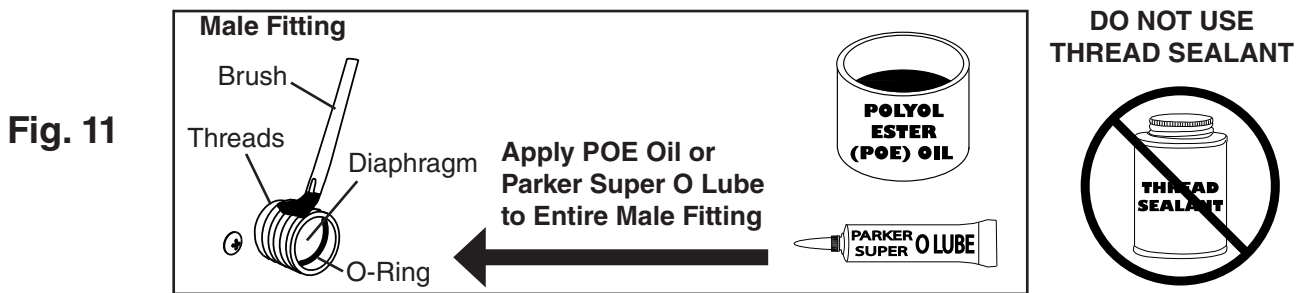
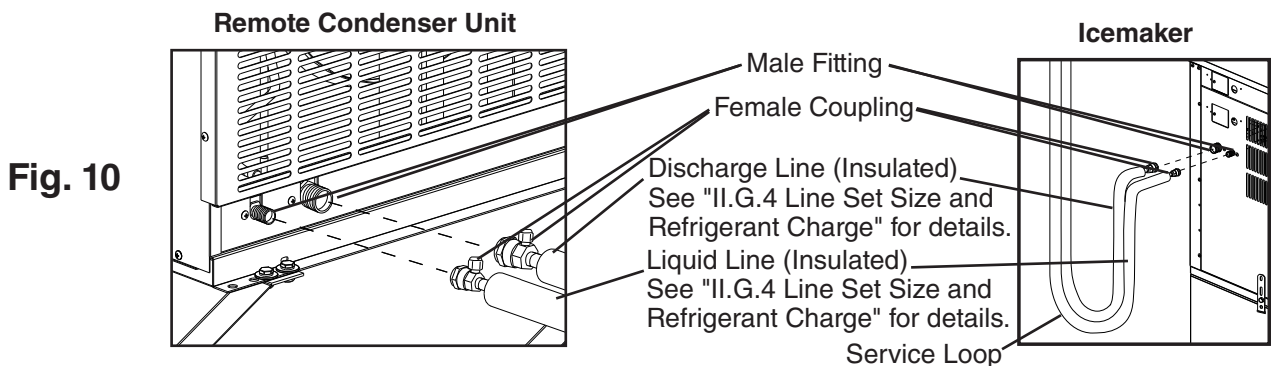

6. Electrical Connection

⚠ WARNING

- Electrical connection must meet national, state, and local electrical code requirements. Failure to meet these code requirements could result in death, electric shock, serious injury, fire, or damage.
- To reduce the risk of electric shock, make all remote condenser unit connections before connecting the icemaker power supply.
- **THE REMOTE CONDENSER UNIT MUST BE GROUNDED.** Install a ground wire from the icemaker fan motor junction box to the remote condenser unit junction box. Use wire of an appropriate gage and outdoor rating. Failure to properly ground the remote condenser unit could result in death or serious injury.
- Install line and neutral wires from the fan motor leads in the icemaker fan motor junction box to the leads in the remote condenser unit junction box. Use wire of an appropriate gage and outdoor rating.
- Do not connect the fan motor leads in the icemaker to incoming power source. Do not connect the fan motor leads in the icemaker together. Do not allow the leads to contact the junction box walls.
- Do not connect the remote condenser unit to an external power source.

NOTICE

On remote models, the appliance must have power for a minimum of 4 hours prior to startup to prevent compressor damage.

- Usually an electrical permit and services of a licensed electrician are required.
- The opening for the power supply connection is 7/8" DIA to fit a 1/2" trade size conduit.
 - 1) Remove the remote condenser unit louver panel. See Fig. 13.
 - 2) Remove the icemaker fan motor junction box cover. Remove the remote condenser unit junction box cover.

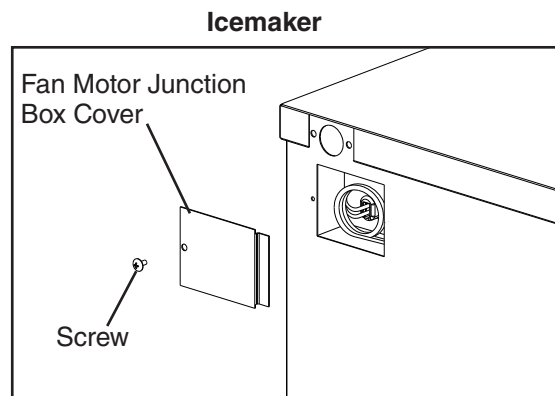
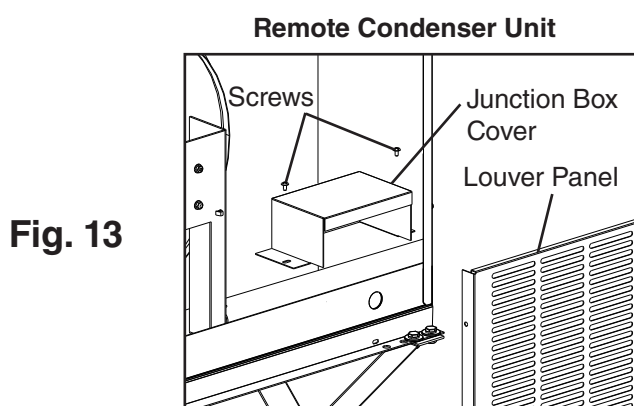

- 3) Install a ground wire from the icemaker fan motor junction box to the remote condenser unit junction box. Use wire of an appropriate gage and outdoor rating.
- 4) Install line and neutral wires from the fan motor leads in the icemaker fan motor junction box to the leads in the remote condenser unit junction box. Use wire of an appropriate gage and outdoor rating.
- 5) Replace the junction box covers and the louver panel in their correct positions.

7. Stacking Remote Condenser Unit

- 1) Install the lower remote condenser unit as described earlier in this section.
- 2) Place the upper remote condenser unit on top of the lower remote condenser unit. See Fig. 14.
- 3) Secure the upper remote condenser unit to the lower remote condenser unit with the 4 screws provided.
- 4) Install refrigerant lines and make electrical connection as described earlier in this section.

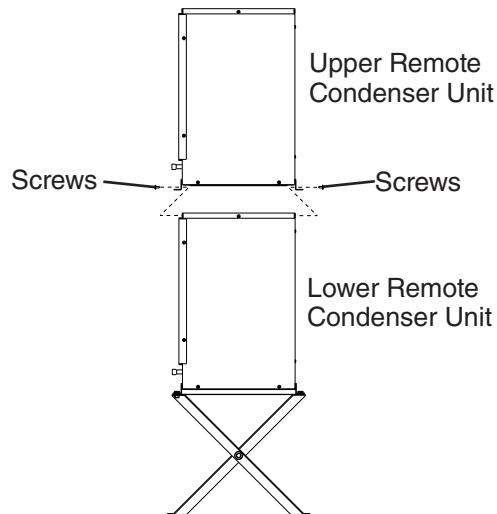

Fig. 14

H. Final Checklist

1. Pre-Startup

- 1) Is the icemaker level?
- 2) Is the icemaker in a site where the ambient temperature is within 45°F to 100°F (7°C to 38°C) and the water temperature within 45°F to 90°F (7°C to 32°C) all year around?
- 3) Is there at least 6" (15 cm) clearance at rear, sides, and top of the icemaker?
- 4) Have the shipping carton, tape, and packing material been removed from the icemaker?
Is the cube guide in the correct position?
- 5) Have all electrical and water connections been made? Do electrical and water connections meet applicable national, state, and local code and regulation requirements?
- 6) Has the power supply voltage been checked or tested against the nameplate rating?
Has a proper ground been installed to the icemaker? On remote models, has a proper ground also been installed to the remote condenser unit?
- 7) Are the water supply and drain lines sized as specified? Are the water supply line shut-off valve(s) and drain valve(s) installed? Has the water supply pressure been checked to ensure a minimum of 10 PSIG and a maximum of 113 PSIG?
- 8) Is the compressor snug on all mounting pads? Have the refrigerant lines been checked to make sure they do not rub or touch other lines or surfaces? Has the fan blade (if applicable) been checked to make sure it turns freely?
- 9) On remote models:
 - Is the line set sized as specified, insulated, tightened, and free of leaks and kinks?
 - If the line set exceeds 66' (20 m), has the line set size (if applicable) and charge been adjusted as specified?
 - Has the appliance power supply been on for a minimum of 4 hours?
 - Is the remote condenser unit in a site where the ambient temperature is within -20°F to +122°F (-29°C to +50°C) all year around?
 - Is there at least 24" (61 cm) clearance around the remote condenser unit?

2. Post-Startup

WARNING

- **CHOKING HAZARD:** Ensure all components, fasteners, and thumbscrews are securely in place after installation. Make sure that none have fallen into the dispenser unit/ice storage bin.
- Confirm that all internal and external connections are free of leaks.

- 1) Has the bin control been set to the proper setting for the application?
- 2) Has the bin control operation been confirmed?
- 3) Are all components, fasteners, and thumbscrews securely in place?
- 4) Has the end user been given the instruction manual, and instructed on how to operate the appliance and the importance of the recommended periodic maintenance?
- 5) Has the end user been given the contact information of an authorized service agent?
- 6) Has the warranty registration been completed and submitted to the factory?

I. Startup

1. Bin Control Setting

An ultrasonic sensor is used as the bin control to control the level of ice in the dispenser unit/ice storage bin. The bin control setting must be set to match the application to avoid possible icemaker movement, water leakage, or ice overflow.

⚠ WARNING
<ul style="list-style-type: none"> • Improper adjustment may adversely affect safety, performance, component life, and warranty coverage. • On dispenser unit applications, do not increase ice level above the recommended setting listed below. Higher ice levels could result in icemaker movement, water leakage, or ice overflow.

NOTICE
Do not allow top kits or top kit risers (if applicable) to interfere with the bin control lens sensing area or the icemaker will not operate properly.

- 1) Make sure that the power supply is off. Remove the front, top, and right side panels to allow access to the control board. Also remove the base cover. See Fig. 15. Note: If front access to the control box is required, remove the control box mounting screws, then slide the control box forward and rotate the control box for access. See Fig. 16.

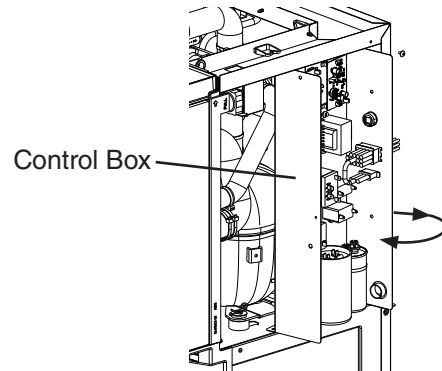
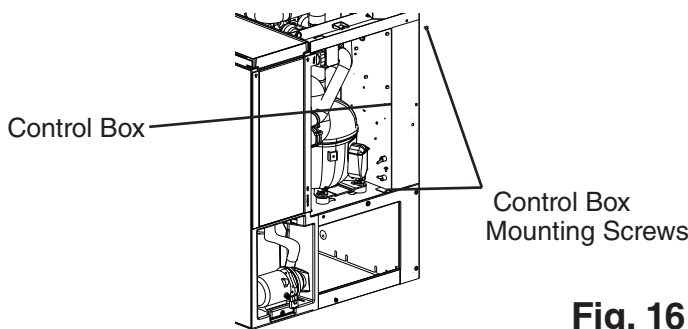
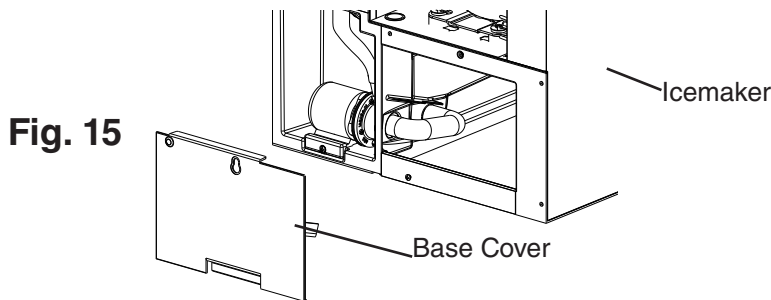

- 2) Confirm the correct control board bin control setting required for your application and adjust as detailed below.

Application	Bin Control Setting	Reference
Standard Ice Storage Bins (Factory Default)	1	See Fig. 17
Hoshizaki DB and DM Dispensers	2	
Coca-Cola Freestyle® Dispensers	3	
Non-Hoshizaki Dispensers	Measurement Required	See Fig. 18

For Standard Ice Storage Bins, Hoshizaki DB and DM Dispenser Units, and Coca-Cola

Freestyle® Dispenser Units

Application	Bin Control Ice Level Settings	
	Bin Control Setting	Shutdown Distance from Bin Control Lens (Restart is 4 in. (102 mm) below shutdown distance)
Standard Ice Storage Bins	1 (Factory Default)	254 mm (10") Do not adjust dispensers to this setting.
Hoshizaki DB and DM Dispensers	2	305 mm (12")
Coca-Cola Freestyle® Dispensers	3	406 mm (16")
Optional Setting	4	508 mm (20")
	5	610 mm (24")

⚠ WARNING

Confirm that the final ice level location does not allow for icemaker movement, water leakage, or ice overflow.

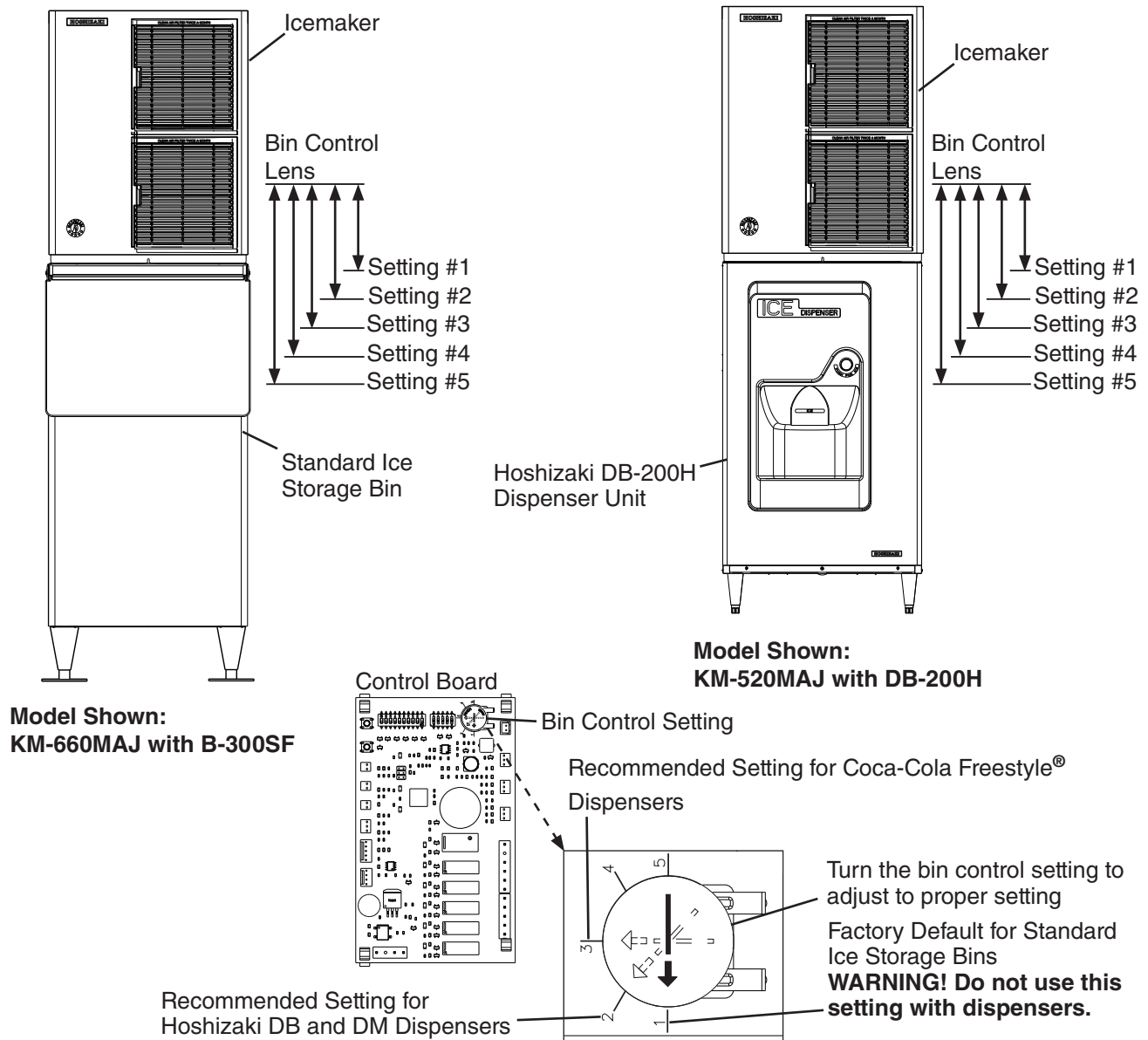

Fig. 17

For Non-Hoshizaki Dispenser Units

Bin Control Ice Level Settings	
Bin Control Setting	Shutdown Distance From Bin Control Lens (Restart is 4 in. (102 mm) below shutdown distance)
1 (Factory Default)	Do not adjust dispensers to this setting. 254 mm (10")
2	305 mm (12")
3	406 mm (16")
4	508 mm (20")
5	610 mm (24")

⚠ WARNING

Confirm that the final ice level location does not allow for icemaker movement, water leakage, or ice overflow.

NOTICE

The ice level must be lower than the top of the dispenser unit. Also, be sure the top kit or top kit riser (if applicable) are clear from the bin control lens sensing area.

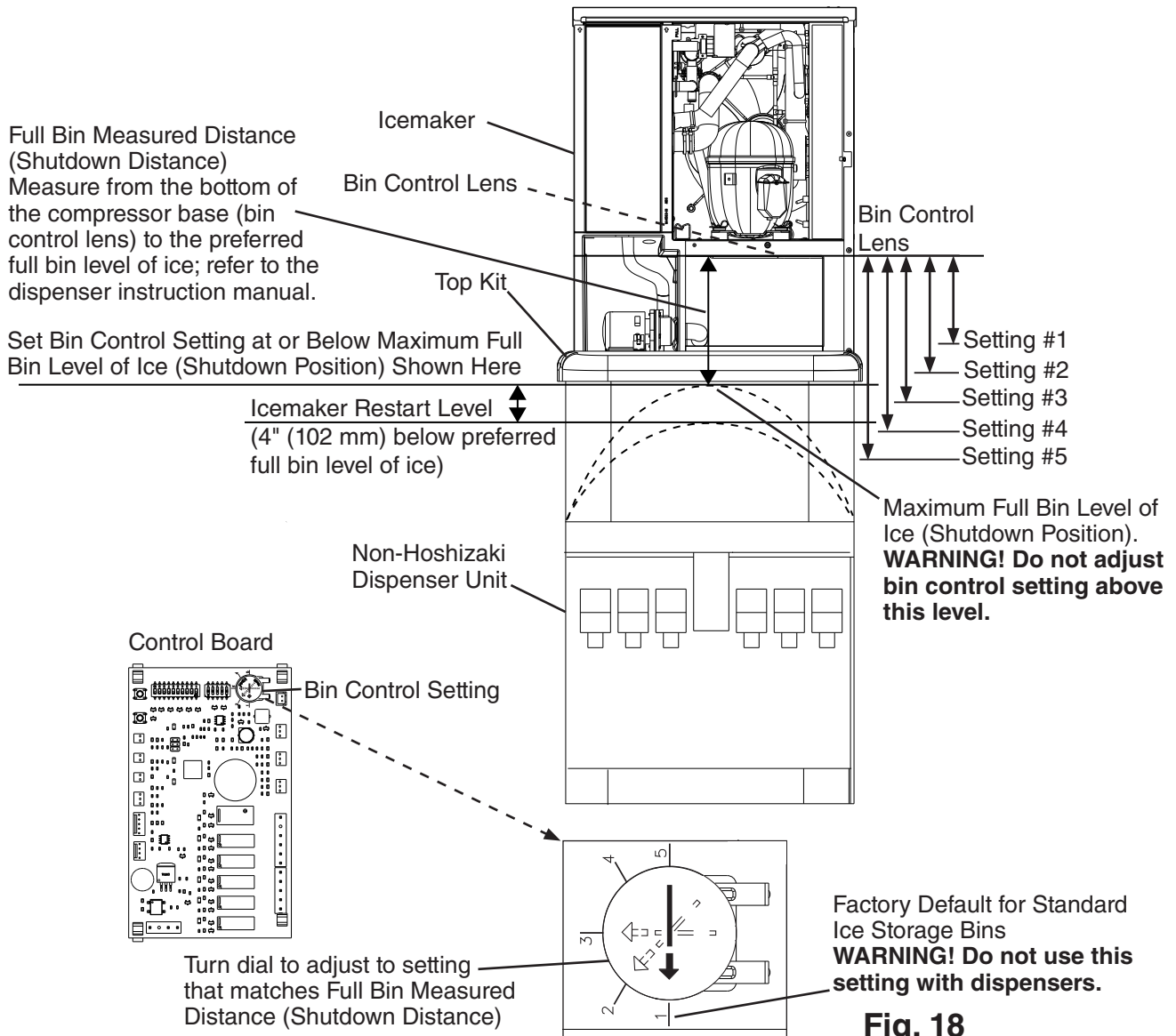

Fig. 18

2. Appliance Startup and Bin Control Check

⚠ WARNING

- All parts are factory-adjusted. Improper adjustments may adversely affect safety, performance, component life, and warranty coverage.
- Make sure the icemaker has been installed as outlined in this manual and that the water supply is on.
- Improper adjustment may adversely affect safety, performance, component life, and warranty coverage.

NOTICE

- If the icemaker is turned off, wait for at least 3 minutes before restarting the icemaker to prevent damage to the compressor.
- To prevent damage to the water pump seal, do not leave the control switch in the "PUMP" position for extended periods when the water tank is empty.
- At startup, confirm that all internal and external connections are free of leaks.
- Do not allow top kits or top kit risers (if applicable) to interfere with the bin control lens sensing area or the icemaker will not operate properly.

Additional Notice for Remote Models

- The icemaker must have power for a minimum of 4 hours prior to startup to prevent compressor damage.

- 1) If not already removed, remove the front, top, and right side panels and base cover. Make sure the bin control setting has been adjusted as outlined in "II.1.1. Bin Control Setting."
- 2) Open the water supply line shut-off valve(s).
- 3) Move the mode switch on the control box to the "ICE" position, then move the control switch to the "ON" position. Turn on the power supply, and allow the icemaker to operate.
- 4) Confirm the control board "BIN CLS" LED is off (bin empty). See Fig. 19.

Ice Level in Bin	Control Board "BIN CLS" LED
Empty	OFF
Full	ON

- 5) If the control board "BIN CLS" is on (indicating a full bin), correct any interference from the top kit or top kit riser (if applicable).

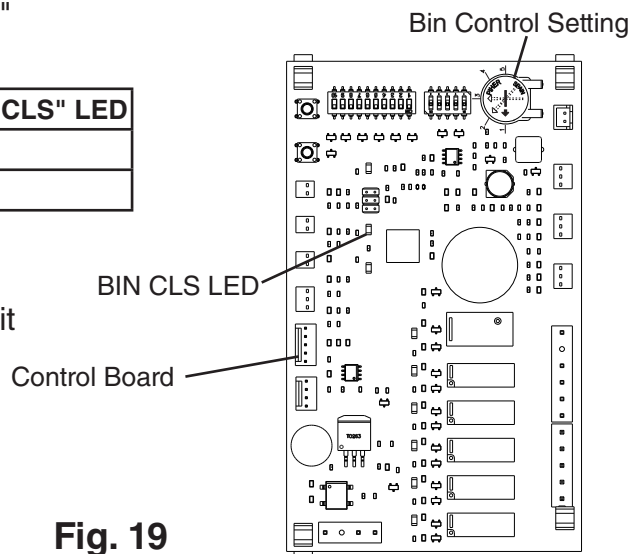

Fig. 19

- 6) 1 min. fill cycle begins. Place an object 5" to 7" (127 to 178 mm) away from the bin control lens. See Fig. 20. 15 sec. later, the icemaker shuts down. Remove the object from the bin control lens. 30 sec. later, the icemaker restarts.
For bin control shutdown times per cycle, see the table below.

Cycle at Bin Control Activation	Shutdown
1 min. Fill Cycle	15 sec. after activation.
Harvest Cycle	If engaged 15 sec. or longer, at the end of harvest cycle.
Freeze Cycle	15 sec. after activation if activated at least 15 sec. before the 5-min. short cycle protection timer terminates. Otherwise, at the end of the next harvest cycle.

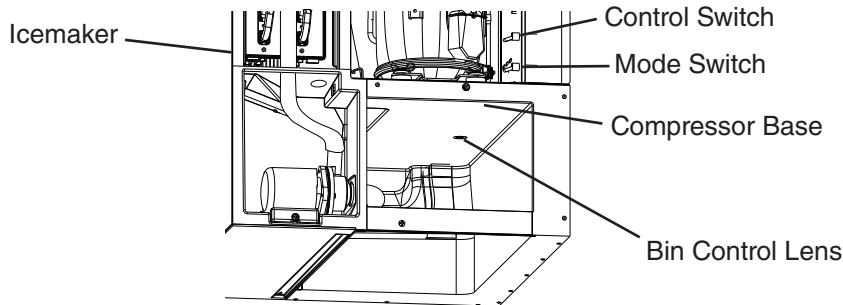

Fig. 20

- 7) Once the icemaker restarts, move the control switch to the "OFF" position, then turn off the power supply.
8) If the control box was rotated, replace the control box in its correct position and secure with the 2 control box mounting screws.
9) Replace the base cover, right side, top, and front panels in their correct positions.
10) Turn on the power supply, and allow the icemaker to operate for 10 min.
11) After 10 min., turn off the power supply, then remove the front panel.

- 12) Move the control switch to the "OFF" position, then remove the base cover and disconnect the rear pump tubing connection to drain the water tank. See Fig. 21.

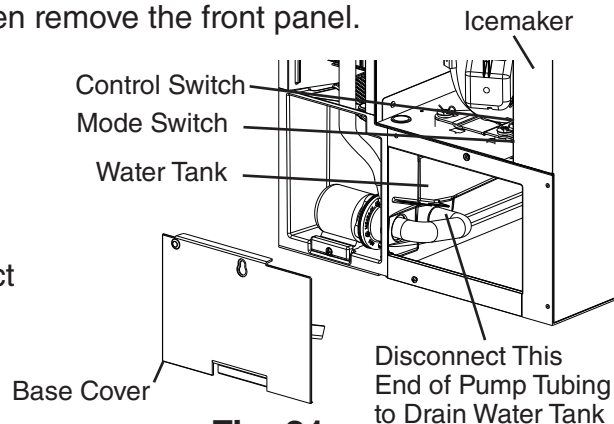

Fig. 21

- 13) After the water tank has drained, reconnect the pump tubing.
14) Clean the dispenser unit/ice storage bin liner using a neutral cleaner. Rinse thoroughly after cleaning.
15) Replace the base cover in its correct position. Move the control switch to the "ON" position. Replace all panels in their correct positions.
16) Turn on the power supply to start the automatic icemaking process.
17) On water-cooled models, confirm proper condenser drain outlet/return outlet temperature as outlined in "II.F.2. Water-Cooled Condenser."
18) Return to "II.H.2. Post-Startup" and complete final checklist.

III. Maintenance

The appliance must be maintained in accordance with the instruction manual and labels provided. Consult with your local Hoshizaki Certified Service Representative about maintenance service.

⚠ WARNING

- Only qualified service technicians should service the appliance.
- To reduce the risk of electric shock, do not touch the control switch or mode switch with damp hands.
- Move the control switch to the "OFF" position and turn off the power supply before servicing. Lockout/Tagout to prevent the power supply from being turned back on inadvertently.
- **CHOKING HAZARD:** Ensure all components, fasteners, and thumbscrews are securely in place after any maintenance is done to the appliance. Make sure that none have fallen into the dispenser unit/ice storage bin.

A. Maintenance Schedule

The maintenance schedule below is a guideline. More frequent maintenance may be required depending on water quality, the appliance's environment, and local sanitation regulations.

Maintenance Schedule		
Frequency	Area	Task
Daily	Scoop	Clean the ice scoop using a neutral cleaner. Rinse thoroughly after cleaning.
Bi-Weekly	Air Filters	Inspect. Wash with warm water and neutral cleaner if dirty.
Monthly	External Water Filters	Check for proper pressure and change if necessary.
	Icemaker Exterior	Wipe down with a clean, soft cloth. Use a damp cloth containing a neutral cleaner to wipe off oil or dirt build up. Clean any chlorine staining (rust colored spots) using a non-abrasive cleanser.
	Underside of Icemaker and Top Kits; Bin Door and Snout	Wipe down with a clean cloth and warm water.
Yearly	Icemaker and Dispenser Unit/Ice Storage Bin	Clean and sanitize per the cleaning and sanitizing instructions provided in this manual. See "III.B. Cleaning and Sanitizing Instructions."
	Water Supply Inlet	Close the icemaker water supply line shut-off valve and drain the water system. Clean the water supply inlet screen.
	Condenser	Inspect. Clean if necessary by using a brush or vacuum cleaner. More frequent cleaning may be required depending on location.
	Water Hoses	Inspect the water hoses and clean/replace if necessary.

B. Cleaning and Sanitizing Instructions

The icemaker must be cleaned and sanitized at least once a year. More frequent cleaning and sanitizing may be required in some water conditions.

⚠ WARNING

- To prevent injury to individuals and damage to the icemaker, do not use ammonia type cleaners.
- Carefully follow any instructions provided with the bottles of cleaning and sanitizing solution.
- Always wear liquid-proof gloves and goggles to prevent the cleaning and sanitizing solutions from coming into contact with skin or eyes.
- Do not leave the icemaker unattended when panels are off.

NOTICE

To prevent damage to the water pump seal, do not leave the control switch in the "PUMP" position for extended periods when the water tank is empty.

Preparation

- 1) Remove the front panel, then move the control switch to the "OFF" position. Make sure the mode switch is in the "ICE" position. After 3 minutes, move the control switch to the "ON" position and replace the front panel.
- 2) Allow the appliance to run until the compressor energizes. Once the compressor energizes, allow the appliance to run for an additional 3 minutes, then remove the front panel. Move the control switch to the "OFF" position.
- 3) Remove all ice from the dispenser unit/ice storage bin. **WARNING! If on a dispenser unit, turn off the dispenser unit power supply after dispensing the ice.**

Cleaning

- 4) Move the mode switch to the "CLEAN" position, then move the control switch to the "ON" position (1 short beep occurs, then 3 seconds later 1 long beep occurs). Replace the front panel. The water tank drains and then fills.
- 5) When the control board starts beeping (2 beep sequence), remove the front panel. Move the control switch to the "OFF" position.
- 6) Remove the front insulation panel, then pour 10.4 fl. oz. (308 ml) of Hoshizaki "Scale Away" into the water tank. Replace the front insulation panel.
- 7) Move the control switch to the "ON" position (1 short beep occurs, then 3 seconds later 1 long beep occurs). Replace the front panel. To avoid excessive foaming in the water tank, there is a 1 minute delay before circulation begins. After approximately 30 minutes of circulation, the icemaker performs 3 rinse cycles.
- 8) When the control board starts beeping (5 beep sequence), remove the front panel. Move the control switch to the "OFF" position.
- 9) In bad or severe water conditions, turn off the power supply, then remove, clean (cleaning solution = 5 oz. Hoshizaki "Scale Away" per gallon of warm water), rinse, and replace the cube guide, float switch, water supply tubes, spray tubes, and spray guides; turn on the power supply when complete. Otherwise, continue to step 10.

Sanitizing

- 10) Confirm the mode switch is in the "CLEAN" position, then move the control switch to the "ON" position (1 short beep occurs, then 3 seconds later 1 long beep occurs).
Replace the front panel. The water tank drains and then fills.
- 11) When the control board starts beeping (2 beep sequence), remove the front panel.
Move the control switch to the "OFF" position.
- 12) Remove the front insulation panel, then pour 0.6 fl. oz. (18 ml) of an 8.25% sodium hypochlorite solution (chlorine bleach) into the water tank. Replace the front insulation panel.
IMPORTANT! Use regular bleach with no additives. Using a bleach with additives causes excessive foaming during sanitizing, reducing the effectiveness of sanitizing.
- 13) Move the control switch to the "ON" position (1 short beep occurs, then 3 seconds later 1 long beep occurs). Replace the front panel. To avoid excessive foaming in the water tank, there is a 1 minute delay before circulation begins. After approximately 30 minutes of circulation, the icemaker performs 3 rinse cycles.
- 14) When the control board starts beeping (5 beep sequence), remove the front panel.
Move the control switch to the "OFF" position.
- 15) Clean the dispenser unit/ice storage bin liner using a neutral cleaner. Rinse thoroughly after cleaning.
- 16) Move the mode switch to the "ICE" position, then move the control switch to the "ON" position. Note: If on a dispenser unit, turn on the dispenser unit power supply.
- 17) Replace all panels in their correct positions.

IV. Preparing the Appliance for Periods of Non-Use

NOTICE

- When storing the icemaker for an extended time or in sub-freezing temperatures, follow the instructions below to prevent damage.
- To prevent damage to the water pump seal, do not leave the control switch in the "PUMP" position for extended periods when the water tank is empty.

When the icemaker is not used for two or three days under normal conditions, it is sufficient to move the control switch to the "OFF" position. When storing the icemaker for an extended time or in sub-freezing temperatures, follow the instructions below.

1. Remove the water from the icemaker water supply line:

- 1) Turn off the power supply, then remove the front panel.
- 2) Move the control switch to the "OFF" position.
- 3) Close the icemaker water supply line shut-off valve, then open the icemaker water supply line drain valve.
- 4) Allow the line to drain by gravity.
- 5) Attach a compressed air or carbon dioxide supply to the icemaker water supply line drain valve.
- 6) Move the mode switch to the "ICE" position, then move the control switch to the "ON" position.
- 7) Replace the front panel in its correct position, then turn on the power supply.
- 8) Blow the icemaker water supply line out using the compressed air or carbon dioxide supply.
- 9) Close the icemaker water supply line drain valve.

2. Drain the water tank:

- 1) Turn off the power supply, then remove the front panel.
- 2) Move the control switch to the "OFF" position.
- 3) Remove the base cover, then disconnect one end of the pump tubing to drain the water tank. See Fig. 22. After the water tank has drained, reconnect the pump tubing.
- 4) Remove all ice from the dispenser unit/ice storage bin. Clean the dispenser unit/ice storage bin liner using a neutral cleaner. Rinse thoroughly after cleaning.
- 5) Replace the base cover and the front panel in their correct positions.

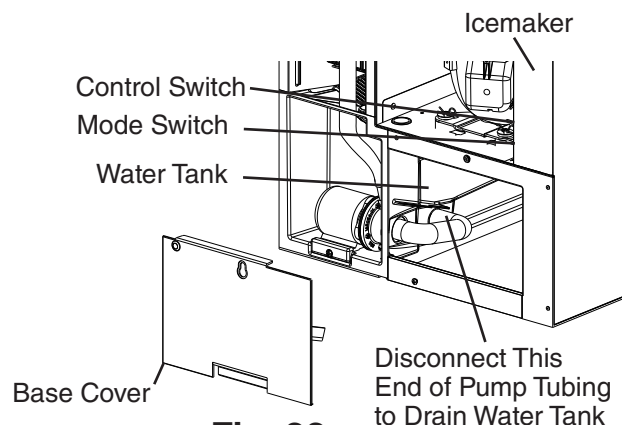

Fig. 22

3. On water-cooled models, remove the water from the water-cooled condenser:

- 1) Make sure the power supply is off, then remove the front, top, and right side panels.
- 2) Close the condenser water supply line shut-off valve. If connected to a closed loop system, also close the condenser return line shut-off valve.
- 3) Open the condenser water supply line drain valve. If connected to a closed loop system, also open the condenser return line drain valve.
- 4) Attach a compressed air or carbon dioxide supply to the condenser water supply line drain valve.
- 5) Open the water regulating valve by using a screwdriver to pry up on the spring retainer underneath the spring. While holding the valve open, blow out the condenser using the compressed air or carbon dioxide supply until water stops coming out.
- 6) Close the drain valve(s).
- 7) Replace the panels in their correct positions.

V. Disposal

The appliance contains refrigerant and must be disposed of in accordance with applicable national, state, and local codes and regulations. Refrigerant must be recovered by properly certified service personnel.

HOSHIZAKI AMERICA, INC.

618 Hwy. 74 South, Peachtree City, GA 30269 USA (P) 770.487.2331 (F) 770.487.3360 hoshizakiamerica.com 1A6547-010

Panasonic®

Owner's Manual Commercial Microwave Ovens Model No. NE-1054F



Before operating this oven, please read these instructions completely.

F0003BS80RP
IP0215-0
Printed in China

TABLE OF CONTENTS

PRECAUTIONS TO AVOID POSSIBLE EXPOSURE TO EXCESSIVE MICROWAVE ENERGY	3
IMPORTANT SAFETY INSTRUCTIONS	3
Installation and Grounding Instructions	4
Safety Precautions	5
How Does the Microwave Work?	6
Outline Diagram	7
How to Operate	8
Before Operating	8
Heating	
A. Manual Single Stage Heating	9
B. Manual 2 or 3 Stage Heating	9
C. Programmed Heating	10
Programming	
A. Programming Memory Pads for Single Stage Heating	11
B. Programming Memory Pads for 2 or 3 Stage Heating	12
C. Programming the Double Quantity Pad for Multiple Portion Heating	13
Others Features	
A. To Activate Program Lock	14
B. To Release Program Lock	14
C. To Read Program List	15
D. To Select Beep Tone Options	16
E. To Read the Cycle Counter	16
Self Diagnostics Failure Code Explanation	17
Care of Your Microwave Oven	17
Technical Specifications	18

IMPORTANT SAFETY INSTRUCTIONS

Your microwave oven is a cooking device and you should use as much care as you use with a stove or any other cooking device.

When using this electric appliance, basic safety precautions should be followed, including the following:

WARNING—To reduce the risk of burns, electric shock, fire, injury to persons or exposure to excessive microwave energy:

1. Read all instructions before using the appliance.
2. Read and follow the specific **"PRECAUTIONS TO AVOID POSSIBLE EXPOSURE TO EXCESSIVE MICROWAVE ENERGY,"** found at the bottom of this page.
3. This appliance must be grounded. Connect only to properly grounded outlet. See **"GROUNDING INSTRUCTIONS"** found on page 4.
4. Install or locate this appliance only in accordance with the installation instructions found on page 4.
5. Do not cover or block any openings on this appliance.
6. Do not store or use this appliance outdoors.
Do not use this product near water—for example, near a kitchen sink, in a wet basement, or near a swimming pool, and the like.
7. Use this appliance only for its intended use as described in this manual. **DO NOT** use corrosive chemicals, vapours, or non-food products in this appliance. This type of oven is specifically designed to heat or cook. It is not designed for industrial or laboratory use. The use of corrosive chemicals in heating or cleaning will damage the appliance and may result in radiation leaks.
8. When cleaning surfaces of door and oven that come together on closing the door, use only mild, non-abrasive soaps or detergents applied with a sponge or soft cloth.
9. Do not allow children to use this appliance, unless closely supervised by an adult.
10. Do not operate this appliance if it has a damaged cord or plug, if it is not working properly, or if it has been damaged or dropped.
11. Do not immerse cord or plug in water.
12. Keep cord away from heated surfaces.
13. Do not let cord hang over edge of a table or counter.
14. This appliance should be serviced only by qualified service personnel. Contact the nearest authorized servicentre for examination, repair or adjustment.
15. Some products such as whole eggs, narrow neck bottles and sealed containers—for example, closed glass jars - may explode and should not be heated in this oven.
16. To reduce the risk of fire in the oven cavity:
 - (a) Do not overcook food. Carefully attend appliance if paper, plastic, or other combustible materials are placed inside the oven to facilitate cooking.
 - (b) Remove wire twist-ties from paper or plastic bags before placing bag in oven.
 - (c) **If materials inside the oven should ignite, keep oven door closed, turn oven off, and disconnect the power cord, or shut off power at the fuse or circuit breaker panel.**
 - (d) Do not use the cavity for storage purposes.
Do not leave paper products, cooking utensils, or food in the cavity when not in use.

SAVE THESE INSTRUCTIONS

For proper use of your oven read remaining safety cautions and operating instructions.

PRECAUTIONS TO AVOID POSSIBLE EXPOSURE TO EXCESSIVE MICROWAVE ENERGY

- (a) **Do not attempt to operate this oven with the door open** since open-door operation can result in harmful exposure to microwave energy. It is important not to defeat or tamper with the safety interlocks.
- (b) **Do not place any object between the oven front face and the door,** or allow soil or cleaner residue to accumulate on sealing surfaces.
- (c) **Do not operate the oven if it is damaged.** It is particularly important that the oven door close properly and that there is no damage to the:
 - (1) door (bent)
 - (2) hinges and latches (broken or loosened)
 - (3) door seals and sealing surfaces.
- (d) **The oven should not be adjusted or repaired** by anyone except properly qualified service personnel.

INSTALLATION AND GROUNDING INSTRUCTIONS

Examine Your Oven

Unpack oven, remove all packing material, and examine the oven for any damage such as dents, broken door latches or cracks in the door. Notify dealer immediately if oven is damaged. **DO NOT** install if oven is damaged.

Remove Protective Plastic Film

If a plastic film has been wrapped around the oven to protect the painted finish from scratching during shipping, please remove this plastic film prior to using the oven. (However, all ovens do not have plastic film wrapping.)

Placement of Oven

1. Oven must be placed on a flat, stable surface. For proper operation, the oven must have sufficient air flow. Allow 7.6 cm of space on both sides of the oven and 2.5 cm of space on top of oven.
 - a. **DO NOT** block air vents. If they are blocked during operation, the oven may overheat. If the oven overheats, a thermal safety device will turn the oven off. The oven will remain inoperable until it has cooled.
 - b. **DO NOT** place oven near a hot damp surface such as a gas or electric range.
 - c. **DO NOT** operate oven when room humidity is too high.

Grounding Instructions

This appliance must be grounded. In the event of an electrical short circuit, grounding reduces the risk of electric shock by providing an escape wire for the electric current. This appliance is equipped with a cord having a grounding wire with a grounding plug. The plug must be plugged into an outlet that is properly installed and grounded.

WARNING—Improper use of the grounding plug can result in a risk of electric shock.

Consult a qualified electrician or service person if the grounding instructions are not completely understood, or if doubt exists as to whether the appliance is properly grounded.

If it is necessary to use an extension cord, use only a three wire extension cord that has a three blade grounding plug, and a three slot receptacle that will accept the plug on the appliance. The marked rating of the extension cord should be equal to or greater than the electrical rating of the appliance.

Wiring Requirements

1. The oven must be plugged into at least a 15 AMP 120 VOLT, 60 Hz GROUNDED OUTLET.
Where a standard two-prong outlet is encountered, it is the personal responsibility and obligation of the user to have it replaced with a properly grounded three-prong outlet (Fig. 1).

Fig. 1



2. The oven must be on a SEPARATE CIRCUIT. No other appliance should share the circuit with the microwave oven. If it does, the branch circuit fuse may blow, or the circuit breaker may trip or the food may cook slower than the times recommended in this manual.
3. The VOLTAGE used must be the same as specified on this microwave oven (120 V). Using a higher voltage is dangerous and may result in a fire or other accident causing oven damage. Using a lower voltage will cause slow heating. Panasonic is **NOT** responsible for damage resulting from the use of the oven with other than specified voltage.

Safety Precautions

General Use

1. **DO NOT** tamper with or make any adjustments or repairs to door, control panel housing, safety interlock switches or any other part of the oven. **Do NOT** remove outer panel from oven. Repairs should only be done by a qualified service person.
2. **DO NOT** operate the oven if empty. The microwave energy will reflect continuously throughout the oven causing overheating, if no food or water is present to absorb energy. This could damage the oven and result in a risk of fire.
3. If a fire occurs in the oven, press **STOP/RESET** Pad and **LEAVE DOOR CLOSED**.
Disconnect the power cord, or shut off power at the fuse or circuit breaker panel.
4. **DO NOT** dry clothes, newspapers or other materials in oven or use newspapers or paper bags for cooking. Fire could result.
5. **DO NOT** use recycled paper products unless the paper product is labelled as safe for microwave oven use. Recycled paper products may contain impurities which may cause sparks, and result in fires when used.
6. **DO NOT** hit or strike control panel. Damage to controls may occur.
7. **POT HOLDERS** should always be used when removing items from the oven. Heat is transferred from the **HOT** food to the heating container.
8. **DO NOT** store flammable materials next to, on top of, or in the oven. It could be a fire hazard.

Utensils

Use only containers and materials specified by their manufacturers to be for microwave use.

1. **METAL CONTAINERS** or dishes with metallic trims should not be used. Arcing may occur.
2. **METAL TWIST-TIES** may not be used in the microwave oven.
3. **DO NOT** use **SEALED JARS** or **NARROW NECK** bottles for cooking or reheating. They may shatter.
4. **DO NOT** use **CONVENTIONAL THERMOMETERS** in the microwave oven. They may cause arcing.
5. Remove **PLASTIC STORE WRAPS**, before heating in the oven.
6. When using foil, skewers, warming rack or utensils made of metal in the oven allow at least 2.5 cm of space between metal material and interior oven walls. If arcing (sparking) occurs remove metal material (skewers, etc.) and/or transfer to a nonmetallic container.

Food

1. It is better to **UNDERHEAT RATHER THAN OVERHEAT** foods. If food is underheated, it can always be returned to the oven for further heating. If food is overheated, nothing can be done. Always start with minimum heating times.
2. **SMALL QUANTITIES** of food or foods with **LOW MOISTURE** content can burn, dry out or catch on fire if heated too long.
3. Microwave popcorn which pops in its own package is available. Each brand of microwave popcorn recommends that their popcorn be used in microwave ovens listed at a specific wattage. For example: "Use in a microwave oven 600 watts or greater", or "Tested in microwaves of 450 to 1000 watts." Follow popcorn manufacturer's directions and use a brand suitable for at least a 650 watts microwave oven.
4. Do not attempt to deep fat fry in your microwave oven.
5. Do not boil eggs in their shell in a microwave oven. Pressure will build up and the eggs will explode.
6. Potatoes, apples, egg yolks, whole acorn squash and sausages are examples of foods with nonporous skins. These types of foods must be pierced before cooking, to prevent bursting.
7. Liquids can become "superheated" in a microwave, and when the container is moved in any way, the **superheated liquids can "explode" out of the container.** "Superheated" water is hotter than boiling water, **EVEN THOUGH IT DOES NOT APPEAR TO BUBBLE.** To reduce the possibility of this occurrence: **Always make sure that liquids are stirred vigorously** before heating to assure that the liquid is mixed with air. **NEVER HEAT LIQUIDS FOR AN EXCESSIVE LENGTH OF TIME.**
8. Do not use paper towels or cloths which contain a synthetic fiber woven into them, such as nylon. The synthetic fiber may cause the towel or cloth to ignite.
9. Do not use the oven for any reason other than the preparation of food.
10. Your oven is equipped with a protective device designed to turn the unit off in the event of overheating. The oven will automatically reset itself after it has cooled. (approx. 30~60 min.)

How Does The Microwave Work?

Microwaves are a form of high frequency radio waves similar to those used by a radio including AM; FM and CB. They are, however, much shorter than radio waves; approximately 13 cm long. Electricity is converted into microwave energy by the magnetron tube. From the magnetron tube, microwave energy is transmitted and absorbed.

Reflection

Microwaves are reflected by metal just as a ball is bounced off a wall. A combination of stationary (interior walls) and rotating antenna, located underneath the bottom shelf assure that the microwaves are well distributed within the oven cavity to produce even heating or cooking of foods.

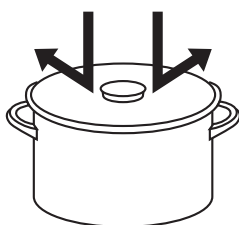

Transmission

Microwaves pass through some materials such as paper, glass and plastic much like sunlight shining through a window. Because these substances do not absorb or reflect the microwave energy, they are ideal materials for microwave oven heating containers.

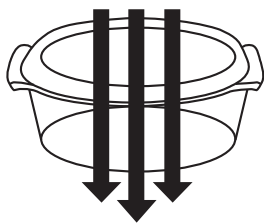

Absorption

During heating, microwaves will be absorbed by food. They penetrate to a depth of about 2 cm - 4 cm. Microwave energy excites the molecules in the food (especially water, fat and sugar molecules), and causes them to vibrate at a rate of 2,450,000,000 times per second. This vibration causes friction, and heat is produced just as you will feel heat produced if you vigorously rub your hands together. The internal heating of larger foods is done by conduction. The heat which is produced by friction travels by conduction to the center of the food. Foods also continue to heat by conduction during standing time. Because microwaves dissipate, much like sunlight as it reaches the Earth's surface, they are not stored in food.

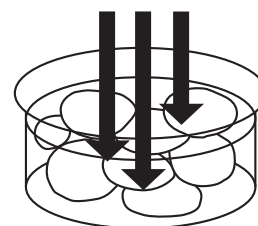

TV / Radio / Wireless Equipment Interference

1. Operation of the microwave oven may cause interference to your radio, TV, Wi-Fi, cordless telephone, baby monitor, blue tooth, or other wireless equipment.
2. When there is interference, it may be reduced or eliminated by taking the following measures:
 - a. Clean door and sealing surfaces of the oven. See Care of Your Microwave Oven found on page 17.)
 - b. Place the radio, TV, etc, away from the microwave oven as far as possible.
 - c. Use a properly installed antenna, to obtain stronger signal reception.

Outline Diagram

NE-1054F Control Panel

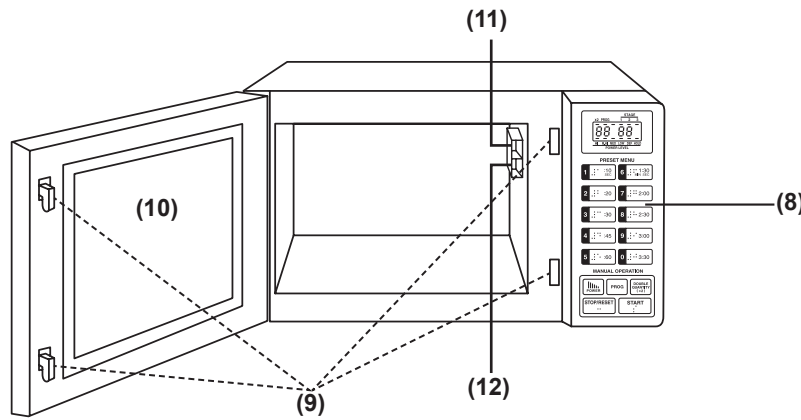
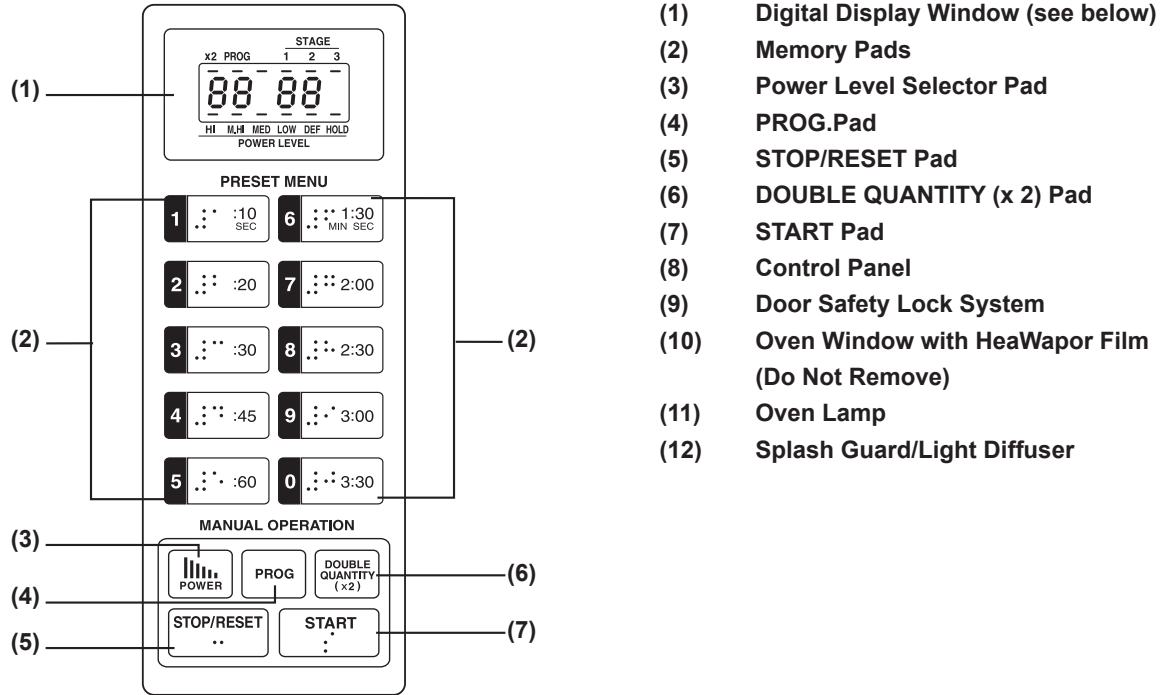

Digital Display Window Indicator Locations

- A – PROG. Indicator
- B – DOUBLE QUANTITY (x 2) Heating Indicator
- C – Memory Pad Number and Heating Time Display (min. sec.) – each indicator 0-9
- D – Stage Heating Indicator - 3 maximum

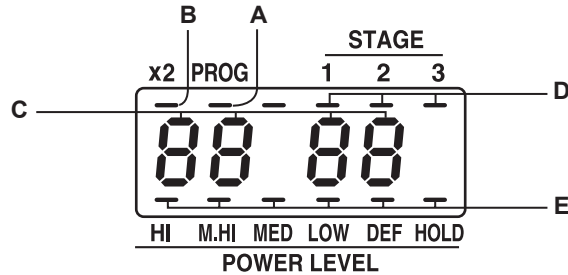

- E – Power Level Indicator
- HI (HIGH)
- M. HI (MEDIUM HIGH)
- MED (MEDIUM)
- LOW
- DEF (DEFROST)
- HOLD (Power OFF)

How to Operate

Before Operating

Make sure the oven is connected to a properly grounded electrical outlet.

When the door is closed, the Display Window is still blank. When the door is opened, the Display Window shows "0".

For the detail operation, see the page on each feature.

This oven is preset at the factory for the following:

1. Memory Pads are preset to High Power for the indicated heating times for single stage heating.

1 - 10 sec.	6 - 1 min. 30 sec.
2 - 20 sec.	7 - 2 min.
3 - 30 sec.	8 - 2 min. 30 sec.
4 - 45 sec.	9 - 3 min.
5 - 1 min.	0 - 3 min. 30 sec.

The **Double Quantity (x 2)** Pad is preset to automatically double the programmed time of each Memory Pad.

Example: press

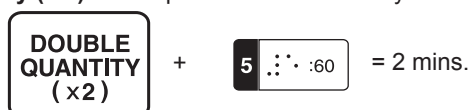

2. Program Unlock.

3. Cycle counter set to "0" on all pads.

To set the power level:

Select power level before programming the cooking time.

press



- 1 time.....HIGH
- 2 times.....MEDIUM HIGH
- 3 times.....MEDIUM
- 4 times.....LOW
- 5 times.....DEFROST
- 6 times.....HOLD

To set the cooking time:

You can set up to 99 minutes 99 seconds.

Example 1: To set 15 minutes 45 seconds



Example 2: To set 85 minutes 30 seconds



When you press the **START** Pad, the Display Window shows 1 hour 25 minutes instead of 85 minutes 30 seconds. When selected cooking time is over an hour, the Display Window shows hours and minutes, but the oven works for your setting time.

Display Window

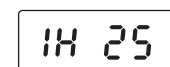
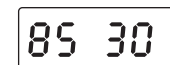
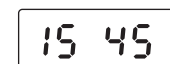

Display:

The Display Window will go blank (when the door is closed):

- at more than 1 minute interruption.
- at more than 1 minute after completion of heating and removing food.

The display will flash "0":

- continuously if food is not removed.

Oven Light:

Oven light will be turned on, when:

- you open the door.
- heating starts.

Oven light will be turned off, when:

- you close the door (no heating).
- heating finishes.

How to Operate





HEATING

Open the door and place food in the oven cavity. Close the door. **"0" must be showing in the Display Window.**

A. Manual Single Stage Heating:

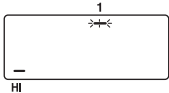
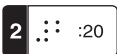
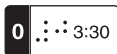
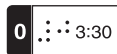
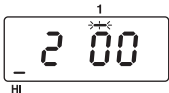
This feature gives the user maximum flexibility to set the oven to desired heating time and power level. Ideal for menus that require various heating requirements.

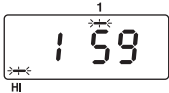





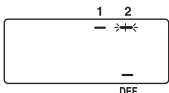

Example: To heat for 2 minutes at High Power

- | | | |
|---|---|--|
| <p>1. </p> | <ul style="list-style-type: none"> • Press the POWER Level Selector Pad one time. | <p>Display Window</p>  |
| <p>2.   </p> | <ul style="list-style-type: none"> • Press the Memory Pads 2, 0 and 0. |  |
| <p>3. </p> | <ul style="list-style-type: none"> • Press the START Pad. Heating will start. The time in the Display Window will count down. |  |
| <p>4. Beep tone will sound.</p> | <ul style="list-style-type: none"> • All heating will stop. When opening the door, the display will stop blinking. |  |

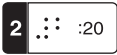
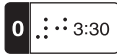
B. Manual 2 or 3 Stage Heating:

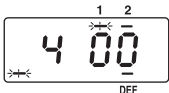
This feature allows you to set to begin heating at one power level then shift automatically to a different power level after the designated amount of heating time.

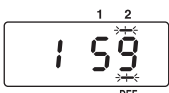
Example: To heat for 2 minutes at Defrost power for 2 stage heating

- | | | |
|---|--|--|
| <p>1. Follow steps 1 and 2 above.</p> | <ul style="list-style-type: none"> • Press the POWER Level Selector Pad 5 times. Indicator will change each time the pad is pressed. | <p>Display Window</p>  |
| <p>2. </p> | <ul style="list-style-type: none"> • Press the Memory Pads 2, 0 and 0. |  |
| <p>3.   </p> | <ul style="list-style-type: none"> • Press the START Pad. The total time for both stages will be displayed. The oven lamp will be turned on. Heating will start. |  |
| <p>4. </p> | <ul style="list-style-type: none"> • The time in the Display Window will count down. • When oven shifts to the next stage, a single beep tone will sound. |  |
| <p>5. Beep tone will sound.</p> | <ul style="list-style-type: none"> • All heating will stop. When opening the door, the display will stop blinking. |  |

NOTE:

For a 3 stage heating cycle, select a power level again and set the cooking time, between steps 3 and 4 above.

SPECIAL NOTE: For both single and 2 or 3 stage heating.

1. While heating, one touch on the **STOP/RESET** Pad stops the oven. You can restart by pressing the **START** Pad or a second touch on the **STOP/RESET** Pad will cancel the selected program.
2. One touch on the **STOP/RESET** Pad, before the heating cycle is started, will cancel the selected program.

How to Operate

C. Programmed Heating:

Example: 1 stage; Memory Pad 9 to heat for 3 minutes at HIGH Power



- Press the Memory Pad 9.
In Program Lock Mode oven will start without pressing **START** Pad. See page 14.

Display Window

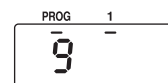

- Press the **START** Pad.
Heating will start.
The time in the Display Window will count down.

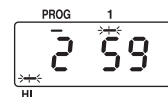

3. Beep tone will sound.

- All heating will stop.
When opening the door, the display will stop blinking.



Example: 2 stage; Memory Pad 3 (to heat for 3 minutes at HIGH and 2 minutes at DEFROST)

See page 12 to program Memory Pad.

See page 14 to activate Program Lock.



- Press the Memory Pad 3.
In Program Lock Mode oven will start without pressing **START** Pad. See page 14.

Display Window

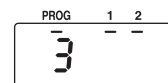

- Press the **START** Pad.
The total time for both stages will be displayed. The time in the Display Window will count down. Heating will start.
- When the oven shifts to the next stage, a single beep tone will sound.

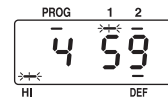

3. Beep tone will sound.

- All heating will stop.
When opening the door, the display will stop blinking.

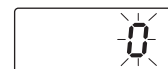

To Select Multiple Portion Heating:

The Double Quantity Pad (x 2) is factory set to automatically double the programmed time for multiple portion heating.

Example: Memory Pad 5

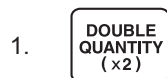

- Press the **DOUBLE QUANTITY (x 2)** Pad.

Display Window

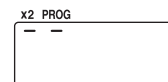

- Press the Memory Pad 5.
In Program Lock Mode oven will start without pressing **START** Pad. See page 14.

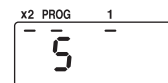

3. Follow steps 2-3 above.

How to Operate

Programming

— DO NOT OPEN THE DOOR —

The Display Window MUST be blank before programming can begin. If any indicator light is illuminated in the digital Display Window: Close the door, press **STOP/RESET** Pad and wait 1 minute until the Display Window goes blank.

Display Window



A. Programming Memory Pads for Single Stage Heating:

Example: To program 30 seconds at Medium Power for Memory Pad Number 5

1.



- Press the **PROG.** Pad.

NOTE:

- If no **PROG.** Indicator appeared in the Display Window, "Program Lock" should be cancelled. (See page 14.)
- Do not keep pressing **PROG.** Pad for more than 30 seconds, or a false failure code may result.

Display Window

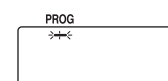

2.

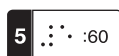

- Press Memory Pad 5.
The pad number and the previously selected time and power level will appear in the Display Window.

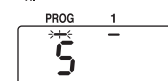
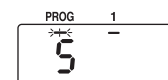

- The pad number and Stage Heating Indicator will appear in the Display Window again.

3.



- Press the **Power** Level Selector Pad 3 times. The Memory Pad display will go out.

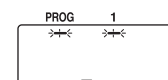

4.



- Press Memory Pads 3 and 0.

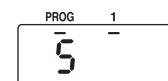

5.



- Press the **PROG.** Pad again.
You have completed programming the selected Memory Pad for single stage heating and double heating time for multiple portion heating automatically.

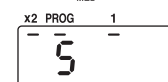
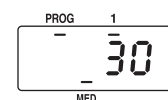

- 2 seconds later, the time and power level setting for single stage will appear in the Display Window.

- 2 seconds later, Double Quantity (x 2) Heating Indicator and then the double heating time will appear in the Display Window.

- 2 seconds later, the Display Window will go blank.



How to Operate

- NOTE:**
- Program the remaining Memory Pads as desired by repeating steps 1-5. You may insert up to 10 memory Programs.
 - When the **PROG.** indicator is blinking, the program can be cancelled and/or the Pad erased by pressing the **STOP/RESET** Pad.

B. Programming Memory Pads for 2 or 3 Stage Heating:

Example: To program for 2 minutes at DEFROST for 2 stage heating using Memory Pad Number 5

1. Complete Steps 1 to 4 on page 11.



- Press the **POWER** Level Selector Pad 5 times. DEF indicator light will light.

3.   

- Press the Memory Pads 2, 0 and 0.



- Press the **PROG.** Pad again. You have completed programming the Selected Memory Pad for 2 stage heating and double heating time for multiple portion heating automatically.

- 2 seconds later, the Display Window will show your setting program as step 5 on page 11.

- After all of your programming has been completed, the Display Window will go blank.

Display Window

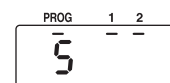
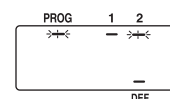

- NOTE:**
- Program the remaining pads as desired by repeating the steps above.
 - DO NOT OPEN THE OVEN DOOR during programming.
 - For a 3 stage heating cycle, select a further power level and set the desired heating time between steps 3 and 4 above.

How to Operate









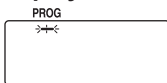

C. Programming the Double Quantity Pad - For multiple portion heating:

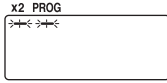
Your oven is factory set to automatically double the programmed time for multiple portion heating — this is the correct setting for heating multiple portions of most small foods items. No further programming of the time is necessary for these food items. The time required to heat multiple portions of some large platters and most bulk food loads is slightly less than double that of a single portion.

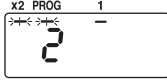
This model incorporates a Multiple Portion Heating Custom Program feature that allows you to customize the heating time and/or power level for multiple portions of your menu items.

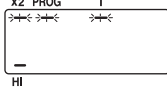
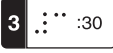
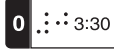
For example, if Memory Pad 3 is set for 6 minutes at DEFROST, 12 minutes at DEFROST is set for double quantity heating automatically. However, if your own tests have determined that the correct heating times required is less (only 10 minutes 30 seconds at DEFROST) for two portions, the "Multiple Portion Heating Custom Program" feature can be programmed for 10 minutes 30 seconds at DEFROST.

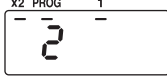
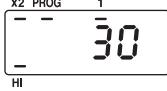
Example: To program 30 seconds at HIGH Power on Memory Pad Number 2

- | | | |
|---|--|---|
| <p>1. </p> | <ul style="list-style-type: none"> • Press the PROG. Pad. <p>NOTE:</p> <ul style="list-style-type: none"> • If no PROG. Indicator appears in the Display Window, "Program Lock" should be cancelled (see page 14). • Do not keep pressing PROG. Pad for more than 30 seconds, or a false failure code may result. | <p>Display Window</p>  |
| <p>2. </p> | <ul style="list-style-type: none"> • Press DOUBLE QUANTITY (x 2) Pad. |  |
| <p>3. </p> | <ul style="list-style-type: none"> • Press Memory Pad 2. <p>The pad number and the previously selected time and power level for multiple portion heating will appear in the Display Window.</p> |  |
| <p>4. </p> | <ul style="list-style-type: none"> • The pad number and Stage Heating Indicator will appear in the Display Window again. <ul style="list-style-type: none"> • Press the POWER Level Selector Pad once. The Memory Pad display will go out. |  |
| <p>5.  </p> | <ul style="list-style-type: none"> • Press the Memory Pads 3, 0. |  |
| <p>6. </p> | <ul style="list-style-type: none"> • Press the PROG. Pad again. <p>You have completed programming the selected Memory Pad for multiple portion heating.</p> <ul style="list-style-type: none"> • 2 seconds later, the setting for single stage heating will appear in the Display Window. • 2 seconds later, the Display Window will go blank. | 

 |

NOTE: • Program the remaining Memory Pad as desired by repeating steps 1-6 above. (You may insert up to 10 memory programs.)

DO NOT OPEN THE OVEN DOOR while programming.

• When the **PROG.** indicator is blinking, the program can be cancelled and/or the pad erased by pressing **STOP/RESET** Pad.

How to Operate

Other Features

A. To Activate Program Lock:

This procedure "Locks" the control panel Memory Pads into their programmed heating times and power levels. **DO NOT OPEN THE DOOR.** The Display Window must be blank before the Program Lock feature can be activated.

1.



- Press and hold in the **PROG.** Pad until the display shows "P" and "L". (for 6 seconds)
- Program Lock feature is now activated.

Display Window

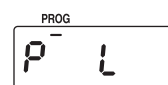
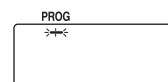

- NOTE:**
- Do not press **PROG.** Pad for longer than 30 seconds continuously, or false failure code may result.
 - In "Program Lock"
 - a. The oven is started by pressing the desired Memory pad. There is no need to press the **START** pad.
 - b. The interrupt feature is deactivated-opening the door cancels the remaining time on the program.
 - c. The oven cannot be programmed until the program lock feature is deactivated.

B. To Release Program Lock:

This procedure deactivates "Program Lock" and activates all other features. Oven reverts to a 2 touch operating mode (Memory Pad plus **START** Pad). **DO NOT OPEN THE DOOR.** The Display Window must be blank before the Release Program Lock feature can be activated.

1.



+



- Press the **STOP/RESET** Pad.
- While pressing this pad, press the **PROG.** Pad until the Display Window shows "P" (for 6 seconds).
- Program Lock Feature is deactivated, oven is now in "Program Unlock" mode.

Display Window

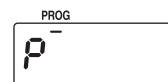
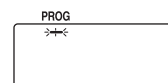

- NOTE:**
- Do not press **PROG.** Pad for longer than 30 seconds continuously, or a false failure code may result.
 - In "Program Unlock"
 - a. Repeat and interrupt features are operational.
 - b. Memory Pads can be programmed.
 - c. Tone loudness control is operational.

How to Operate

C. To Read Program List:

Allows you to review all currently programmed Pad Number, heating time and power level for each stage.

1. Open the door.



+



- While pressing the **STOP/RESET** Pad, press and hold in the **START** Pad. The Beep Tone setting will show in the Display Window.
Example: Stage Indicator 1: Beep tone is ON
Stage Indicator 2: Beep tone is OFF
- 2 seconds later, the Program Lock setting will show in the Display Window.
Program Lock : "P L"
Program Unlock: "P"

- Press Memory Pad you desired to read program.
Example: The Memory Pad Number 5. Display Window will display; Program Memory Pad Number 5, first stage heating time and power level currently programmed on Memory Pad.

2 seconds later, the same information will be displayed for the 2nd and 3rd stage heating.

- After all settings have been displayed, the Pad Number and the Stage Heating Indicator will appear in the Display Window again.

Display Window

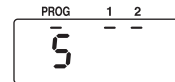
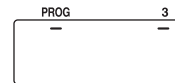
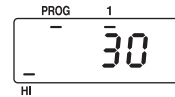
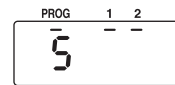
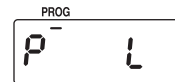
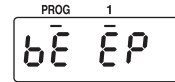

- NOTE:**
- If you want to go to another program, press the Memory Pad you desired to read program, while the information of Memory Pad is being displayed. .
 - If you want to show the Multiple Portion Heating (**x 2**) program, press the **DOUBLE QUANTITY** Pad before pressing the Memory Pad.

How to Operate

D. To Select Beep Tone Options:

The Beep Tone can be set, ON or OFF.

1. Open the door.



- Press the **PROG.** Pad.
The display will not change.



- Press the Memory Pad 0.
- Repeat pressing of 0 Pad. Select "OFF" of Beep Tone.
Stage Indicator 1 =ON
Stage Indicator 2 =OFF

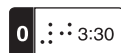

- Press the **PROG.** Pad again.
You have completed programming the beep tone.
- 2 seconds later, the Display Window will go blank.

Display Window

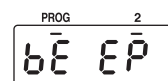
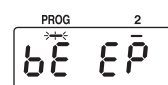
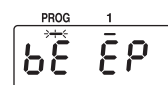

E. To Read the Cycle Counter:

The oven can display the total number of times the oven has been operated cumulatively.
Great for analyzing usage of the oven and traffic flow at the location.

1. Open the door.



- While pressing **STOP/RESET** Pad, press **POWER** Level Selector Pad. The display shows the total cumulative number of times the oven has been used.

Example:

- 9999 means, the oven has been used 999900 times.
- 0020 means the oven has been used 2000 times.
- If the total cumulative number of times less than 100 times, the display will not be changed.



Display Window

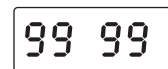

- 2 seconds later, "0" will reappear in the Display Window.

Self Diagnostics Failure Code Explanation

This oven monitors its operation and displays a Failure Code in the Display Window when a problem occurs.

What to do when a failure code appears:

CODE	CAUSE	WHAT TO DO
F01	* Overcooked food * Temperature of exhaust air too high.	* Press STOP/RESET Pad to stop beep. * Wait for oven to cool down and reset. * If a flame is present, do not open oven door. * If normal operation does not resume, call the service agent with information of failure code.
F33-34	* Defective sensor circuit	* Unplug the oven and wait more than 10 seconds before reconnecting.
F44	* When a pad was pressed for more than 30 seconds * Defective pad or control circuit	* If normal operation does not resume, call the service agent with the information of failure code.

NOTE: Above codes shown in Display Window do not indicate all the possible failures on the unit.

Care of Your Microwave Oven

1. Unplug the oven before cleaning.
2. Keep the inside of the oven clean. When food spatters or spilled liquids adhere to oven walls, wipe with a damp cloth. Mild detergent may be used if the oven gets very dirty. The use of harsh detergent or abrasives is not recommended. The air intake splash guard/light diffuser can be removed for cleaning by removing the center plugs from the two plastic rivets. The top is held by two tabs. Wash in warm dishwater and replace.
3. The outside oven surfaces should be cleaned with a damp cloth. To prevent damage to the operating parts inside the oven, water should not be allowed to seep into the ventilation openings.
4. If the Control Panel becomes wet, clean with a soft, dry cloth. Do not use harsh detergents or abrasives on Control Panel. When cleaning the Control Panel, leave oven door open to prevent oven from accidentally turning on. After cleaning, touch **STOP/RESET** Pad to clear Display Window.
5. If steam accumulates inside or around the outside of the oven door, wipe with a soft cloth. This may occur when the microwave oven is operated under high humidity conditions and in no way indicates malfunction of the unit.
6. Clean off grease and dust on bottom surfaces often. Use warm detergent solution.
7. Cleaning inside the oven outer panel and inside the oven base should be performed only by qualified service personnel after taking precautions to drain all stored voltage potential. The bottom is accessible by removing the center section of the base and the power and sensor control areas are within the outer wrap around housing. Avoid using liquids and cleaning solutions in these areas. Use a dry soft bristle brush or a cloth. Replace all parts-Do not connect the oven to the electricity supply if any parts are not reassembled.

Technical Specifications

	NE-1054F
Power Source	120 V, 60 Hz, single phase
Required Power	13.4A 1,500 W
Output*	1,000 W
Frequency	2,450 MHz
Outer Dimensions (W x H x D)	510 mm x 306 mm x 360 mm 20 ¹ / ₈ " x 12" x 14 ¹ / ₈ "
Cavity Dimensions (W x H x D)	330 mm x 205 mm x 330 mm 13" x 8 ¹ / ₈ " x 13"
Net Weight	Approximately 15.4 kg
Shipping Weight	Approximately 18 kg
Timer	99 min 99 sec (Digital) x 10 Memory Pads with Double Quantity (x2) Pad

*IEC Test Procedure
Specifications subject to change without notice

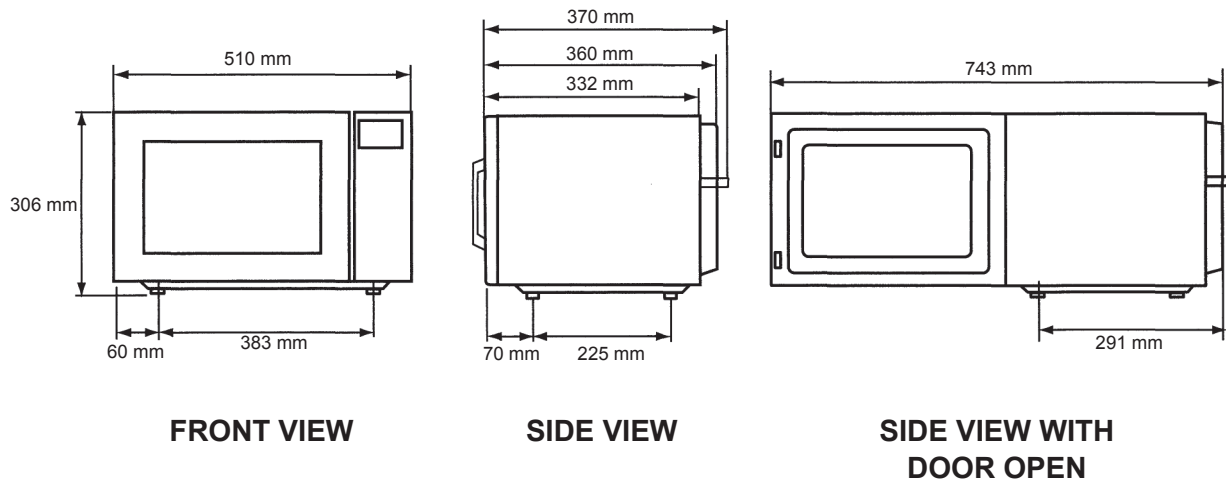

888, 898 Long Dong Ave, Pu Dong, Shanghai, China, 201203
Web Site: <http://panasonic.net>

TITAN STAINLESS

CUSTOM FOODSERVICE FABRICATION

502 Usher Street · Pageland, SC · 704-243-8717 · www.titan-stainless.com



WORKTABLE WITH BACKSPLASH AND UNDERSHELF

TITAN STAINLESS worktables are made using all-welded heavy gauge stainless steel construction. Assembly is not required; however, equipment can be disassembled for convenience. The backs of these tables are formed into a 5" tall x 2" thick backsplash with angled top; all other edges feature our standard nosing: 1-1/2" flange down with 1/2" return at 45°. Reinforcing channels are applied to the underside of the top and sealed with double-sided sound dampening tape. 1-5/8" diameter tubing is fitted into stainless steel leg sockets, which are welded to reinforcement below, preventing surface imperfections. Legs are removable, and furnished with adjustable stainless steel bullet feet. Full-length stainless steel undershelf is welded to the table legs. All welds are ground and polished to a smooth finish.



MODEL NUMBER SELECTION / INFORMATION

(Example #: 5SLUB-30)

Worktables are available in standard lengths from 2'-0" to 12'-0", in 1-foot increments. Standard widths (front-to-back) are available in 24", 30", and 36". Units over 6'-0" long will be furnished with an additional set of legs.

- See **AutoQuotes™** for full list of model numbers and pricing, along with all additional accessories
- Custom sizes and configurations are available upon request

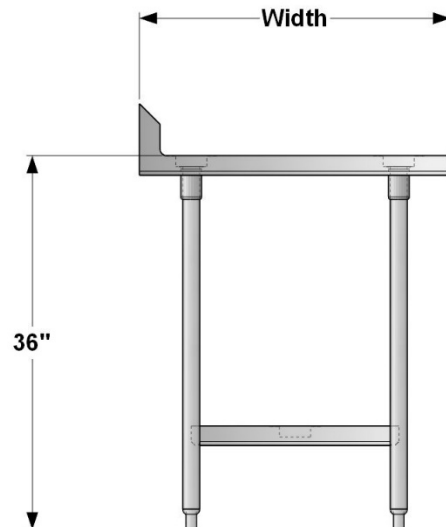
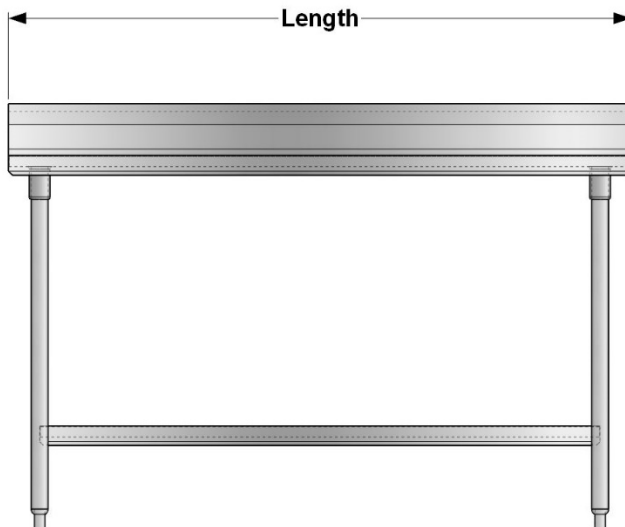



INSTALLATION & OPERATION MANUAL

V SERIES FOOD HOLDING, TRANSPORT, AND PROOFER CABINET

MODEL:

VP18 ML-138089



For additional information on Vulcan-Hart or to locate an authorized parts and service provider in your area, visit our website at www.vulcanhart.com

VULCAN-HART
DIVISION OF ITW FOOD EQUIPMENT GROUP, LLC
www.vulcanequipment.com

Vulcan ©2012 All Rights Reserved

3600 NORTH POINT BLVD.
BALTIMORE, MD 21222
F-41190 (11-12)

IMPORTANT FOR YOUR SAFETY

THIS MANUAL HAS BEEN PREPARED FOR PERSONNEL QUALIFIED TO INSTALL ELECTRICAL EQUIPMENT, WHO SHOULD PERFORM THE INITIAL FIELD START-UP AND ADJUSTMENTS OF THE EQUIPMENT COVERED BY THIS MANUAL.

FOR YOUR SAFETY

DO NOT STORE OR USE GASOLINE OR OTHER FLAMMABLE VAPORS OR LIQUIDS IN THE VICINITY OF THIS OR ANY OTHER APPLIANCE.

WARNING

Improper installation, adjustment, alteration, service, or maintenance can cause property damage, injury, or death.

Read the installation, operating and maintenance instructions thoroughly before installing or servicing equipment.

IN THE EVENT OF A POWER FAILURE,

DO NOT ATTEMPT TO OPERATE THIS DEVICE

TABLE OF CONTENTS

IMPORTANT FOR YOUR SAFETY	1
GENERAL	3
INTRODUCTION	3
INSTALLATION	3
ELECTRICAL REQUIREMENTS	4
OPERATION	5
CONTROLS	5
PROOFING OPERATING INSTRUCTIONS	6
DOUGH PREPARATION	7
PROOFING GUIDELINE	7
PROOFING SHUTDOWN	7
HOLDING OPERATING INSTRUCTIONS	8
HOLDING SHUTDOWN	8
CLEANING	9
DAILY CLEANING	9
HEAVY-DUTY CLEANING	9
STAINLESS STEEL CARE	9
CLEANING	9
PREVENTIVE CARE	9
PRESERVING & RESTORING	9
HEAT TINT	10
MAINTENANCE	10
LOCKOUT / TAGOUT PROCEDURE	10
TROUBLESHOOTING	11
SERVICE & PARTS INFORMATION	11
SPECIFICATIONS	12
WIRING DIAGRAM	13
WARRANTY	14

GENERAL

INTRODUCTION

Vulcan-Hart Holding & Transport and Proofing Cabinets are produced with quality workmanship and material. Proper installation, usage, and maintenance of your cabinet will result in many years of satisfactory performance.

It is suggested that you thoroughly read this entire manual and carefully follow all of the instructions provided.

INSTALLATION

Before installing, verify that the electrical service agrees with the specifications on the rating plate located on the lower back corner of the cabinet. (Fig. 4) If the supply and equipment requirements do not agree, do not proceed with unpacking and installation. Contact your Vulcan-Hart Customer Service Department immediately.

UNPACKING:

The Cabinet was inspected before leaving the factory. The transportation company assumes full responsibility for safe delivery upon acceptance of the shipment. Immediately after unpacking, check for possible shipping damage to the cabinet.

If the cabinet is found to be damaged, save the packaging material and contact the carrier within 15 days of delivery.

Carefully unpack and place in a work accessible area as near the installation position as possible.

1. Open the door and carefully remove any packaging materials. Remove 20 Tray Slides and 2 Water Pans. (10"x12"x2½")
2. Peel off all vinyl protection film.
3. Install desired number of Tray Slides. Make sure the hook on the end of the tray slide is up. (Fig. 1)



(Fig. 1)

4. Insert one (1) Water Pan in opening at the bottom of the cabinet and insert one (1) Water Pan through slides underneath the cabinet. (Fig. 2)



(Fig. 2)

CLEANING:

The cabinet should be thoroughly cleaned prior to putting into service.

Use a mild soap and water solution to clean the interior of the unit. Never use harsh chemicals or abrasive pads to clean the unit. See cleaning instructions in this manual.

LOCATION:

For efficient cabinet operation, choose a location that will provide easy loading and unloading without interfering with the final assembly of food orders.

The installation location must allow adequate clearances for servicing and proper operation. (Fig. 3)

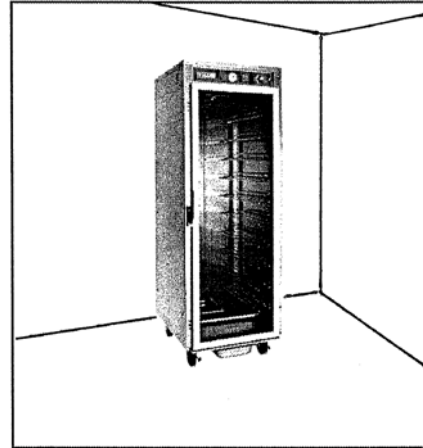

(Fig. 3)

When cabinet is in position, secure the brakes on the front two wheels. These brakes should always be locked when the cabinet is in use.

ELECTRICAL REQUIREMENTS

ELECTRICAL CODES & STANDARDS:

The cabinet must be installed in accordance with:

In the United States of America:

1. State and Local Codes.
2. National Electrical Code, ANSI/NFPA-70 (latest edition.) Copies may be obtained from: The National Fire Protection Association, 1 Batterymarch Park, Quincy, MA 02269.
1-617-770-3000 www.nfpa.org

In Canada:

1. Local Codes.
2. Canadian Electrical Code, CSA C22.1 (latest edition.) Copies may be obtained from: The Canadian Standard Association.
www.csa.ca

ELECTRICAL CONNECTIONS:

The cabinet is factory wired for either 110/120 volt or 208/240 volt, single phase operation. All 110/120 volt cabinets are equipped with a 8 foot cord and NEMA 5-20 plug as standard equipment. All 208/240 volt cabinets are equipped with an 8 foot cord and NEMA 6-15 plug. Refer to wiring diagram in the back of this manual.

The cord and plug supplied is a suitable durable cord with a molded three-prong plug, and is provided with a proper strain relief.

⚠ WARNING All cabinets are equipped with a three-prong plug. It is imperative that this plug must be connected into a properly grounded three-prong receptacle. If the receptacle is not the proper grounding type, contact an

electrician. **Do not remove the grounding prong from this plug.**

Verify that the power source matches the Serial Data Plate located on the lower back corner of the cabinet and the plug configuration before the connection is made. (Fig.4)

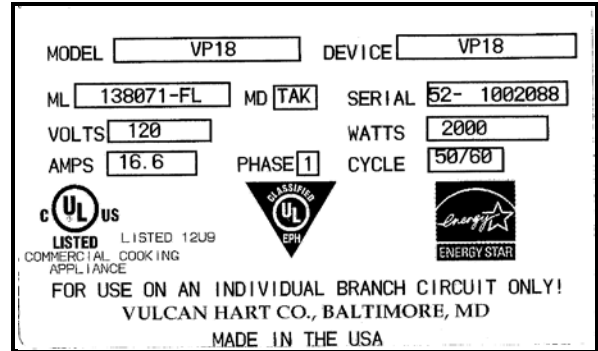

(Fig. 4)

OPERATION

CONTROLS

⚠ WARNING The Cabinet and its parts are hot. Be very careful when operating, cleaning, or servicing the cabinet.

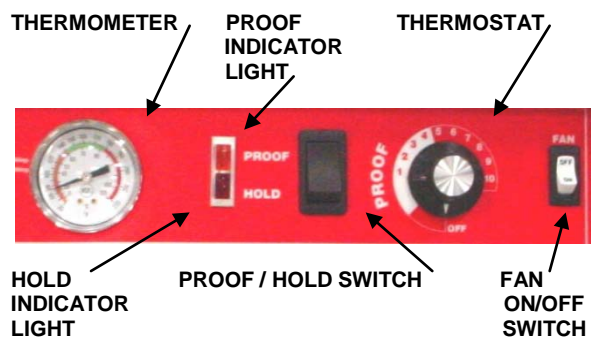

Thermometer:

The Thermometer indicates the interior temperature of the cabinet.

Proof Indicator Light:

The Proof Indicator Light indicates power is supplied to the cabinet and the cabinet is in Proofing Mode.

Thermostat:

The Thermostat turns power on to the heating elements. If “Proofing mode” is desired, the thermostat should be set in the white “Proof” area (1 through 4.) If “Holding mode” is desired, the thermostat should be set in the red area (5 through 10.) (Fig. 5)

Hold Indicator Light:

The Hold Indicator Light indicates power is supplied to the cabinet and the cabinet is in Holding Mode.

Proof / Hold Switch:

Flip the switch upward for Proofing mode or flip the switch downward for Holding mode.

Fan On/Off Switch:

The Fan On/Off Switch turns the fan on or off only.

Mode	Thermostat Setting	Approximate Temperature
PROOF	1	100°F (37°C)
	2	110°F (43°C)
	3	120°F (49°C)
	4	130°F (54°C)
HOLD	5	140°F (60°C)
	6	150°F (66°C)
	7	160°F (71°C)
	8	170°F (77°C)
	9	180°F (82°C)
	10	190°F (88°C)

(Fig.5)

PROOFING OPERATING INSTRUCTIONS

⚠ WARNING Always disconnect power cord prior to adding water to the water pan inside the cabinet. Do not over fill water pan with water.

1. Fill Water Pan at the bottom of cabinet with a maximum of approx. 2 liters, or one-half full, of clean warm water. **Never fill water pan more than one-half full.** *If proofing for a long period of time, check the water pan occasionally and refill if needed.*
2. Plug in power cord to appropriate power source.
3. Switch Proof/Hold Switch upward to Proof position. The Proof Indicator Light should be lit.
4. Turn the Thermostat to “2” or to desired setting. See Fig. 5.

Ideal proofing conditions consist of a temperature of 100° F and 80% to 90% humidity. Proofing times will vary depending on the handling and types of dough products. Sugar and yeast must be able to react properly. This process takes a certain amount of time and cannot be altered by adjusting the settings.

5. Turn Fan Switch to On position. The use of the fan is optional. Use of the fan keeps the temperature even throughout the cabinet.

6. Preheat approximately 15 to 30 minutes to reach desired temperature and humidity.

⚠ WARNING The Cabinet and its parts are hot. Be very careful when operating, cleaning, or servicing the cabinet.

At the proper setting, your proofer door will have a light haze of moisture on it. If water beads up and runs down the door, the setting or amount of water in the water pan is too high. You may need to adjust according to atmospheric conditions.

7. Place pans with prepared dough inside cabinet. It is recommended that dough is completely thawed and at room temperature before placing in the proofer. See *dough preparation (page 7) for suggested guidelines.*
8. Close cabinet door and monitor until dough is ready. Proofing time is approximately 15 to 45 minutes.

Note: Proofing time will vary depending on the different dough products. Always monitor your products for desired results. The door should not be opened unnecessarily to conserve the heat and humidity inside the cabinet.

A Water Pan is located underneath the cabinet to collect excess condensation. Make sure to periodically check and empty this pan.

DOUGH PREPARATION

If Dough is Frozen:

- Grease pan. Place frozen dough on pan and brush tops of dough with oil, cover dough lightly with a film wrap, and refrigerate until dough thaws and reaches 40°F (4 to 6 hours or overnight.)

It is important during thawing that the tops of the dough product must not “crust” or dry out. This can be prevented by oiling the tops and lightly covering the dough with a film wrap. This film wrap must not be tucked in at the sides – it should merely lie on top of the greased dough. **Note: Always remove this film wrap before proofing.**

- Remove dough from refrigerator and allow the dough to reach room temperature.

Hint: You may want to place the dough on a greased room temperature pan. This helps shorten the proofing time. Placing cold pans in the proofer brings the temperature down inside the cabinet and lengthens the proofing time.



PROOFING GUIDELINE

	# Of Buns	Dough Temp.	Approx. Proof Time	Cabinet Temp.
FRESH PREPARED DOUGH	1 to 10	Room Temp.	30 min.	90-95°F
	10 to 20	Room Temp.	33 min.	90-95°F
	20 to 30	Room Temp.	35 min.	90-95°F
	30 to 40	Room Temp.	38 min.	90-95°F
	40 to 50	Room Temp.	40 min.	90-95°F
REFRIGERATED DOUGH	1 to 10	30° - 45°F.	35 min.	90-95°F
	10 to 20	30° - 45°F.	39 min.	90-95°F
	20 to 30	30° - 45°F.	43 min.	90-95°F
	30 to 40	30° - 45°F.	46 min.	90-95°F
	40 to 50	30° - 45°F.	50 min.	90-95°F

PROOFING SHUTDOWN

⚠ WARNING The Cabinet and its parts are hot. Be very careful when operating, cleaning, or servicing the cabinet.

When the use of the proofing cycle is completed:

- Turn the thermostat to the Off position.
- Keep the fan switch in the On position. This helps remove the excess humidity.
- Open the door slightly to let out the humidity and to prevent mold.
- Allow cabinet to cool down completely.
- Unplug power cord.
- Empty and clean both water pans.
- Clean cabinet according to instructions in this manual.

HOLDING OPERATING INSTRUCTIONS

⚠ WARNING The Cabinet and its parts are hot. Be very careful when operating, cleaning, or servicing the cabinet.

Once the cabinet has been connected to the appropriate power source, the cabinet is ready for operation.

1. Switch Proof/Hold Switch downward to the Hold position. The Hold Indicator Light should be lit.
2. Turn the Thermostat to desired setting between 5 and 10. See Fig. 5.

3. Switch the Fan switch to On if forced air holding is desired. The use of the fan is optional. Use of the fan keeps the temperature even throughout the cabinet.
4. Wait approximately 25 minutes for the cabinet to preheat.
5. Load Hot food pans with hot, cooked food into cabinet.
6. When removing items, start at the bottom and work up. This will keep food hotter and eliminate spillage onto lower items.

This cabinet is not intended to reheat food. Food must be cooked and at a safe serving temperature prior to being placed in the cabinet.

The operator should always monitor the food product to insure that it remains at a proper temperature.

HOLDING SHUTDOWN

⚠ WARNING The Cabinet and its parts are hot. Be very careful when operating, cleaning, or servicing the cabinet.

When the use of the holding cycle is completed:

1. Turn the thermostat to the Off position.
2. Keep the fan switch in the On position. This helps remove the

excess humidity from the food product.

3. Allow cabinet to cool down completely.
4. Unplug power cord.
5. Clean cabinet according to instructions in this manual.

CLEANING

▲ WARNING Always *unplug electrical power supply* before cleaning.

▲ WARNING The Cabinet and its parts are *HOT*. Be very careful when operating, cleaning, or servicing the cabinet.

DAILY CLEANING:

1. Unplug electrical power supply.
2. Allow warmer to cool before cleaning.
3. Clean the interior of the cabinet with a mild soap and water. *Never use harsh chemicals or abrasive pads to clean the cabinet.*
4. Rinse and dry with a soft dry cloth.
5. Clean the exterior of the cabinet with a clean damp cloth.

HEAVY-DUTY CLEANING:

For heavy-duty cleaning, use warm water, a degreaser, and a plastic, stainless steel, or Scotch-Brite pad. Never rub in a circular motion -- rub gently in the direction of the steel grain. Always rinse thoroughly.

STAINLESS STEEL CARE

CLEANING:

Stainless Steel contains 70 – 80% iron, which will rust if not properly maintained. Stainless Steel also contains 12 – 30% chromium, which forms an invisible

passive, protective film that shields against corrosion.

If the protective film remains intact, the stainless steel will remain intact. However, if the film is damaged, the stainless steel can break down and rust.

PREVENTIVE CARE:

To prevent stainless steel break-down, follow these steps:

1. **Never use any metal tools, scrapers, files, wire brushes, or scouring pads** (*except for stainless steel scouring pads,*) which will mar the surface.
2. **Never use steel wool** – which will leave behind particles that will rust.
3. **Never use acid-based or chloride containing cleaning solutions** – which will break down the protective film.
4. **Never rub in a circular motion.** Always rub gently in the direction of the steel grain.
5. **Never leave any food products or salt on the surface.** Many foods are acidic. Salt contains chloride.

PRESERVING & RESTORING:

Special stainless steel polishing cleaners can preserve and restore the protective film.

Preserve the life of stainless steel with a regular application of a high-quality stainless steel polishing cleaner, as a final step to daily cleaning.

If signs of breakdown appear, restore the stainless steel surface. First, thoroughly clean, rinse, and dry the surface. Then, on a daily basis, apply a high-quality stainless steel polish according to manufacturer's instructions.

HEAT TINT:

Darkened areas, called "heat tint," may appear on stainless steel exposed to excessive heat. Excessive heat causes the protective film to thicken. This is unsightly, but is not a sign of permanent damage.

To remove heat tint, follow the routine cleaning procedure. Stubborn heat tint will require heavy-duty cleaning.

To reduce heat tint, limit the exposure of equipment to excessive heat.

MAINTENANCE

▲ WARNING Unplug electrical power supply before servicing the cabinet.

▲ WARNING The Cabinet and its parts are *HOT*. Be very careful when operating, cleaning, or servicing the cabinet.

For Service, contact the Vulcan-Hart offices listed in this manual.

LOCKOUT / TAGOUT PROCEDURE



▲ WARNING Always perform the Lockout / Tagout Procedure before removing any sheet metal panels or attempting to service this equipment.

The Lockout / Tagout Procedure is used to protect personnel working on an electrical appliance. Before performing any type of maintenance or service on an electrically operated appliance, follow these steps:

1. In electrical box, place unit's circuit breaker into OFF position.
2. Place a lock or other device on electrical box cover to prevent someone from placing circuit breaker ON.
3. Place a tag on electrical box cover to indicate that unit has been disconnected for service and power should not be restored until tag is removed by maintenance personnel.
4. Disconnect unit power cord from electrical outlet.
5. Place a tag on cord to indicate that unit has been disconnected for service and power should not be restored until tag is removed by maintenance personnel.

TROUBLESHOOTING

SYMPTOMS	POSSIBLE CAUSES	REMEDY
Cabinet not operating	Cabinet not connected to power source.	Connect cabinet to power source.
	No power.	Check circuit breaker
		Check GFCI
GFCI or Ground Fault Circuit Indicator tripped	Moisture problem.	Dry moisture problem.
	Shorted element	Contact Authorized Service Provider.
	Pinched/damaged wire.	Contact Authorized Service Provider.
	Damaged power cord.	Contact Authorized Service Provider.
Cabinet is connected to power source, switch is ON, circuit breaker is ON, but cabinet is not heating.	Defective: element, thermometer, thermostat, etc.	Contact Authorized Service Provider.
Proof/Hold Indicator Light not lit.	Light faulty	Contact Authorized Service Provider.
Cabinet does not heat properly	Door not shut properly or needs adjustment	Check door seal and Contact Authorized Service Provider.
	Defective: element, thermometer, thermostat, thermostat requires adjustment	Contact Authorized Service Provider.
Fan not operating	ON/OFF switch not ON	Turn ON/OFF switch ON
	Defective fan.	Contact Authorized Service Provider.
Excessive Humidity	Too much water in Water Pan	Adjust Water
	Drain hole clogged for Drip Pan underneath Cabinet	Clean drainage hole and check Drip Pan

SERVICE & PARTS INFORMATION

To obtain Service and Parts information concerning this model, contact Vulcan-Hart Service Department at the address listed on the front cover of this manual, or refer to our website: www.vulcanhart.com for a complete listing of Authorized Service and Parts depots.

Customer Service	1-800-814-2028
Technical Service	1-800-814-2028
Service Parts	1-800-814-2028

When calling for service, have the model number and serial number available.

SPECIFICATIONS

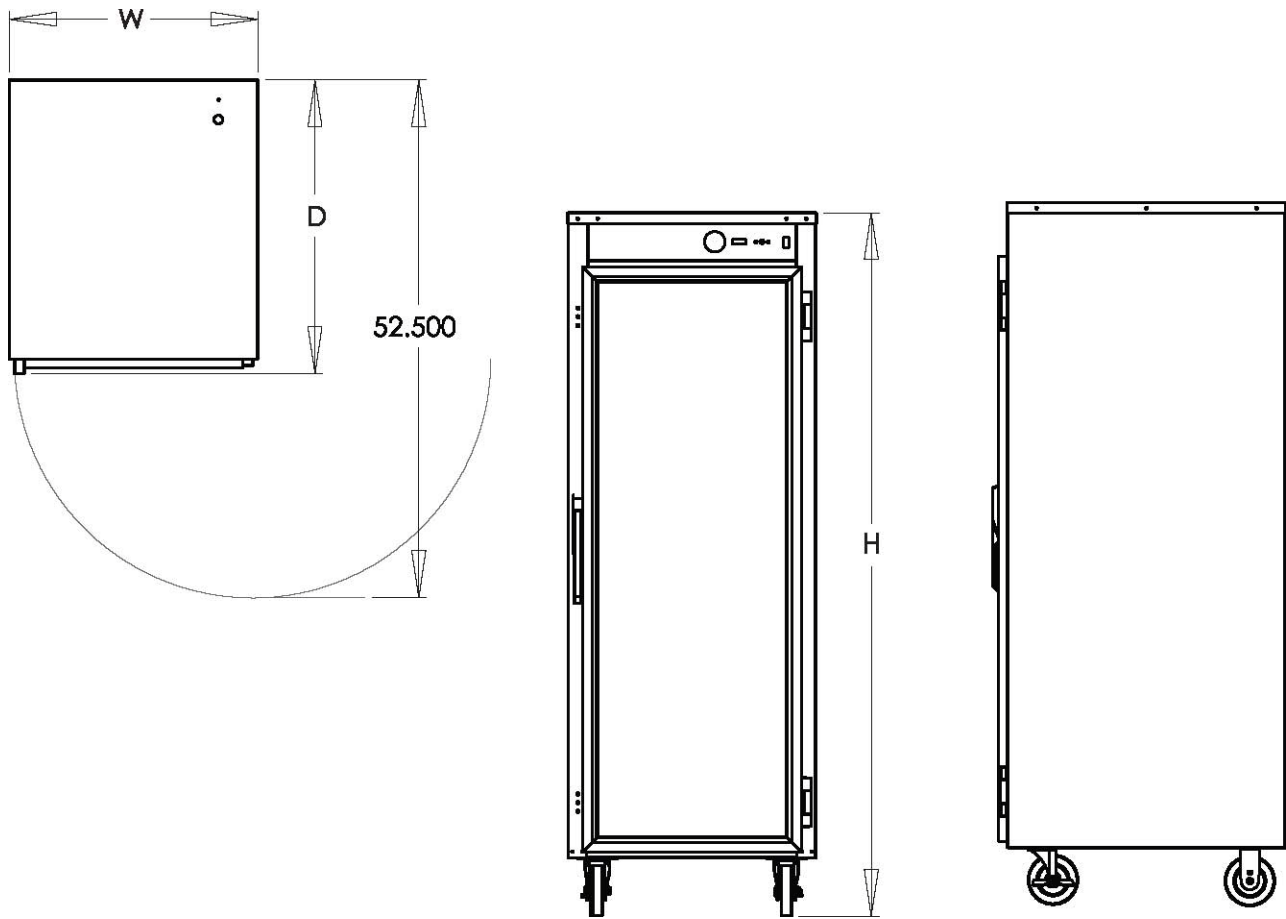

CAPACITY		DIMENSIONS	ELECTRICAL			SHIPPING WEIGHT	
18"X26" PANS	12"X20" PANS		VOLTS	WATTS	AMPS	LBS.	KG.
18	36	EXTERIOR 25 ¹ / ₄ " W x 30 ³ / ₄ " D x 71" H	120	2,000	16.7	220	100

Vulcan reserves the right to change materials and specifications without notice.

WIRING DIAGRAM

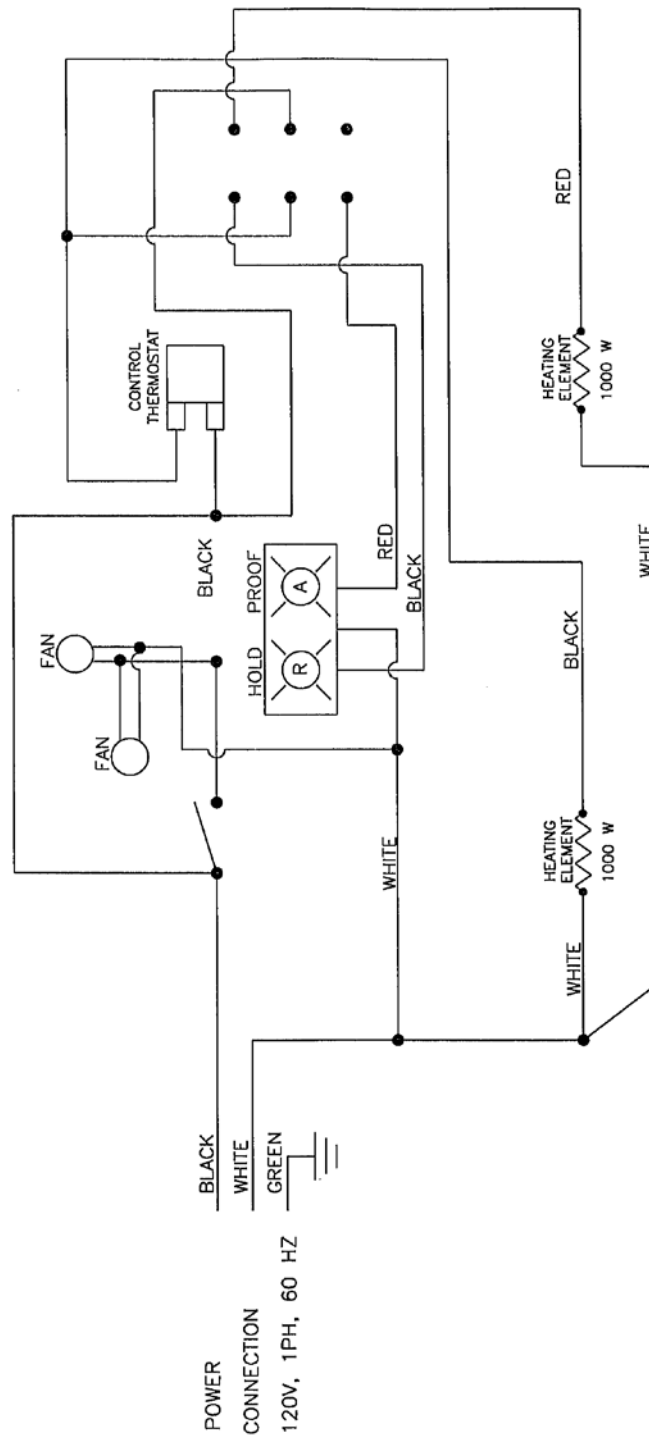



LIMITED ORIGINAL COMMERCIAL EQUIPMENT WARRANTY

Vulcan warrants its new product(s) (the "Products") to be free from defects in material and workmanship for a period of one (1) year from the date of original installation.

Wolf is affiliated with Vulcan and thus Wolf products carry the same warranty as the Products.

This warranty is subject to the following conditions and limitations:

1. This warranty is limited to Product(s) sold by Vulcan to the original user in the continental United States and Canada.
2. Original installation must occur within eighteen (18) months of the date of manufacture, and written proof of the installation date must be provided to Vulcan. The Products must be located at the original installation location.
3. Vulcan's sole liability shall be at Vulcan's option, for Vulcan to repair or replace any Product(s) found to be defective.
4. Vulcan will bear normal labor charges incurred in the repair or replacement of a warranted Product within 50 miles (80 kilometers) of an authorized service agency. Time and travel charges in excess of 50 miles (80 kilometers) will be the responsibility of the Buyer requesting the service.
5. This warranty does not apply to any Product(s) which have not been used, maintained or installed in accordance with the directions published in the appropriate installation and operation manuals. Vulcan will bear no responsibility or liability for any Product(s) which have been mishandled, abused, misapplied, misused, subjected to harsh chemical action or poor water quality, modified by unauthorized personnel, damaged by flood, fire or other acts of nature, or which have altered or missing serial numbers.
6. Vulcan does not recommend or authorize the use of any Product(s) in a non-commercial application, including but not limited to residential use. The use or installation of Product(s) in non-commercial applications renders all warranties, expressed or implied, including the warranties of MERCHANTABILITY and FITNESS FOR A PARTICULAR PURPOSE, null and void, including any responsibility for damage, costs and legal actions resulting from the use or installation of Product(s) in any non-commercial setting.
7. Adjustments such as calibrations, leveling, tightening of fasteners or utility connections normally associated with original installation are the responsibility of the installer and not that of Vulcan.
8. Exceptions to the one-year part warranty period are as listed:
 - Fryer equipment is supplied with limited fry tank warranty based on model. (See separate warranty statement.)
 - Steam equipment supplied with ScaleBlocker® water filtration system. (See separate warranty statement.)
 - Pressure steam boilers-5 years prorated. (Boilers not properly maintained will not be considered for prorated warranty.)
 - Rubber seals, light bulbs and gaskets-90 days from installation.
 - Heating elements on drawer warmers, cook & hold ovens and holding & transport cabinets have a lifetime warranty.
 - Drawer rollers in drawer and chip warmers have a lifetime warranty.
 - Labor, travel and mileage will be covered during the first year only.
 - Heating elements on models 1024, 1036 and 1048-90 days from installation.
 - Refrigeration compressor part-5 years from the date of installation, the date of end user invoice or the date of dealer invoice, whichever is later, but in any case not to exceed 18 months from dealer invoice date.
9. Original purchased replacement parts manufactured by Vulcan will be warranted for 90 days from the parts invoice date. Exceptions are stainless steel fry tanks, refrigeration appliance compressors and pressure steam boilers which will be warranted as stated in item 8. This warranty is for parts cost only, and does not include freight or labor charges.
10. This states the exclusive remedy against Vulcan relating to the Product(s), whether in contract or in tort or under any other legal theory, and whether arising out of warranties, representations, instructions, installations or defects from any cause. Vulcan shall not be liable, under any legal theory, for loss of use, revenue or profit, or for substitute use or performance, or for incidental, indirect, punitive or special or consequential damages or for any other loss of cost of similar type. In no event shall Vulcan's liability exceed the purchase price of the Products.
11. THIS WARRANTY AND THE LIABILITIES SET FORTH HEREIN ARE EXCLUSIVE AND IN LIEU OF ALL OF THEIR LIABILITIES AND WARRANTIES, EXPRESSED OR IMPLIED, INCLUDING BUT NOT LIMITED TO, IMPLIED WARRANTIES OR MERCHANTABILITY AND FITNESS FOR PARTICULAR PURPOSE AND CONSTITUTES THE ONLY WARRANTY OF VULCAN WITH RESPECT TO THE PRODUCT(S).



OWNER'S MANUAL



Instructions for the installation, operation and maintenance of all Centerline™ by Traulsen: Reach-In Refrigerators & Freezers*

*Please Note: This manual is intended for use with the above referenced equipment manufactured after June 01, 2022.

4401 Blue Mound Road Fort Worth, Texas 76106 (USA)

Phone: 800.825.8220 | Service Fax: 817.740.6757 | E-mail: service@traulsen.com | Website: centerlinefoodequipment.com

Hours of Operation: Monday - Friday 7:30 a.m. - 4:30 p.m. (CST)

TABLE OF CONTENTS

I. THE SERIAL TAG	Page 1	V. CARE AND MAINTENANCE	Page 5
a) Serial Tag & Location	Page 1	a) Cleaning the Condenser	Page 5
b) Reading The Serial Tag	Page 1	b) Hinge Replacement	Page 6
II. RECEIPT INSPECTION	Page 2	c) Replacing the Gaskets	Page 6
III. INSTALLATION	Page 2	d) Cleaning the Exterior	Page 6
a) Location	Page 2	e) Cleaning the Interior	Page 6
b) Packaging	Page 2	f) Adjusting the Shelves	Page 6
c) Installing Legs or Casters	Page 2	VI. CONTROL BASICS	Page 7
d) Installing Drain Pan	Page 3	a) Information Menu	Page 7
e) Shelves	Page 3	b) Adjusting Cabinet Setpoint	Page 7
f) Removing Doors and Hardware	Page 3	c) Initiating a Defrost	Page 7
g) Door Removal for Half Door Units	Page 4	d) Configuration Parameters	Page 8
h) Cord & Plug	Page 4	e) Technical Data	Page 8
i) Power Supply	Page 4	f) Components and Wiring Diagram	Page 13
j) Wiring Diagram	Page 4	VII. TROUBLESHOOTING GUIDE	Page 14
k) Installing Optional Interior Kits	Page 4	VIII. SERVICE/WARRANTY INFORMATION	Page 15
IV. OPERATION	Page 5	a) Service Information	Page 15
a) Operation Display Indicators	Page 5	b) Spare Parts Information	Page 15
b) Refrigerators	Page 5	c) Warranty Registration	Page 15
c) Freezers	Page 5	d) Warranty Statement	Page 16
d) Light Switches	Page 5		

I. THE SERIAL TAG





I. a - SERIAL TAG & LOCATION

The serial tag is a permanently affixed label on which is recorded vital electrical and refrigeration data about your Centerline product, as well as the model and serial number. This tag is located in upper right interior compartment on all reach-in refrigerator and freezer models.

I. b - READING THE SERIAL TAG

- **Model** = The model # of your Traulsen unit
- **(S/N) Serial Number** = The permanent ID# of your Traulsen unit
- **Refrigerant SYS1** = System 1 Refrigerant type used and refrigerant charge
- **Design Pressure** = System 1 High and Low Pressure
- **Refrigerant SYS2** = System 2 Refrigerant type used and refrigerant charge
- **Design Pressure** = System 2 High and Low Pressure
- **Volts** = Voltage
- **Hz** = Cycle
- **PH** = Phase
- **Total Current** = Maximum amp draw
- **Min Circuit Amps** = Minimum circuit ampacity
- **Lights** = Light wattage
- **Agency Labels** = Designates agency listings
- **Components** = Component Ratings



MODEL: MODELO: MODELE:	CLBM-23R-FS			
S/N:	T99999A99			
REFRIGERANT / REFRIGERANTE / RÉFRIGÉRANT				
SYS1 (REFM):	R-450A	14.00 oz	396.89 g	
Hi Press. (PRESH):	330 psi	2.28 MPa	(2,28 MPa)	
Lo Press. (PRESL):	150 psi	1.03 MPa	(1,03 MPa)	
SYS2 (REFA):				
Hi Press. (PRESH):				
Lo Press. (PRESL):				
Input Power (ELIN) - FOR INDOOR USE ONLY				
	115 V	60 Hz	~	3.8 A (3,80 A)
				
Intertek 5017388		Intertek 5017388		
CERTIFIED TO UL 508, 508A, 508B, 508C, 508D, 508E, 508F, 508G, 508H, 508I, 508J, 508K, 508L, 508M, 508N, 508O, 508P, 508Q, 508R, 508S, 508T, 508U, 508V, 508W, 508X, 508Y, 508Z		CONFORMES TO NBT / ANSI STD 7		
Device/Part Number:	Device/Part Notes:			
CLBM-23R-FS-L				
COMPONENTS / COMPOSANTS / COMPONENTES				
COMP AMPS:		LIGHT WATTS:	4	
COND FAN AMPS:		CTRL AMPS:		
DEF HTR AMPS:		B/TMCE HTR AMPS:		
DOOR HTR AMPS:		MIN CIRCUIT IN AMPS:		
EVAP FAN AMPS:		MAX OVR. CURRENT PROTECTION AMPS:		

370-60297-00 REV.B 11/21/14

II. RECEIPT INSPECTION

II. a - RECEIPT INSPECTION

All Centerline products are factory tested for performance and are free from defects when shipped. The utmost care has been taken in crating this product to protect against damage in transit. All interior fittings have been carefully secured and the casters/legs are boxed and strapped inside to prevent damage. Door keys will be attached to electric cord with nylon strip.

You should carefully inspect your Centerline unit for damage upon delivery. If damage is detected, you should save all the crating materials and make note on the carrier's Bill of Lading describing this. A freight claim should be filed immediately. If damage is subsequently noted during or immediately after installation, contact the respective carrier and file a freight claim. Under no condition may a damaged unit be returned to Traulsen without first obtaining written permission (return authorization). You may contact Traulsen customer care at (800) 333-7447 and select option 2 to request a return.

III. INSTALLATION

III. a - LOCATION

Select a proper location for your Centerline unit, away from extreme heat and allow proper clearance for air circulation. Allow enough clearance between the unit and the side wall in order to make use of the door stay open feature at 110° (self-closing feature operates up to 90°). The door(s) must be able to open a minimum of 90° in order to make use of the maximum clear door width available.

III. b - PACKAGING

All Centerline units are shipped from the factory bolted to a sturdy wooden pallet and packaged in a durable hexacomb cardboard panels.

Most exterior stainless steel and aluminum surfaces have a protective vinyl covering to prevent scratching during manufacturing, shipping and installation. After the unit is installed in place of service, remove and discard the covering from all surfaces.

If possible, we suggest that the cabinet remain bolted to the pallet during all transportation to the point of final installation. To remove the wooden pallet, the bolts can then be removed with a 3/4" socket wrench. Avoid laying the unit on its front, side or back for removal of the pallet.

NOTE: DO NOT LAY THE UNIT ON ITS SIDE DURING TRANSPORTATION OR INSTALLATION.

III. INSTALLATION (continued)

III. c - INSTALLING LEGS OR CASTERS

A set of four (4) 4" high casters are supplied standard for all Centerline Reach-In units. These are shipped from the factory packed inside a cardboard box which is strapped inside the cabinet to the lower shelf.

⚠ WARNING THE CABINET MUST BE BLOCKED AND STABLE BEFORE INSTALLING LEGS OR CASTERS.

The "Stem" casters are installed by threading them firmly into the cabinet bottom at each corner (see figure 1). For leveling, turn the casters counterclockwise to raise it, clockwise to lower it. Level the unit from front to back as well as side to side in this manner. The caster bolts are tightened using a 1/2" socket wrench.

Legs & 6" casters are available in lieu of 4" casters as an optional accessory kit for the same models. These are shipped inside a separate cardboard box containing four (4) casters/legs.

To install the legs or casters, first raise and block the reach-in a minimum of 7" from the floor. For installing legs, thread the legs into the threaded holes on the bottom of the cabinet (see figure 2). Be certain that all legs are tightly secured. When the unit is set in its final position, it is important for proper operation that the unit be level. The legs are adjustable for this purpose; turn the bottom of the leg counterclockwise to raise it, clockwise to lower it. Level the unit from front to back as well as side to side in this manner.

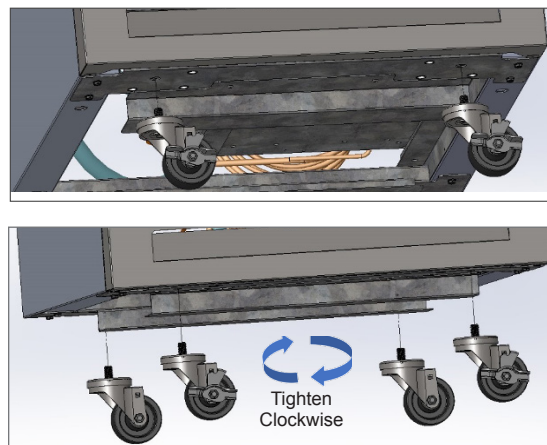

Fig. 1

III. INSTALLATION (continued)

III. c - INSTALLING LEGS OR CASTERS (cont'd)

Please note that Centerline units are not designed to be moved while on legs. If the unit requires moving, a pallet jack or fork- lift should be used to prevent damage.

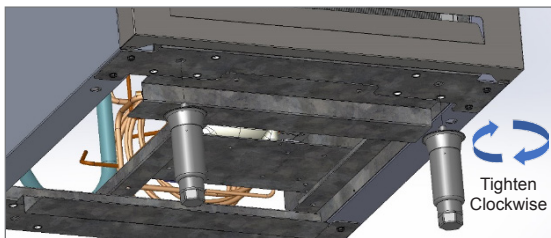
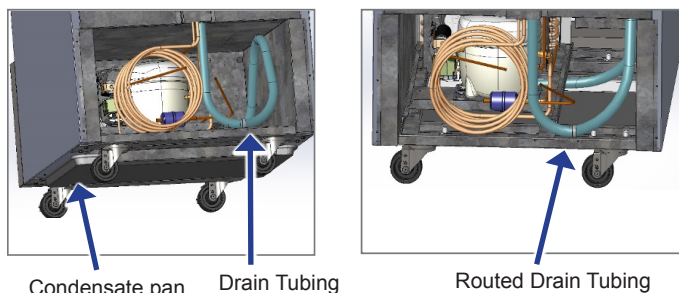

Fig. 2

III. d - INSTALLING DRAIN PAN

Centerline uprights are shipped with the condensate pan (full-size sheet pan) wrapped up and stored inside the unit.

Remove the condensate pan (full-size sheet pan) and slide it on the rails underneath the cabinet. Route the drain tubing through a bracket on the side wall to form a loop before dropping it into the pan. This will allow the water to drain into the pan.



Condensate pan sits on rails under the unit

Drain Tubing

Routed Drain Tubing

Fig. 3

NOTE: DRAIN PAN IS DESIGNED TO HOLD AND EVAPORATE DEFROST CONDENSATE FROM THE CABINET. HOWEVER, DUE TO OTHER OPERATIONS LIKE FLOOR CLEANING WITH WATER JETS/SPRAYS, IT MAY GET FULL AND OVERFLOW. IN THOSE CASES, DRAIN PAN CAN BE SLIDED OUT AND EMPTIED TO PREVENT SLIP HAZARD.

III. e - SHELVES

The unit is supplied with shelves and shelf clips to be installed on the pilasters. Check all shelf clips to assure they are firmly in place as they may have come loose during shipping. See section V.f for adjusting the shelves.

III. f - REMOVING DOORS & HARDWARE

In order to fit through narrow (less than 33.5") doorways, it may be necessary to remove the door(s), access panels and/or hinges. A Philip screwdriver may be required. First, unlock and open door to its open feature position about 110° and remove the screw holding each access panel (see figure 4 and figure 5).

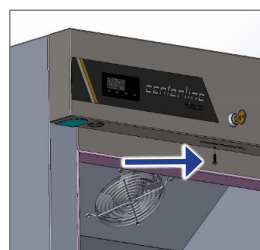
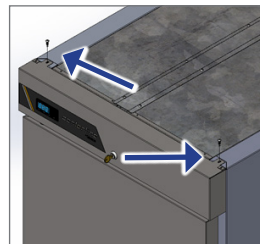

Remove Screws

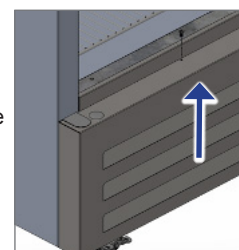
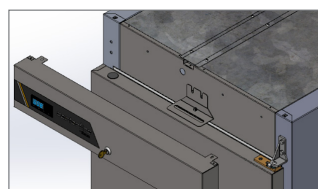
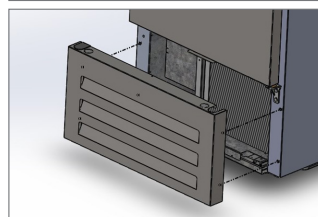

Fig. 4

After removing the screws, the top panel can be removed to access hinge hardware. Set the top panel on top of the unit as it will have wiring still attached to the control display. The bottom panel can be pulled off the pins to access hinge hardware. The bottom panel of full door configuration can be set aside. Half door configuration bottom panel may have wiring attached to the door switch. If needed, the wiring connectors can be disconnected so louver can be set aside.



Remove panel to access hinge hardware.



NOTE: Top/bottom louvers contain door switch for controlling interior lighting. Special care should be taken to prevent damaging the wiring during removal.

Fig. 5

After removing the panels, the hinge hardware can be accessed.

NOTE: ALWAYS SUPPORT THE DOOR WEIGHT OPPOSITE THE HINGE SIDE WHEN REMOVING TO PREVENT INJURY OR DAMAGE TO THE DOOR.

III. INSTALLATION (continued)

III. f - REMOVING DOORS & HARDWARE (cont'd)

Remove the top & bottom hinge brackets from the unit. Remember to support the door weight opposite the hinge side.

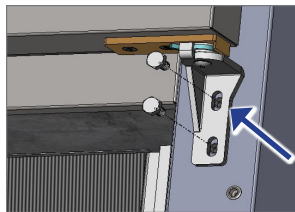

The bottom hinge plate bolts can be removed.

Fig. 6

To remove the door, two bolts on the bottom hinge brackets need to be removed. Then remove two bolts on the top hinge bracket. The door can then be lifted from the unit. Note: that hinge brackets are under spring tension. Carefully move the door just far enough to allow the bracket to unwind.

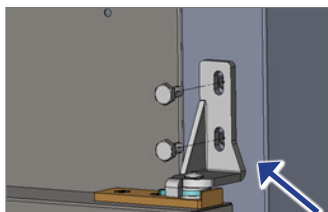

First, ensure the door weight opposite the hinge side is supported. The top hinge bracket bolts can be removed.

Fig. 7

To re-install the door, top and/or bottom louvers, and hinges, please reverse the appropriate sections of the preceding procedure.

III. g - DOOR REMOVAL FOR HALF DOOR UNITS

To begin, remove top/bottom panels, then open the door to its open feature position about 110°. For top door, remove two bolts on the top hinge bracket. The door can then be lifted up from the center hinge hardware. The plastic bushing will remain in the top door.

For bottom door: support the bottom door weight opposite the hinge side so minimum movement occurs when the bolts from the lower hinge plate are removed. Remove two bolts on the bottom hinge bracket. The door can then be moved down from the center hinge hardware. The plastic bushing will remain in the bottom door. Once top/bottom doors removed, two screws can then be removed on the center hinge.

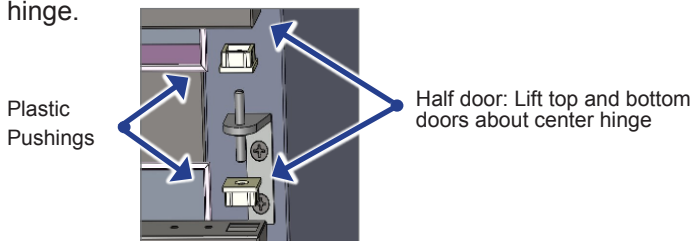

Half door: Lift top and bottom doors about center hinge

Fig. 8

Note that hinge brackets are under spring tension. Carefully move the door just far enough to allow the bracket to unwind.

II. h - CORD & PLUG

All Centerline reach-in models are supplied with a cord & plug attached. It is shipped coiled and secured by a nylon strip to the back of the cabinet near condensing unit area. For your safety and protection, all units supplied with a cord and plug include a special three-prong grounding plug on the service cord. Select only a dedicated electrical outlet with grounding plug for power source.

NOTE: DO NOT UNDER ANY CIRCUMSTANCES CUT OR REMOVE THE ROUND GROUNDING PRONG FROM THE PLUG OR USE AN EXTENSION CORD.

III. i - POWER SUPPLY

The supply voltage should be checked prior to connection to be certain that proper voltage for the cabinet wiring is available (refer to the serial tag to determine correct unit voltage). Make connections in accordance with local electrical codes. Use qualified electricians.

Use of a separate, dedicated circuit is required. Size wiring to handle indicated load and provide necessary over current protector in circuit (see amperage requirements on the unit's serial tag).

III. j - WIRING DIAGRAM

Refer to the wiring diagram located on the exterior back of the cabinet for any service work performed on the unit. Should you require one, please contact Traulsen Service at (800) 825-8220, and provide the model and serial number of the unit involved.

III. k - INSTALLING OPTIONAL INTERIOR KITS

In addition to their standard interiors, Centerline models also offer the option for additional shelves or tray slides. If ordered, these are shipped as kits along with the unit, packaged in a separate cardboard box which contains all the necessary parts and hardware for on-site installation.

To install additional shelves, install the included pins on the pre-cut holes where required. Secure the shelves to the pins using nylon tie-wraps.

Installation of optional tray slides varies with each cabinet, and with each type of tray slide ordered. To install optional tray slides, follow the directions packaged inside the kit carton.

IV. OPERATION (continued)

IV. OPERATION

Both refrigerators and freezers do not require manual defrosting. However, manual defrost option is available on the control, if required.

IV. a - OPERATION DISPLAY INDICATORS

During normal operation, the display shows either the temperature measured or one of the following indications:

dEF	Defrost in progress
oFF	Controller in stand-by
cL	Condenser clean warning
do	Door open alarm
E1	Probe T1 failure
E2	Probe T2 failure
E3	Probe T3 failure

IV. b - REFRIGERATORS

An off-cycle defrost happens every 6 hours for a maximum length of 30 minutes to melt any frost which may accumulate on the coil during the operation. During the Off-Cycle defrost, the compressor is off but the evaporator fans are turned on. The digital control will read “dEF” (see figure 10) during the defrost. When the temperature sensor affixed to the coil senses 44°F, the coil is fully defrosted and the compressor operation is resumed.

IV. c - FREEZERS

The coil requires a periodic defrosting for proper operation. This is accomplished by an automatic, time activated, temperature/time terminated, defrost program. The controller is preset at the factory for defrost cycles, approximately every 5 hours period.

The evaporator fan(s) cycle off with each door opening. The evaporator fan(s) will cycle on and off (during the compressor off cycle. During the compressor on cycle the evaporator fan(s) will run continuously. At the start of a freezer defrost cycle, both the compressor and evaporator fans are off. The digital control will read “dEF” (see figure 9).



Fig. 9

V. CARE AND MAINTENANCE

IV. c - FREEZERS (cont'd)

The electric heater (attached to the coil) is energized. When the temperature sensor affixed to the coil senses 44°F, the coil is fully defrosted and the compressor operation is resumed, defrost heaters are automatically turned off. The evaporator coil fans are delayed from starting at the termination of a defrost cycle. Fan operation is automatically resumed, after a short time or temp delay (whichever comes first). After completion, the total refrigeration system operation is then resumed. During defrost operation, heat is confined to the coil enclosure to prevent any significant rise in temperature within the food zone. The fan delay control function upon termination of a defrost cycle is two-fold. First, to prevent blowing warm air into the food storage area. Second, to prevent any condensation on the defrost coil from being blown into the food storage area.

IV. d - LIGHT SWITCHES

All Centerline models include a door switch mounted in the top, bottom, or both louvers depending on door configuration, which automatically activates the interior light when the door is opened. When the door is closed, the lights are automatically turned off.

In addition, on glass door models, lights are always illuminated whether the doors are open or not. It is possible to change this light feature to act only when door is open similar to solid doors if required. Please refer control section to change light function or contact Centerline Service department for step by step instructions.

V. CARE & MAINTENANCE

⚠ WARNING DISCONNECT ELECTRICAL POWER SUPPLY BEFORE CLEANING ANY PARTS OF THE UNIT.

V. a - CLEANING THE CONDENSER

The most important thing you can do to ensure a long, reliable service life for your Centerline is to regularly clean the condenser coil.

The condensing unit requires regularly scheduled cleaning to keep the finned condenser clean of lint and dust accumulation. Keeping the condenser clean allows the cabinet to operate more efficiently and use less energy. To clean the condenser, first disconnect electrical power to the cabinet.

V. CARE AND MAINTENANCE (continued)

V. a - CLEANING THE CONDENSER (cont'd)

Next, remove the front lower louver panel by removing the single screw from inside the door opening and gently pulling it towards front (refer to previous figures 4 and 5).

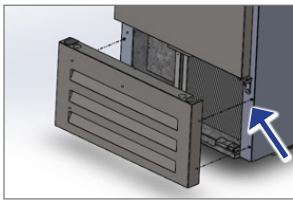

Remove single screw (seen in figure 4 and 5) and pull lower panel off to clean the condenser coil.

Fig. 10

NOTE: DOOR SWITCH WIRING MAY BE PRESENT AND ATTACHED TO THE LOUVER.

Vacuum or brush any dirt, lint or dust from the finned condenser coil, the compressor and other cooling system parts. If significant dirt is clogging the condenser fins, use compressed air to blow this clear. Care should be taken not to bend any of the condenser fins, as this will reduce performance and compressor life. Reverse the process to install louver assembly back in place.

V. b - HINGE REPLACEMENT

To replace the hinge, the upper and lower panels need to be removed from the face of the unit. The hinges can be removed as described in section III.f for door installation. Refer to section III.f for instructions to remove, install, and adjust torque on doors when replacing a hinge. Please refer service manual or contact service support for detailed instructions on hinge replacement

V. c - REPLACING THE GASKETS

To replace the gasket, grasp it firmly by one corner and pull it out. Before attempting to install a new gasket, both the unit and gasket must be at room temperature. Insert the four corners first by using a rubber mallet (or hammer with a block of wood). After the corners are properly inserted, work your way towards the center from both ends by gently hitting with a mallet until the gasket is completely seated in place (see figure 11 for proper gasket placement).

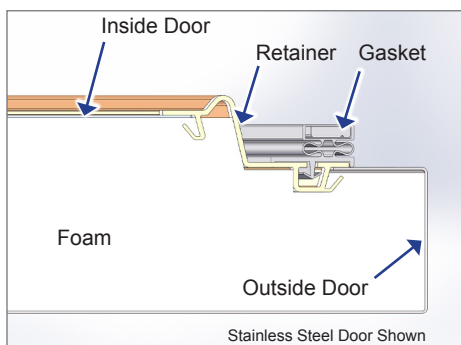

Fig. 11

V. d - CLEANING THE EXTERIOR

Exterior anodized aluminum should be cleaned with warm water, mild soap and a soft cloth. Apply with a dampened cloth and wipe in the direction of the metal grain.

Avoid the use of strong detergents and gritty, abrasive cleaners as they may tend to mar and scratch the surface. Do NOT use cleaners containing chlorine, this may promote corrosion of the stainless-steel door.

Care should also be taken to avoid splashing the unit with water, containing chlorinated cleansers, when mopping the floor around the unit.

For stubborn odor spills, use baking soda and water (mixed to a 1 TBSP baking soda to 1-pint water ratio).

V. e - CLEANING THE INTERIOR

For cleaning the interior, use baking soda with warm water, and a soft cloth. Apply with a dampened cloth and wipe in the direction of the metal grain. Use on breaker strips as well as door and drawer gaskets.

V. f - ADJUSTING THE SHELVES

Shelves and pins are shipped with the unit. First, select the desired location and remove the white plastic covers in the interior back and/or interior sides by rotating them. Install pins in the new desired location (turn clockwise to tighten). Make sure the pins are securely tightened. Slide the shelf on the pins as shown below & secure it to the pins using nylon tie-wraps. Replace the white plastic covers in the open holes from where the pins were removed.

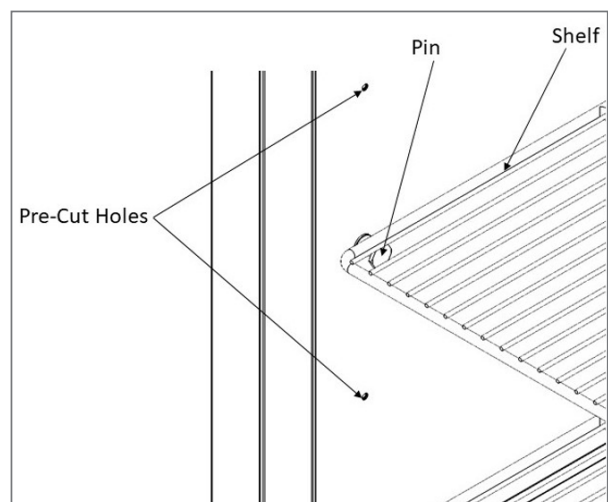

Fig. 12

VI. CONTROL BASICS

Your new Centerline Refrigerator or Freezer is equipped with a digital control, which precisely regulates operation. It is supplied from the factory completely ready for use.



VI. a - INFORMATION MENU

The information available in this menu is:

t1	Instant probe 1 temperature
t2*	Instant probe 2 temperature
cnd**	Compressor working weeks

* displayed only if enabled (see Configuration Parameters)

** displayed only if ACC > 0

Access to menu and information displayed:

- Press and immediately release button **i**.
- With button **▼** or **▲** select the data to be displayed.
- Press button **i** to display value.
- To exit from the menu, press button **x** or wait for 10 seconds.

Initiate Stand-By:

Keeping the button **⏻** pressed for 3 seconds allows the controller to be put on a standby or output control to be resumed (with **SB=YES** only).

Locking the Keypad:

The keypad lock avoids undesired, potentially dangerous operations, which might be attempted when the controller is operating in a public place. In the INFO menu, set parameter **LOC = YES** to inhibit all functions of the buttons. To resume normal operation of keypad, adjust setting so that **LOC = NO**.

VI. b - ADJUSTING CABINET SETPOINT

Setpoint display and modification:

- Press button **i** for at least a half second to display the setpoint value.
- While keeping the **i** button pressed, use button **▼** or **▲** to set the desired value (adjustment is within the minimum **SPL** and the maximum **SPH** limit).
- When button **i** is released, the new value is stored.

VI. c - INITIATING A DEFROST

Automatic defrost:

Defrost starts automatically as soon as the time set with parameter **DFT** has elapsed.

- Timed defrost: With **DFM = TIM** defrosts take place at regular intervals when the timer reaches the value of **DFT**. For example, with **DFM = TIM** and **DFT = 36**, a defrost will take place every 6 hours.
- Optimized defrost: With **DFM = FRO** the timer is only increased when the conditions occur for frost to form on the evaporator, until the time set with parameter **DFT** is matched. If the evaporator works at 0°F, defrost frequency depends on the thermal load and climatic conditions. With setpoints much lower than 0°F, defrost frequency mainly depends on the refrigerator operating time.
- Defrost time count backup: At the power-up, if **DFB = YES**, the defrost timer resumes the time count from where it was left off before the power interruption. Vice versa, with **DFB = NO**, the time count re-starts from 0. In stand-by, the accumulated time count is frozen.

VI. CONTROL BASICS (continued)

VI. c - INITIATING A DEFROST (cont'd)

Manual or remote defrost start:

It's possible to manually start a defrost, by pressing button  for 2 seconds.

Defrost type. Once defrost has started, Compressor and Defrost outputs are controlled according to parameter

DTY. If **FID** = YES, the evaporator fans are active during defrost.

Defrost termination. The actual defrost duration is influenced by a series of parameters.

- Time termination: **T2** = NO and **T3** different from 2EU: the evaporator temperature is not monitored and defrost will last as long as time **DTO**.
- Temperature monitoring of one evaporator: **T2** = YES and **T3** different from 2EU. In this case, if the sensor **T2** measures the temperature **DLI** before the time **DTO** elapses, defrost will be terminated in advance.











Resuming thermostatic cycle:

When defrost is over, if **DRN** is greater than 0, all outputs will remain off for **DRN** minutes, in order for the ice to melt completely and the resulting water to drain. Moreover, if probe **T2** is active (**T2** = YES), the fans will re-start when the evaporator gets to a temperature lower than **FDD**; Vice versa, if probe **T2** is not active (**T2** = NO) or after defrost has come to an end, such condition does not occur by end of the time **FTO**, after **FTO** minutes have elapsed the fans will be switched on anyway.

Caution: if **DFM** = NON or **C-H** = HEA all defrost functions are inhibited; if **DFT** = 0, automatic defrost functions are excluded.

VI. d - CONFIGURATION PARAMETERS

Parameter Configuration:

- To get access to the parameter configuration menu, press button  and  for 5 seconds.
- With button  or  select the parameter to be modified.
- Press button  to display the value.
- By keeping button  pressed, use button  or  to set the desired value.
- When button  is released, the newly programmed value is stored and the following parameter is displayed.
- To exit from the setup, press button  or wait for 30 seconds.

VI. e - TECHNICAL DATA

Power supply

TRL-002...W 100-240Vac ±10%, 50/60Hz, 3W

Relay output max loads (240Vac)

	TRL-002..S/T..-	TRL-002..Q/R..-
Compressor	16A resistive 12 FLA 48 RLA	12A resistive 12 FLA 48 RLA
Evap. Fan	16A resistive 4 FLA 12 RLA	8A resistive 4 FLA 12 RLA
Defrost	16A resistive 4 FLA 12 RLA	16A resistive 4 FLA 12 RLA
Auxiliary loads 1	7A resistive	7A resistive
Auxiliary loads 2	7A resistive	7A resistive

Input

NTC 10KΩ@25°C LAE Part No. SN4...

Measurement Range

<0.5 within the measurement range

Operating Conditions

-10... +50°C; 15%...80% r.H.

CE (Approvals and Reference Norms)

EN60730-1; EN60730-2-9; EN55022 (Class B); EN50082-1

VI. CONTROL BASICS (continued)

PAR	RANGE	DESCRIPTION
SPL	-58..SPH	Minimum limit for SP setting.
SPH	SPL...180°	Maximum limit for SP setting.
SP	SPL... SPH	Setpoint (value to be maintained in the room).
C-H	REF; HEA	Refrigerating (REF) or Heating (HEA) control mode.
HY0	1...10°	Thermostat OFF -> ON differential.
HY1	0...10°	Thermostat ON -> OFF differential.
CRT	0...30min	Compressor rest time. The output is switched on again after CRT minutes have elapsed since the previous switchover. We recommend to set CRT=03 with HY0<2.0°.
CT1	0...30min	Compressor/Heater output run when probe T1 is faulty. With CT1=0 the output will always remain OFF.
CT2	0...30min	Compressor/Heater output stop when probe T1 is faulty. With CT2=0 and CT1>0 the output will always be ON. Example: CT1=4, CT2= 6: In case of probe T1 failure, the compressor will cycle 4 minutes ON and 6 minutes OFF.
DFM	NON; TIM; FRO CRN	Defrost start mode NON : defrost function is disabled (the following parameter will be FCM). TIM : regular time defrost. FRO : the defrost time count is only increased when the conditions occur for frost to form on the evaporator (optimized time increase). CRN : defrost is based off of compressor run time (time is based off of DAT).
DFT	0...250	Time interval among defrosts in x10 minutes. When this time has elapsed since the last defrost, a new defrost cycle is started. Each number is multiplied by 10 minutes. 0-250 indicates 0-2500 minutes.
DAT	0...100 hours	Frost accumulation timeout.
DFB	NO/YES	Defrost timer backup. With DFB=YES, after a power interruption, the timer resumes the count from where it was left off with ±30 min. approximation. With DFB=NO, after a power interruption, the defrost timer will re-start to count from zero.
DLI	-58...180°	Defrost end temperature.
DMD	0...30min	Minimum defrost duration.
DTO	1...120min	Maximum defrost duration.
DTY	OFF; ELE; GAS	Defrost type OFF: off cycle defrost (Compressor and Heater OFF). ELE: electric defrost (Compressor OFF and Heater ON). GAS: hot gas defrost (Compressor and Heater ON).
DSO	OFF; LO; HI	Defrost start optimization OFF : no optimization. LO : defrost waits until the compressor cut-out. HI : defrost waits until the compressor cut-in.
SOD	0...30 min	Start optimization delay.
DPD	0...240sec	Evaporator pump down. At the beginning of defrost, defrost outputs (determined by DTY) are OFF for DPD seconds.
DRN	0...30min	Pause after defrost (evaporator drain down time).

VI. CONTROL BASICS (continued)

PAR	RANGE	DESCRIPTION
DDM	RT; LT; SP; DEF	Defrost display mode. During defrost the display will show: RT : the real temperature; LT : the last temperature before defrost; SP : the current setpoint value; DEF : "dEF".
DDY	0...60min	Display delay. The display shows the information selected with parameter DDM during defrost and for DDY minutes after defrost termination.
FID	NO/YES	Fans active during defrost.
FDD	-58...180°	Evaporator fan re-start temperature after defrost.
FTO	0...120min	Maximum evaporator fan stop after defrost.
FCM	NON; TMP; TIM	Fan mode during thermostatic control. NON : The fans remain ON all the time; TMP : Temperature-based control. The fans are ON when the compressor is ON. When the compressor is turned OFF, the fans remain ON as long as the temperature difference $T_e - T_a$ is greater than FDT. The fans are turned ON again with FDH differential. (T_e = Evaporator temperature, T_a = Air temperature); TIM : Timed-based control. The fans are ON when the compressor is ON. When the compressor is OFF, the fans switch ON and OFF according to parameters FT1, FT2, FT3
FDT	-12...0°	Evaporator-Air temperature difference for the fans to turn OFF after the compressor has stopped.
FDH	1...12°	Temperature differential for fan re-start. Example: FDT = -1, FDH=3. In this case, after the compressor has stopped, the fans are OFF when $T_e > T_a - 1$ (FDT), whereas the fans are ON when $T_e < T_a - 4$ (FDT-FDH).
FT1	0...180sec	Fan stop delay after compressor/heater stop. See Fig. 2
FT2	0...180	Timed fan stop in x10 seconds. With FT2=0 the fans remain on all the time.
FT3	0...180	Timed fan run in x10 seconds. With FT3=0, and FT2 > 0, the fans remain off all the time.
ATM	NON; ABS; REL	Alarm threshold management. NON : all temperature alarms are inhibited (the following parameter will be ACC). ABS : the values programmed in ALA and AHA represent the real alarm thresholds. REL : the alarm threshold is obtained by the sum of setpoint, thermostat differential and ALR/AHR.
ALA	-58... 180°	Low temperature alarm threshold.
AHA	-58... 180°	High temperature alarm threshold.
ALR	-12... 0°	Low temperature alarm differential. With ALR=0 the low temperature alarm is excluded.
AHR	0... 12°	High temperature alarm differential. With AHR=0 the high temperature alarm is excluded.
ATI	T1; T2; T3	Probe used for temperature alarm detection.
ATD	0... 120 min	Delay before alarm temperature warning.
ACC	0...52 weeks	Condenser periodic cleaning. When the compressor operation time, expressed in weeks, matches the ACC value programmed, "CL" flashes in the display. With ACC=0 the condenser cleaning warning is disabled and CND disappears from Info Menu.
IISM	NON; MAN; ECO; DI	Switchover mode to second parameter set NON : inhibition to use the second parameter group (the following parameter will be SB). MAN : button switches the two parameter groups over. ECO : automatic switchover to the second parameter group, when ECO conditions are detected. DI : switchover to the second parameter group when DIx input is on.
IISL	-58... IISH	Minimum limit for IISP setting.
IISH	IISL... 180°	Maximum limit for IISP setting.
IISP	IISL... IISH	Setpoint in mode 2.
IIHO	1... 10°	Thermostat OFF->ON differential in mode 2.

VI. CONTROL BASICS (continued)

PAR	RANGE	DESCRIPTION
IIH1	0... 10°	Thermostat ON->OFF differential in mode 2.
IIDF	0...250	Time interval among defrosts in mode 2 in x10 minutes.
IIFC	NON; TMP; TIM	Fan control in mode 2. See FCM.
ECS	1...5	Controller sensitivity for the automatic switchover from Group I to Group II (1=minimum, 5=maximum).
ECS	1...5	Controller sensitivity for the automatic switchover.
EPT	0...240 min	Eco pull-down time. Only with IISM=ECO. Group I parameters are used in regulation for at least EPT minutes. See Fig.3
SB	NO/YES	Stand-by button enabling.
DSM	NON; ALR; STP	Door switch input mode: NON : door switch inhibited ALR : when DIx=DOR and the digital input is on, an alarm is generated after ADO minutes STP : when DIx=DOR and the digital input is on, in addition to the alarm, the fans are immediately stopped and the compressor is stopped after CSD minutes.
DAD	0...30 min	Delay before door open alarm warning.
CSD	0...30 min	Compressor/heater stop delay after door has been opened.
D10	NON; DOR; ALR; IISM; RDS	DI1 digital input operation NON : digital input 1 not active. DOR : door input. ALR : when the input is on, an alarm is generated (if AHM=STP, the compressor is stopped and the defrosts are suspended). IISM : when the input is on, the controller will use group 2 parameters. RDS : when the input is on, a defrost is started (remote control).
D1A	OPN; CLS.	DI1 digital input activation. OPN : on open CLS : on close
D20	See D10	DI2 digital input operation. See D10.
D2A	OPN; CLS.	DI2 digital input activation. OPN : on open CLS : on close
PSL	-58...158	Minimum setpoint adjusted via potentiometer.
PSR	0...15	Range of setpoint adjusted via potentiometer.
LSM	NON; MAN; ECO; DI1; DI2; DI3.	Light control mode NON : light output not controlled. MAN : light output controlled through button (if OAx=LGT). ECO : lights activated/deactivated following the ECO state. DIx : lights activated/deactivated following the DIx state.
LSA	OPN; CLS	Light activation (only with LSM=ECO or LSM=DIx). OPN : lights on with DIx open or ECO mode deactivated. CLS : lights on with DIx closed or ECO mode activated.
OT1	0...600 sec	Activation time of OA1
OT2	0...600 sec	Pause between OA1 activation

VI. CONTROL BASICS (continued)

PAR	RANGE	DESCRIPTION
OA1	NON; LGT; 0-1; 2CU; 2EU; ALO; ALC	AUX 1 output operation NON : output disabled (always off). LGT : output enabled for light control. 0-1 : the relay contacts follow the on/standby state of controller. 2CU : output programmed for the control of an auxiliary compressor. 2EU : output enabled for the control of the electrical defrost of a second evaporator. ALO : contacts open when an alarm condition occurs. ALC : contacts make when an alarm condition occurs.
2CD	0...120 sec	Auxiliary compressor start delay. If OAx=2CU the auxiliary output is switched on with a delay of 2CD seconds after the main compressor has cut-in. Both compressors are turned off at the same time.
OS1	-12.5..12.5°	Probe T1 offset.
T2	NO/YES	Probe T2 enabling (evaporator).
OS2	-12.5..12.5°	Probe T2 offset.
T3	NON; DSP; CND; 2EU	Auxiliary probe T3 operation NON : probe T3 not fitted. DSP : temperature T3 to be displayed. CND : condenser temperature measurement. 2EU : second evaporator temperature measurement.
OS3	-12.5..12.5°	Probe 3 offset.
AHM	NON; ALR; STP;	Operation in case of high condenser alarm NON : high condenser alarm inhibited. ALR : in case of alarm, "HC" flashes in the display and the buzzer is switched on. STP : in addition to the alarm symbols displayed, the compressor is stopped and defrosts are suspended.
AHT	-50...110°	Condensation temperature alarm (referred to T3 probe).
TLD	1...30 min	Delay for minimum temperature (TLO) and maximum temperature (THI) logging.
TDS	T1; 1-2; T3	Selects the temperature probe to be displayed. T1 : probe T1 1-2 : the AVG-weighted average between T1 and T2 T3 : probe T3
AVG	0...100%	The relative weight of T2 on T1 (if TDS = 1-2) Example 1: T1 = -5°, T2 = -20°, AVG = 100%. The displayed temperature will be -20° (T1 has no effect) Example 2: T1 = -5°, T2 = -20°, AVG = 60%. The displayed temperature will be -14.
SCL	1°C; 2°C; °F	Readout scale. 1°C : measuring range -50...110°C (0.1°C resolution within -9.9 ÷ 19.9°C interval, 1°C outside) 2°C : measuring range -50 ... 110°C °F : measuring range -55 ... 180°F
SIM	0...100	Display slowdown.
ADR	1...255	TRL-002 address for PC communication.
NPR	0...1	Setup programmed.
STT	0...255	Setup traceability.

VI. CONTROL BASICS (continued)

VI. f - COMPONENTS AND WIRING DIAGRAM



Indications:

 Thermostat output

 Fan output

 Defrost output

 Activation of 2nd parameter set

 Alarm

 Manual activation / Increase button

 Exit / Stand-by button

Control Wiring Diagram:

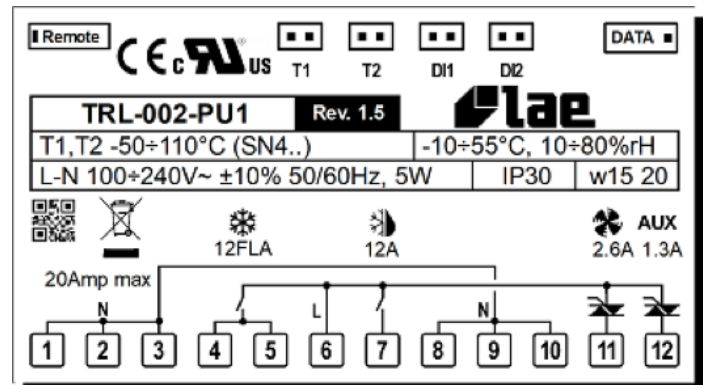

VII. TROUBLESHOOTING GUIDE

VII. a -TROUBLESHOOTING GUIDE

FIND YOUR PROBLEM HERE	REMEDY
1. Condensing unit fails to start.	<ul style="list-style-type: none"> a. Check if cord & plug has been disconnected. b. Check control temperature setting.
2. Condensing unit operates for prolonged periods or continuously.	<ul style="list-style-type: none"> a. Are doors closing properly? b. Dirty condenser or filter. Clean properly. c. Evaporator coil iced. Needs to defrost. See instructions for setting a manual defrost cycle on section VI.c.
3. Food compartment is too warm.	<ul style="list-style-type: none"> a. Check door(s) and gasket(s) for proper seal b. Perhaps a large quantity of warm food has recently been added or the door was kept open for a long period of time, in both cases, allow adequate time for the cabinet to recover its normal operating temperature. c. Control setting too high, readjust per instructions on section VI.b. d. Check that condensing coil is clean.
4. Food compartment is too cold.	<ul style="list-style-type: none"> a. Perhaps a large quantity of very cold or frozen food has recently been added. Allow adequate time for the cabinet to recover its normal operating temperature. b. Adjust the control to a warmer setting, see section VI.b.
5. Condensation on the exterior surface.	<ul style="list-style-type: none"> a. Check door alignment and gaskets for proper seal. b. Condensation on the exterior surface of the unit is perfectly normal during periods of high humidity.
6. Compressor hums but does not start.	<ul style="list-style-type: none"> a. Call for service.
7. No power to unit	<ul style="list-style-type: none"> a. Check if cord & plug has been disconnected. b. Check power supply breaker.

VIII. SERVICE/WARRANTY INFORMATION

VIII. a - SERVICE INFORMATION

Before calling for service, please check the following:

- Is the electrical cord plugged in?
- Is the fuse OK or circuit breaker on?
- Is the condenser coil clean?
- Is the power switch on?

If after checking the above items and the unit is still not operating properly, please contact an authorized Centerline by Traulsen service agent:

4401 Blue Mound Road Fort Worth, TX 76106
(800) 825-8220.

Centerline by Traulsen reserves the right to change specifications or discontinue models without notice.

VIII. b - SPARE PARTS INFORMATION

To purchase replacement parts or to speak to service support for Centerline by Traulsen units please contact our Ft. Worth facility by phone at 800-825-8220 or fax to 817-740-6748 (parts) or 817-740-6757 (service).

Note: When calling for spare parts or service support, please make sure you have model and serial number of unit available.

Model Number
 Serial Number

MODEL NUMBER		102120041F-010	
S/N		102120041F	
REFRIGERANT / REFRIGERANTS / REFRIGERANT			
R134A (lb)	0.120	R404A (lb)	0.120
R134A (kg)	0.054	R404A (kg)	0.054
R134A (oz)	1.72	R404A (oz)	1.72
R134A (g)	172	R404A (g)	172
R134A (oz)	1.72	R404A (oz)	1.72
R134A (g)	172	R404A (g)	172
REPAIR POWER (WATT) - FOR WINDON USE ONLY			
Symbol 1	Symbol 2	Symbol 3	Symbol 4
(A/C Safety / Other 1)	(A/C Gas / Other 2)	(A/C Oil / Other 3)	(Other 4)
Symbol 5	Symbol 6	Symbol 7	Symbol 8
(Other 5)	(Other 6)	(Other 7)	(Compressor Oil Code / Other 8)
Component Number Methods			
COMPONENTS / COMPONENTS / COMPONENTS			
COMP AMP	COMP FAN AMP	COMP FAN AMP	COMP FAN AMP
COND FAN AMP	COND FAN AMP	COND FAN AMP	COND FAN AMP
COND FAN AMP	COND FAN AMP	COND FAN AMP	COND FAN AMP
COND FAN AMP	COND FAN AMP	COND FAN AMP	COND FAN AMP
COND FAN AMP	COND FAN AMP	COND FAN AMP	COND FAN AMP

VIII. c - WARRANTY REGISTRATION:

The warranties for your new Traulsen unit may be registered with us by by completing warranty information online, via our website www.CenterlineFoodEquipment.com. Click on the Product Registration text at the footer of the home page. You may also register your product by calling us directly at 800-825-8220.

VIII. SERVICE/WARRANTY INFORMATION (continued)

VIII. d - WARRANTY STATEMENT:



TRAULSEN EQUIPMENT WARRANTY



U.S. Domestic Warranty

For sales of Traulsen refrigeration equipment ("Equipment") within the United States, Traulsen warrants to the original purchaser of the Equipment ("Purchaser") that Traulsen will convey the Equipment free and clear of all liens, security interests, and encumbrances created by, through or under Traulsen. Traulsen further warrants that for a period of three (3) years from the later of either (a) the date of delivery to the common carrier or (b) the date of installation (the "Domestic Warranty Period") but in no event, shall the Domestic Warranty Period commence later than 3 months from the date of delivery to the common carrier unless otherwise agreed upon by the parties in writing, under normal use and given proper installation and maintenance as determined by Traulsen, the Equipment: (a) will conform to the specifications as provided by Traulsen ("Specifications") and (b) will be free from substantial defects in material and workmanship.

The warranty period for compressors shall extend for an additional two (2) years beyond the Domestic Warranty Period. In the case of a nonconforming compressor, Traulsen shall provide a replacement compressor; however, all installation, recharging, and repair costs shall be the responsibility of Purchaser. In the case of a nonconforming part, Purchaser must return the part to Traulsen within 30 days from the date of repair. Failure to return a claimed defective part to Traulsen within the 30 days will waive the right to the warranty claim.

Additionally, Traulsen provides a lifetime warranty on the housing of cam-lift hinges and the workflow handles. In the case of a non-conforming housing for cam-lift hinge or workflow handle, Traulsen shall provide a replacement part; however, Purchaser shall be responsible for any other replacement costs, including but not limited to installation and labor.

The Domestic Warranty does not apply to: (a) consumable components or ordinary wear items; (b) components that are removable without the use of tools including but not limited to gaskets, shelf pins, and light bulbs; (c) use of the Equipment components or parts not supplied by Traulsen or specified by Traulsen in the Operator's Manual as set forth on Traulsen's website; or (d) damage resulting from fire, water, burglary, accident, abuse, misuse, transit, acts of God, terrorism, power surges, improper installation, or repairs or installation by unauthorized third parties. Additionally, the Equipment is intended only for commercial use and should not be used by consumers or households or in any non-commercial application. This Domestic Warranty does not apply to, and shall not cover, any Equipment that is installed or used in any way in any residential or non-commercial application. No warranties, express or implied, are provided to any residential, consumer or non-commercial purchaser or owner of the Equipment.

For Traulsen units purchased for use with a condenser provided by a third-party, this standard warranty will apply only to those components contained within the unit to the point of connection of the refrigeration lines leading to the third-party condenser.

In the event of a breach of the warranties set forth above (the "Domestic Warranty"), Traulsen will, at Traulsen's option and as Purchaser's sole remedy, repair or replace, including labor costs, any nonconforming Equipment, provided that (a) during the Warranty Period Traulsen is promptly notified in writing upon discovery of the nonconformance with a detailed explanation of any alleged deficiencies; (b) Traulsen is given a reasonable opportunity to investigate all claims; and (c) Traulsen's examination of any alleged defective part confirms such alleged deficiencies and that the deficiencies were not caused by misuse, neglect, improper installation, unauthorized alteration or repair or improper testing. Traulsen reserves the right to, at its request, require Purchaser shall ship the alleged defective part to Traulsen for inspection and confirmation of defect. No Equipment may be returned without Traulsen's approval.

Purchaser is solely responsible for determining if Equipment is fit for a particular purpose and suitable for Purchaser's application. Accordingly, and due to the nature and manner of Traulsen's Equipment, Traulsen is not responsible for the results or consequences of use, misuse, or application of its Equipment.

THIS DOMESTIC WARRANTY SETS FORTH THE EXTENT OF TRAULSEN'S LIABILITY FOR SALES WITHIN THE UNITED STATES. EXCEPT AS SET FORTH ABOVE, TRAULSEN MAKES NO WARRANTY OR REPRESENTATION OF ANY KIND, EXPRESS OR IMPLIED (INCLUDING NO WARRANTY OF MERCHANTABILITY OR FITNESS FOR ANY PARTICULAR PURPOSE). IN NO EVENT WILL TRAULSEN'S LIABILITY IN CONNECTION WITH THE AGREEMENT OR SALE OF THE EQUIPMENT EXCEED THE PURCHASE PRICE OF THE EQUIPMENT AS TO WHICH THE CLAIM IS MADE. IN NO EVENT SHALL TRAULSEN BE LIABLE FOR ANY LOSS OF USE, LOSS OF PRODUCT, LOSS OF PROFIT, OR ANY OTHER INDIRECT, INCIDENTAL, SPECIAL, OR CONSEQUENTIAL DAMAGES RESULTING FROM THIS WARRANTY EVEN IF TRAULSEN HAS BEEN NOTIFIED OF THE POSSIBILITY OF SUCH DAMAGES.



TRAULSEN
4401 BLUE MOUND RD.
PHONE 1 (800) 825-8220
Website: www.traulsen.com

FT. WORTH, TX 76106
FAX-MKTG. 1 (817) 624-4302



4401 Blue Mound Road Fort Worth, Texas 76106 (USA)

Phone: 800.825.8220 | Service Fax: 817.740.6757 | E-mail: service@traulsen.com | Website: centerlinefoodequipment.com

Form Number: TR36229 | Part Number: 375-60364-00 (Rev. C) | Revision Date: 09-21-22

Traulsen © All Rights Reserved

TITAN STAINLESS

CUSTOM FOODSERVICE FABRICATION

502 Usher Street · Pageland, SC · 704-243-8717 · www.titan-stainless.com



WORKTABLE WITH FLAT TOP AND OPEN BASE

TITAN STAINLESS worktables are made using all-welded heavy gauge stainless steel construction. Assembly is not required; however, equipment can be disassembled for convenience. All edges feature our standard nosing: 1-1/2" flange down with 1/2" return at 45°. Reinforcing channels are applied to the underside of the top and sealed with double-sided sound dampening tape. 1-5/8" diameter tubing is fitted into stainless steel leg sockets, which are welded to reinforcement below, preventing surface imperfections. Legs are removable, and furnished with adjustable stainless steel bullet feet. 1-5/8" diameter cross-rails are welded to the table legs. All welds are ground and polished to a smooth finish.



MODEL NUMBER SELECTION / INFORMATION

(Example #: 5SLC-30)

Worktables are available in standard lengths from 2'-0" to 12'-0", in 1-foot increments. Standard widths (front-to-back) are available in 24", 30", and 36". Units over 6'-0" long will be furnished with an additional set of legs.

- See **AutoQuotes™** for full list of model numbers and pricing, along with all additional accessories
- Custom sizes and configurations are available upon request

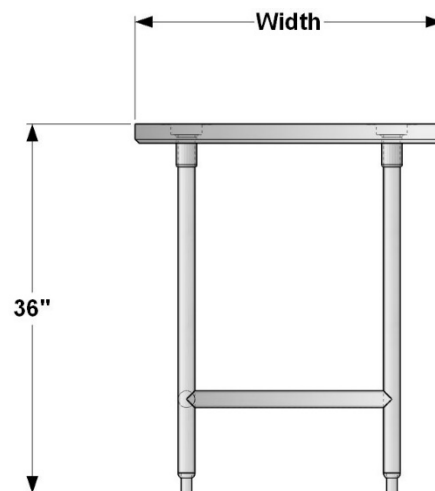
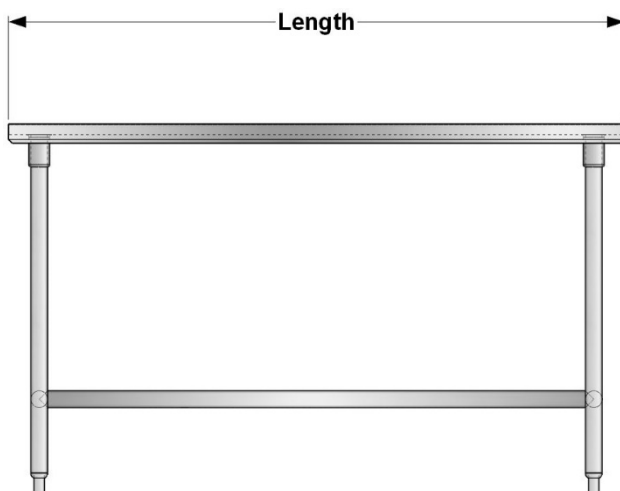

WARING COMMERCIAL

Automatic/Pour-over Coffee Brewers WCM70PAP

Unit Information
Warranty 2 Yr. Parts & 1 Yr. Labor
60Hz - 1660 Watts - 120 Volts
96 oz. Coffee Brewer for Airpot

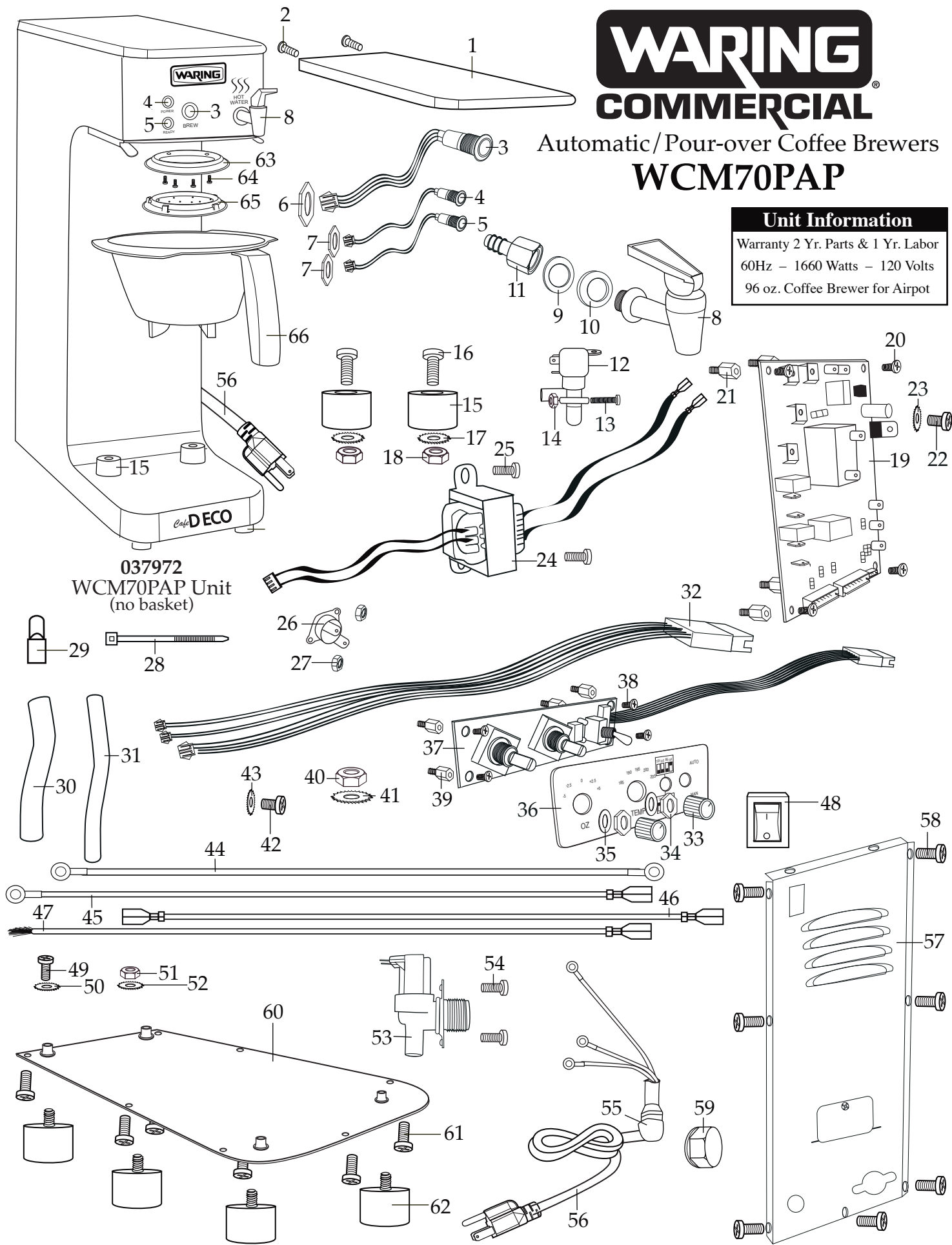

037972
WCM70PAP Unit
(no basket)

Illustration#	Part#	Description
1	037994	Top Plate
2	037166	Screw (2 required)
3	038005	Brew Light Assembly
4	038006	Red Power Light Assembly
5	038007	Green Read Light Assembly
6	038008	Hex Nut
7	016236	Hex Nut
8	037988	Tap (spigot)
9	037989	Rubber Washer
10	037990	Metal Washer
11	037991	Tap Hose Adapter
12	037996	Brew Solenoid
13	037997	Screw (2 required)
14	037171	Hex Nut (2 required)
15	038003	Rubber Stopper (2 required)
16	038004	Screw (2 required)
17	037175	Lock Washer (2 required)
18	037174	Hex Nut (2 required)
19	037987	PCB Board
20	038010	Plastic Screw (4 required)
21	038011	Plastic Connector (4 required)
22	037161	Screw (attached lead to PCB Board)
23	037158	Lock Washer (attached lead to PCB Board)
24	037708	Transformer
25	037166	Screw (2 required)
26	037153	Thermal Cut Off
27	037154	Hex Nut
28	013731	Wire Ties (10 required)

Illustration#	Part#	Description
29	019123	Large Crimp Connectors (2 required)
30	Large Hoses	
	037999	2" Hose
	038000	5.25" Hose
	038001	9.5" Hose
	038002	10.5" Hose
31	037998	7.5" Thin Hose
32	037992	Lead Tape with Black Sleeve
33	038013	Knob (2 required)
34	038015	Hex Nut (2 required)
35	038014	Washer (2 required)
36	038012	Temperature Board Cover
37	038016	Temperature Board
38	038010	Plastic Screw (4 required)
39	038011	Plastic Connector (4 required)
40	037174	Hex Nut (2 required)
41	037175	Lock Washer (2 required)
42	037161	Screw (lead to element 2 required)
43	037158	Lock Washer (lead to element 2 required)
44	Leads with 2 Ring Terminals	
	037973	6.75" Red Lead
	037974	6.75" Blue Lead
	037975	12.5" Yellow / Green Lead
45	Leads with 1 Regular and 1 Ring Terminal	
	037978	4.75" Red Lead
	037976	8.5" Yellow / Green Lead
	037979	8.75" Black Lead (2 required)
	037977	12.75" Blue Lead
46	Lead with 2 Regular Terminals	
	037984	12.25" Red Lead
	037982	17" Red Lead
	037983	17" Blue Lead
	037980	28.5" Red Lead
	037981	28.5" Blue Lead

Illustration#	Part#	Description
47		Lead with 1 Regular Terminal ONLY
	037985	20.25" Red Lead
	037986	20.25" Blue Lead
48	038017	Rocker Switch
49	037166	Screw (ground 2 required)
50	037158	Lock Washer (ground 2 required)
51	037171	Hex Nut (ground 2 required)
52	037158	Lock Washer (ground 2 required)
53	037165	Water Fill Solenoid
54	037166	Screw (2 required)
55	037172	Strain Relief
56	037173	Cord Set
57	037993	Back Plate
58	037166	Screw (9 required)
59	037705	Yellow Valve Cover
60	037995	Bottom Plate
61	037166	Screw (7 required)
62	037942	Foot (4 required)
63	038072	Spreader Holder
64	038076	Screw (4 required)
65	038044	Spreader
66	038018	Brew Basket



038020
Package of Filters

WARING
COMMERCIAL
TORRINGTON, CT 06790
AUTOMATIC COFFEE BREWER/
CAFETIÈRE COMMERCIALE À REMPLISSAGE AUTOMATIQUE
MODEL / MODÈLE: WCM70PAP
120VAC 60Hz 1660W
MADE IN CHINA / FABRIQUÉ EN CHINE
APPROVED FOR COMMERCIAL USE /
USAGE COMMERCIAL AUTORISÉ
CAUTION: DO NOT IMMERSE IN LIQUID /
ATTENTION: NE PAS PLONGER DANS L'EAU

Date Code Location → D/C: WWYY
D/C: WWYY
(week week year year)